



ชุดจำลองการควบคุมเครื่องกำเนิดไฟฟ้ากระแสสลับสามเฟส
เพื่อศึกษาคุณลักษณะของเครื่องกำเนิดไฟฟ้ากระแสสลับสามเฟส
Model Controlled of A.C. Three Phase Generator
for Characterization of A.C. Three Phase Generator

นายนิธวัฒน์ อากาศวิภาต
นายภาณุวัฒน์ ภูมิสุนทรธรรม
นายศรัณฐ์ ฉลาดยิ่ง

ปริญญานิพนธ์นี้เป็นส่วนหนึ่งของการศึกษาตามหลักสูตรปริญญาวิศวกรรมศาสตรบัณฑิต
สาขาวิชาวิศวกรรมไฟฟ้า
คณะวิศวกรรมศาสตร์ มหาวิทยาลัยเทคโนโลยีราชมงคลพระนคร
ปีการศึกษา 2556
ลิขสิทธิ์ของคณะวิศวกรรมศาสตร์ มหาวิทยาลัยเทคโนโลยีราชมงคลพระนคร

คณะวิศวกรรมศาสตร์
มหาวิทยาลัยเทคโนโลยีราชมงคลพระนคร
ใบรับรองปริญญาานิพนธ์

หัวข้อปริญญาานิพนธ์ ชุดจำลองการควบคุมเครื่องกำเนิดไฟฟ้ากระแสสลับสามเฟส
เพื่อศึกษาคุณลักษณะของเครื่องกำเนิดไฟฟ้ากระแสสลับสามเฟส
Thesis Title Model Controlled of A.C. Three Phase Generator for
Characterization of A.C. Three Phase Generator
ชื่อนักศึกษา นายนิธิวัฒน์ อากาศวิภาต
รหัสประจำตัว 055250403035-4
ชื่อนักศึกษา นายภาณุวัฒน์ ภูมิสุนทรธรรม
รหัสประจำตัว 055250403009-9
ชื่อนักศึกษา นายศรัณฐ์ ฉลาดยิ่ง
รหัสประจำตัว 055250403006-5
ปริญญา วิศวกรรมศาสตรบัณฑิต
สาขาวิชา วิศวกรรมไฟฟ้า
อาจารย์ที่ปรึกษาปริญญาานิพนธ์ ดร.นัฐโชติ รักไทยเจริญชีพ

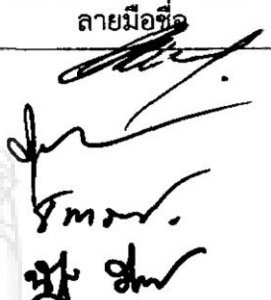
คณะกรรมการสอบปริญญาานิพนธ์		ลายมือชื่อ
อาจารย์ออดิศักดิ์	วิริยกรรม	
ผู้ช่วยศาสตราจารย์ศุภวุฒิ	เนตรโพธิ์แก้ว	
อาจารย์ธนารัตน์	ต้นมณีประเสริฐ	
ดร.นัฐโชติ	รักไทยเจริญชีพ	

วัน/เดือน/ปีที่สอบ 28 กุมภาพันธ์ 2556 เวลา 13.50 – 14.35 น.
สถานที่สอบณอาคารสาขาวิศวกรรมไฟฟ้าชั้น 2 (ห้อง 3201)

สาขาวิชาวิศวกรรมไฟฟ้ารับรองแล้ว



(ดร.ณัฐพงศ์ พันธนะ)

หัวหน้าสาขาวิชาวิศวกรรมไฟฟ้า
คณะวิศวกรรมศาสตร์

หัวข้อปริญญานิพนธ์ : ชุดจำลองการควบคุมเครื่องกำเนิดไฟฟ้ากระแสสลับสามเฟส
เพื่อศึกษาคุณลักษณะของเครื่องกำเนิดไฟฟ้ากระแสสลับสามเฟส
โดย : นายนิธิวัฒน์ อากาศวิภาต 055250403035-4
นายภาณุวัฒน์ ภูมิสุนทรธรรม 055250403009-9
นายศรัณัฐ ฉลาดยิ่ง 055250403006-5
อาจารย์ที่ปรึกษา : ดร.นัฐโชติ รักไทยเจริญชีพ
ภาควิชาและคณะ : วิศวกรรมไฟฟ้า
ปีการศึกษา : 2555

บทคัดย่อ

ปริญญานิพนธ์นี้ได้ทำการจำลองการควบคุมการทำงานของเครื่องกำเนิดไฟฟ้ากระแสสลับสามเฟส โดยเป็นการศึกษาและวิเคราะห์คุณลักษณะของเครื่องกำเนิดไฟฟ้าในสภาวะการทำงานต่าง ๆ โดยมีการจำลองรูปแบบการทำงานของเครื่องกำเนิดไฟฟ้าที่ใช้งานอยู่จริงตามสถานประกอบการ ที่มีการใช้เครื่องกำเนิดไฟฟ้าเป็นพลังงานสำรองจากแหล่งพลังงานหลักจากการไฟฟ้า โดยสามารถทดสอบการเริ่มเดินหรือการหยุดเดินเครื่องกำเนิดไฟฟ้าเพื่อตรวจสอบค่าพารามิเตอร์ต่างๆ ในขณะนั้น การจ่ายโหลดของเครื่องกำเนิดเพื่อตรวจสอบค่าพารามิเตอร์ในขณะที่จ่ายโหลด การขนานเครื่องกำเนิดไฟฟ้าเข้าสู่ระบบในกรณีฉุกเฉินเมื่อเกิดความผิดพลาดของระบบพลังงานหลักจากการไฟฟ้า การปลดเครื่องกำเนิดออกจากระบบเมื่อระบบพลังงานหลักกลับสู่สภาวะปกติ หรือการหยุดเครื่องกำเนิดแบบฉุกเฉินเมื่อเกิดความผิดพลาดในขณะทำงาน อีกทั้งยังมีระบบตรวจจับความผิดปกติจากชุดต้นกำลังของเครื่องกำเนิดไฟฟ้าซึ่งใช้เครื่องยนต์เป็นชุดต้นกำลัง

Project Report Title : Model Controlled of AC. Three Phase Generator
for Characterization of AC. Three Phase Generator
By : Mr. Nitiwat Arkardwipard 055250403035-4
Mr. Panuwat Poomsuntrontum 055250403009-9
Mr. Saran Chaladying 055250403006-5
Project Report Advisor : Dr. Nattachote Rugthaicharoencheep
Department of : Electrical Engineering
Academic Year : 2012

Abstract

This thesis is duplicated of the controlled of the AC. Three Phase Generator, with case study and analyze of the characteristic of generator in various operating conditions. By the model works of the actual use in establishment generator, this is using generator for backup electricity from main feeder. We have the functional testing of start or stop for check store the characteristics in different conditions at that time. Load distributing of generator for check store parameters. The parallelization of generator into the system in case of emergency, while the failure of the mains system. The degradation of generator off the system when main is back to normal or the emergency stops of generator, in case of accident during the operation.

กิตติกรรมประกาศ

การจัดทำวิทยานิพนธ์ฉบับนี้สำเร็จลุล่วงไปได้ด้วยดี เนื่องจากได้รับความช่วยเหลืออย่างดีจาก ดร.นัฐโชติ รักไทยเจริญชีพ อาจารย์ที่ปรึกษาวิทยานิพนธ์ ซึ่งได้กรุณาให้คำแนะนำและข้อคิดเห็นต่างๆ ที่เป็นประโยชน์ต่อการทำวิทยานิพนธ์มาโดยตลอด รวมไปถึง บริษัท คอมโพแม็ค จำกัด ที่ได้ให้การสนับสนุนอุปกรณ์และความรู้ทางด้านเทคนิคต่าง และขอกราบขอบพระคุณคณะกรรมการสอบวิทยานิพนธ์ทุกท่าน ที่ได้ให้คำแนะนำและข้อคิดเห็นที่เป็นประโยชน์

นายนิธิวัฒน์	อากาศวิภาต
นายภาณุวัฒน์	ภูมิสุนทรธรรม
นายศรัณฐ์	ฉลาตยิ่ง



สารบัญ

	หน้า
ใบรับรองปริญญาบัตรภาษาไทย	I
บทคัดย่อภาษาไทย	II
บทคัดย่อภาษาอังกฤษ	III
กิตติกรรมประกาศ	IV
สารบัญ	V
สารบัญตาราง	VII
สารบัญรูปภาพ	VIII
บทที่ 1 บทนำ	
1.1 ความเป็นมาของปัญหา	1
1.2 วัตถุประสงค์	2
1.3 ขอบเขตของการศึกษา	2
1.4 ขั้นตอนของการศึกษา	2
1.5 ประโยชน์ที่คาดว่าจะได้รับ	3
บทที่ 2 ทฤษฎีและงานวิจัยที่เกี่ยวข้อง	
2.1 เครื่องกำเนิดไฟฟ้ากระแสสลับสามเฟส	4
2.1.1 โครงสร้างของเครื่องกำเนิดไฟฟ้ากระแสสลับสามเฟส	5
2.1.2 ขดลวดของเครื่องกำเนิดไฟฟ้ากระแสสลับสามเฟส	7
2.1.3 คุณสมบัติของเครื่องกำเนิดไฟฟ้ากระแสสลับสามเฟส	11
2.1.4 แรงเคลื่อนไฟฟ้าเหนี่ยวนำของเครื่องกำเนิดไฟฟ้ากระแสสลับสามเฟส	13
2.1.5 การทำงานของเครื่องกำเนิดไฟฟ้ากระแสสลับสามเฟส	14
2.1.6 เวกเตอร์ไดอะแกรมของเครื่องกำเนิดไฟฟ้ากระแสสลับสามเฟส	
ขณะมีโหลด	18

สารบัญ (ต่อ)

	หน้า
2.2 การควบคุมเครื่องกำเนิดไฟฟ้ากระแสสลับสามเฟส	20
2.2.1 การควบคุมแรงดันไฟฟ้าด้วยมือ	21
2.2.2 การควบคุมแรงดันไฟฟ้าด้วยระบบอัตโนมัติ	21
2.2.3 โวลต์เตจเรกกูเรชั่น	22
2.2.4 การหาค่าของโวลต์เตจเรกกูเรชั่น	22
2.3 การขนานเครื่องกำเนิดไฟฟ้ากระแสสลับสามเฟสเข้าสู่ระบบ	25
บทที่ 3 การออกแบบและการประกอบสร้าง	
3.1 เงื่อนไขในการออกแบบชุดจำลองการควบคุมเครื่องกำเนิดไฟฟ้า	27
3.2. การออกแบบและประกอบสร้างเครื่องกำเนิดไฟฟ้า	28
3.3. การออกแบบและประกอบสร้างชุดควบคุมเครื่องกำเนิดไฟฟ้า	30
3.4. การออกแบบและประกอบสร้างชุดจำลองภาระทางไฟฟ้า	36
บทที่ 4 การทดลอง	
4.1 การทดลองที่ 1 เครื่องกำเนิดไฟฟ้าขณะไม่จ่ายโหลด	38
4.2 การทดลองที่ 2 เครื่องกำเนิดไฟฟ้าขณะจ่ายโหลด	41
4.3 การทดลองที่ 3 การขนานเครื่องกำเนิดไฟฟ้าเข้าสู่ระบบ	46
บทที่ 5 สรุปผลการทดลองปัญหาและข้อเสนอแนะ	
5.1 ผลการทดลองที่ 1 เครื่องกำเนิดไฟฟ้าขณะที่ไม่จ่ายโหลด	50
5.2 ผลการทดลองที่ 2 เครื่องกำเนิดไฟฟ้าขณะจ่ายโหลด	51
5.3 ผลการทดลองที่ 3 การขนานเครื่องกำเนิดไฟฟ้าเข้าสู่ระบบในสภาวะต่างๆ	52
5.4 ปัญหาที่พบระหว่างการทดลอง	54
5.5 ข้อเสนอแนะ	54
บรรณานุกรม	55
ภาคผนวก ก คู่มือการใช้งานของ Controller Generator RGK 700	56
ประวัติผู้เขียน	104

สารบัญตาราง

	หน้า
ตารางที่ 3.1 ข้อมูลจำเพาะของเครื่องกำเนิดไฟฟ้ากระแสสลับสามเฟส STC-10	29
ตารางที่ 3.2 ข้อมูลจำเพาะของเครื่องยนต์ 4 จังหวะ ขนาด 9 แรงม้า	29
ตารางที่ 4.1 ตารางการทดลองที่ 1	40
ตารางที่ 4.2 ตารางการทดลองที่ 2 ($R = 1000\Omega$)	44
ตารางที่ 4.3 เปรียบเทียบค่าจากการคำนวณกับการทดลอง	45
ตารางที่ 4.4 ก่อนทำการ Sync ขาไป (Load 40 %) ($R = 1000\Omega$)	47
ตารางที่ 4.5 หลังทำการ Sync ขาไป (Load 40 %) ($R = 1000\Omega$)	48
ตารางที่ 4.6 หลังทำการ Sync ขากลับ (Load 40 %) ($R = 1000\Omega$)	48
ตารางที่ 4.7 เปรียบเทียบค่าพารามิเตอร์ของเครื่องกำเนิดไฟฟ้าที่สภาวะต่างๆ	49
ตารางที่ 5.1 ผลการทดลองที่ 1 เครื่องกำเนิดไฟฟ้าขณะที่ไม่จ่ายโหลด	50
ตารางที่ 5.2 ผลการทดลองที่ 2 เครื่องกำเนิดไฟฟ้าขณะจ่ายโหลด ($R=1000\Omega$)	51
ตารางที่ 5.3 ผลการทดลองที่ 3 ก่อนทำการ Sync ขาไป (Load 40%) ($R=1000\Omega$)	52
ตารางที่ 5.4 ผลการทดลองที่ 3 หลังจากทำการ Sync ขาไป (Load 40%) ($R=1000\Omega$)	52
ตารางที่ 5.5 ผลการทดลองที่ 3 หลังจากทำการ Sync ขากลับ (Load 40%) ($R=1000\Omega$)	53
ตารางที่ 5.6 เปรียบเทียบค่าพารามิเตอร์ของเครื่องกำเนิดไฟฟ้าที่สภาวะต่างๆ (Load 40%) ($R=1000\Omega$)	53

สารบัญรูปภาพ

	หน้า
รูปที่ 1.1 แผนภาพการดำเนินงาน	3
รูปที่ 2.1 Synchronous Generator	4
รูปที่ 2.2 โครงของเครื่องกำเนิดไฟฟ้า (Stator)	5
รูปที่ 2.3 ร่องแบบต่าง ๆ ของแกนอาเมเจอร์	5
รูปที่ 2.4 โรเตอร์แบบขั้วแม่เหล็กยื่น	6
รูปที่ 2.5 โรเตอร์แบบขั้วแม่เหล็กเรียบรูปทรงกระบอก	7
รูปที่ 2.6 การติดตั้งขดลวดแอมแปร์ในส่วนหมุน	7
รูปที่ 2.7 การพันขดลวดเครื่องกำเนิดไฟฟ้ากระแสสลับสามเฟส แบบ Double layer	8
รูปที่ 2.8 ไดอะแกรมการต่อวงจรภายในขดลวดเครื่องกำเนิดไฟฟ้ากระแสสลับสามเฟส	8
รูปที่ 2.9 แสดงการกำหนดขั้วขดลวดเครื่องกำเนิดสามเฟส	8
รูปที่ 2.10 แสดงการกำหนดขั้วขดลวดเครื่องกำเนิดไฟฟ้าสามเฟส (Star or Y)	9
รูปที่ 2.11 แสดงการกำหนดขั้วขดลวดเครื่องกำเนิดไฟฟ้าสามเฟส (Delta or Δ)	9
รูปที่ 2.12 แสดงระบบไฟฟ้า 3 เฟส 4 สาย	9
รูปที่ 2.13 แสดงขดลวดอาเมเจอร์แบบสามเฟส	10
รูปที่ 2.14.ก ขดลวดอาเมเจอร์ของเครื่องกำเนิดสามเฟสแบบพิชเต็ม	10
รูปที่ 2.14.ข ขดลวดอาเมเจอร์ของเครื่องกำเนิดสามเฟสแบบพิชเศษส่วน	11
รูปที่ 2.15 แรงเคลื่อนไฟฟ้าที่ผลิตออกมาโดยขดลวดแต่ละชุด	11
รูปที่ 2.16 หลักการเบื้องต้นของการเหนี่ยวนำ	12
รูปที่ 2.17 การเกิดแรงเคลื่อนไฟฟ้าเหนี่ยวนำที่ตำแหน่งต่าง ๆ	12
รูปที่ 2.18 การต่อปลายขดลวดอาเมเจอร์ของเครื่องกำเนิดไฟฟ้าสามเฟส	13
รูปที่ 2.19 รูปคลื่นของแรงดันไฟฟ้าสามเฟส	14
รูปที่ 2.20 การเกิด Leakage flux ใน Slot	16
รูปที่ 2.21 การเกิด Leakage flux ใน End Connection	16
รูปที่ 2.22 การเกิด Leakage flux ใน Tooth tip of slot	16
รูปที่ 2.23 แสดงทิศทางการหมุนและความหนาแน่น (เมื่อไม่มีโหลด)	17
รูปที่ 2.24 แสดงทิศทางการหมุนและความหนาแน่น (เมื่อโหลดมีค่า P.F. = 1)	17
รูปที่ 2.25 แสดงการกระตุ้นที่ขดลวดฟิลด์	18
รูปที่ 2.26 แสดงการลดกระแสที่ขดลวดฟิลด์	18
รูปที่ 2.27 วงจรสมมูลย์ของเครื่องกำเนิดขณะมีโหลด	19
รูปที่ 2.28 เฟสเซอร์ไดอะแกรม กรณี P.F. เป็น 1	19
รูปที่ 2.29 เฟสเซอร์ไดอะแกรม กรณี P.F. lagging	19
รูปที่ 2.30 เฟสเซอร์ไดอะแกรม กรณี P.F. leading	20

สารบัญรูปภาพ (ต่อ)

	หน้า
รูปที่ 2.31 ตัวอย่างรูปแบบการควบคุมแบบอัตโนมัติ	21
รูปที่ 2.32 กระแสอาเมเจอร์ที่ P.F. ต่างๆ	22
รูปที่ 2.33 วิธีซิงโครไนส์อิมพีแดนซีในสภาวะวงจรเปิด	23
รูปที่ 2.34 วิธีซิงโครไนส์อิมพีแดนซีในสภาวะวงจรปิด	24
รูปที่ 2.35 กราฟความสัมพันธ์ระหว่าง If กับ Iscc	24
รูปที่ 2.36 อุปกรณ์ควบคุมและเครื่องกำเนิดไฟฟ้า	26
รูปที่ 3.1 เครื่องกำเนิดไฟฟ้ากระแสสลับ	28
รูปที่ 3.2 เครื่องยนต์ 4 จังหวะ ขนาด 9 แรงม้า	28
รูปที่ 3.3 ภาพชุดเครื่องกำเนิดไฟฟ้า	30
รูปที่ 3.4 Generator Controller (RGK 700)	30
รูปที่ 3.5 การวัดค่า Line-Line Voltage ของ RGK 700	31
รูปที่ 3.6 การวัดค่า Line-Line Voltage/Current ของ RGK 700	31
รูปที่ 3.7 การวัดค่า การวัดค่า Reactive Power ของ RGK 700	31
รูปที่ 3.8 การวัดค่า Energy ของ RGK 700	31
รูปที่ 3.9 การเปรียบเทียบค่าพารามิเตอร์แต่ละเฟสของ RGK 700	32
รูปที่ 3.10 การแสดงสถานะเชื้อเพลิงของ RGK 700	32
รูปที่ 3.11 การแสดงสถานะการทำงานของเครื่องยนต์ผ่าน RGK 700	32
รูปที่ 3.12 การแสดงสถานะเอาต์พุตของ RGK 700	32
รูปที่ 3.13 ไดอะแกรมการต่อเอาต์พุตและอุปกรณ์ที่สามารถต่อร่วมได้กับ RGK 700	33
รูปที่ 3.14 แบบของตู้โลหะที่ทำการออกแบบ	34
รูปที่ 3.15 ตู้โลหะจริงจากการประกอบสร้าง	34
รูปที่ 3.16 ไดอะแกรมวงจรของชุดควบคุมเครื่องกำเนิด	35
รูปที่ 3.17 Tab Power Resistor 1000 Watt 1000 Ω	36
รูปที่ 3.18 Selector Switch 5 Step 3 Pole	37
รูปที่ 3.19 ไดอะแกรมวงจรของภาระทางไฟฟ้า	37
รูปที่ 4.1 เครื่องต้นกำลัง	38
รูปที่ 4.2 เครื่องกำเนิดไฟฟ้า	39
รูปที่ 4.3. Generator Controller	39
รูปที่ 4.4. เครื่องต้นกำลัง	41
รูปที่ 4.5. เครื่องกำเนิดไฟฟ้า	41
รูปที่ 4.6. Generator Controller	41
รูปที่ 4.7. กราฟผลการทดลองที่ 2 (Power Resistor = 1000 Ω)	44
รูปที่ 4.8. อุปกรณ์ควบคุมและเครื่องกำเนิดไฟฟ้า	46

บทที่ 1

บทนำ

ในบทนี้จะกล่าวถึงที่มาและปัญหาเกี่ยวกับการศึกษาคูณลักษณะและการควบคุมเครื่องกำเนิดไฟฟ้ากระแสสลับสามเฟส ซึ่งในปัจจุบันมีเทคโนโลยีมากมายที่นำมาใช้ทดแทนการควบคุมแบบเดิม ทำให้เพิ่มประสิทธิภาพในการควบคุมมากขึ้น และกล่าวถึงวัตถุประสงค์ของโครงการขอบเขตที่ทำการศึกษาโครงการนี้ และมีขั้นตอนของการศึกษาเกี่ยวกับโครงการโดยมีแผนภาพการดำเนินการทำให้เข้าใจได้ง่ายขึ้น สุดท้ายคือประโยชน์ที่คาดว่าจะได้รับจากโครงการนี้

1.1 ความเป็นมาของปัญหา

ในปัจจุบันพลังงานไฟฟ้าเป็นพลังงานที่มีความจำเป็นอย่างยิ่ง ทั้งการดำเนินชีวิตประจำวันของมนุษย์ ในส่วนของภาคอุตสาหกรรม ซึ่งมีต้นกำเนิดของพลังงานไฟฟ้า คือ เครื่องกำเนิดไฟฟ้าทั้งกระแสตรงและกระแสสลับ แต่ในการผลิตพลังงานไฟฟ้าเพื่อจ่ายให้กับผู้ใช้จะเป็นเครื่องกำเนิดไฟฟ้ากระแสสลับสามเฟส และสิ่งที่สำคัญที่สุดในการผลิตพลังงานไฟฟ้าจากเครื่องกำเนิดไฟฟ้า คือ การควบคุมเครื่องกำเนิดไฟฟ้าโดยอาศัยความรู้ความเข้าใจในคุณลักษณะและค่าพารามิเตอร์ต่าง ๆ ซึ่งเครื่องกำเนิดไฟฟ้าแต่ละประเภทจะมีข้อแตกต่างกัน เครื่องกำเนิดไฟฟ้ากระแสสลับสามเฟสมีคุณลักษณะและค่าพารามิเตอร์ต่าง ๆ ที่จำเป็นที่จะต้องทำความเข้าใจ เพื่อที่จะสามารถออกแบบรวมไปถึงการควบคุมเครื่องกำเนิดไฟฟ้ากระแสสลับสามเฟสได้ ถ้ามีความรู้ความเข้าใจในคุณลักษณะของเครื่องกำเนิดไฟฟ้ากระแสสลับสามเฟสเป็นอย่างดีแล้ว อาจทำให้สามารถออกแบบเพื่อเพิ่มประสิทธิภาพของเครื่องกำเนิดไฟฟ้ากระแสสลับสามเฟส เพื่อลดต้นทุนในการผลิตในส่วนของการเชื่อมเพลิงลงได้

ดังนั้นการใช้ ชุดจำลองการควบคุมเครื่องกำเนิดไฟฟ้ากระแสสลับสามเฟส ประกอบกับการศึกษาคูณลักษณะของเครื่องกำเนิดไฟฟ้ากระแสสลับสามเฟส จะทำให้เกิดความรู้ความเข้าใจได้มากขึ้น และยังเพิ่มทักษะในการควบคุม การอ่านค่าพารามิเตอร์ต่าง ๆ ของเครื่องกำเนิดไฟฟ้ากระแสสลับสามเฟส ให้กับผู้ที่ทำการศึกษได้ดียิ่งขึ้น แต่ที่ผ่านมาจะเห็นได้ว่าการเรียนการสอนเกี่ยวกับเครื่องกำเนิดไฟฟ้าไม่มีตัวอย่างการใช้งานที่ชัดเจน จึงทำให้การเรียนการสอนไม่สัมฤทธิ์ผลตามเป้าหมาย ดังนั้นจึงมีความต้องการที่จะสร้าง ชุดจำลองการควบคุมเครื่องกำเนิดไฟฟ้ากระแสสลับสามเฟส ที่มีการจำลองการทำงานของเครื่องกำเนิดไฟฟ้าในสถานะจริง ทั้งขณะจ่ายโหลดและไม่มีโหลด มีการจำลองการนำเอาเครื่องกำเนิดขนานเข้าสู่ระบบหรือในปัจจุบันเรียกว่า ซิงค์ขาไป เมื่อเกิดความผิดพลาดจากระบบหลัก ซิงค์ขากลับ เมื่อระบบหลักกลับสู่สภาวะปกติแล้ว ทั้งนี้เพื่อให้ผู้ที่มาศึกษาเข้าใจคุณลักษณะและการควบคุมเครื่องกำเนิดไฟฟ้ากระแสสลับสามเฟส และยังสามารถนำไปประยุกต์ใช้ได้

1.2. วัตถุประสงค์

- 1.2.1 เพื่อเป็นอุปกรณ์ที่ช่วยในการศึกษาและวิเคราะห์คุณลักษณะของเครื่องกำเนิดไฟฟ้ากระแสสลับสามเฟส
- 1.2.2 เพื่อเป็นอุปกรณ์ที่ช่วยในการศึกษาและวิเคราะห์หลักการควบคุมเครื่องกำเนิดไฟฟ้ากระแสสลับสามเฟส
- 1.2.3 เพื่อให้เกิดแนวคิดในการพัฒนาการออกแบบหรือควบคุมเครื่องกำเนิดไฟฟ้าให้มีประสิทธิภาพมากขึ้น

1.3 ขอบเขตของการศึกษา

- 1.3.1 สร้างชุดเครื่องกำเนิดไฟฟ้ากระแสสลับสามเฟส ประกอบด้วย
 - 1.3.1.1. เครื่องยนต์เบนซิน 4 จังหวะ สูบเดียว 9 แรงม้า
 - 1.3.1.2. เครื่องกำเนิดไฟฟ้ากระแสสลับ 3 เฟส 380VAC 10kW
- 1.3.2 สร้างชุดจำลองการควบคุมเครื่องกำเนิดไฟฟ้ากระแสสลับ ประกอบด้วย
 - 1.3.2.1. ส่วนควบคุมเครื่องกำเนิดไฟฟ้า (RGK 700)
 - 1.3.2.2. ชุดจำลองภาระทางไฟฟ้า 5 ระดับ 3 เฟส 1000W 1000 Ω

1.4 ขั้นตอนของการศึกษา

- 1.4.1 กำหนดหัวข้อโครงการ
- 1.4.2 ศึกษาค้นคว้าหาข้อมูลที่เกี่ยวข้องกับโครงการ
- 1.4.3 ทบทวนวรรณกรรมที่เกี่ยวข้องกับโครงการ
- 1.4.4 ออกแบบชุดจำลองเครื่องกำเนิดไฟฟ้าสามเฟส
- 1.4.5 ตรวจสอบงบประมาณที่ใช้ในโครงการ
- 1.4.6 ปรึกษาอาจารย์ที่ปรึกษา
- 1.4.7 ยื่นเสนอหัวข้อโครงการต่อคณะกรรมการ
- 1.4.8 ดำเนินการสร้างชุดจำลองเครื่องกำเนิดไฟฟ้าสามเฟส
- 1.4.9 ทดสอบความถูกต้องของโครงการตามที่ได้ออกแบบไว้
- 1.4.10 บันทึกผลที่ได้จากการทดสอบ
- 1.4.11 วิเคราะห์และสรุปผลการทดสอบ
- 1.4.12 เรียบเรียงเอกสารโครงการ
- 1.4.13 จัดทำปฏิญานินพนธ์

แผนภาพการดำเนินงาน

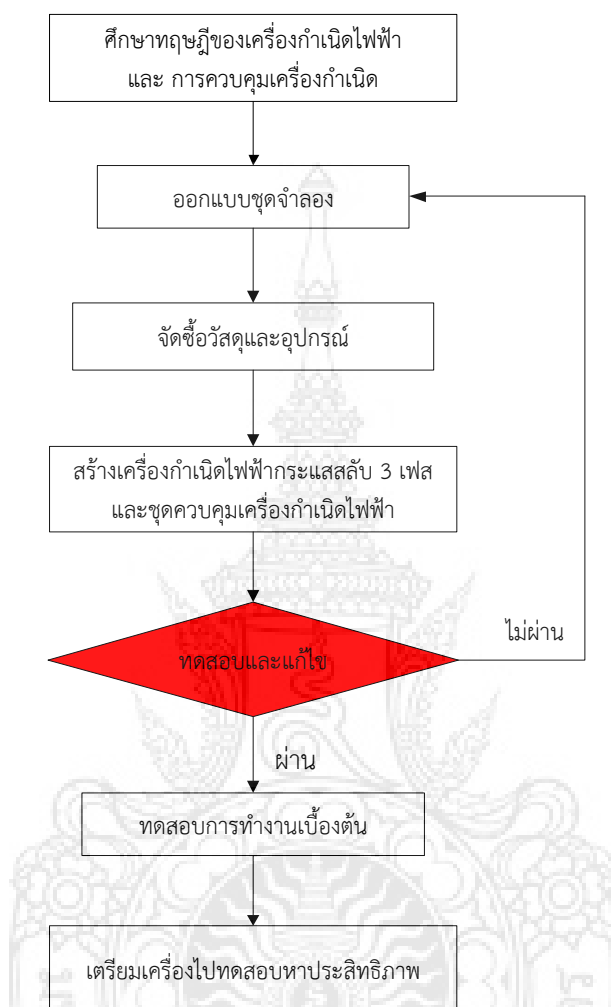

รูปที่ 1.1 แผนภาพการดำเนินงาน

1.5 ประโยชน์ที่คาดว่าจะได้รับ

- 1.5.1 ทำให้มีความรู้ความเข้าใจในการศึกษาคุณลักษณะของเครื่องกำเนิดไฟฟ้ากระแสสลับสามเฟสในสถานะต่าง ๆ ได้มากขึ้น
- 1.5.2 ทำให้มีความรู้ความเข้าใจในการควบคุมเครื่องกำเนิดไฟฟ้ากระแสสลับสามเฟสในสถานะต่าง ๆ ได้มากขึ้น
- 1.5.3 ทำให้เกิดแนวคิดในการพัฒนาการออกแบบหรือควบคุมเครื่องกำเนิดไฟฟ้าให้มีประสิทธิภาพมากขึ้น

บทที่ 2 ทฤษฎีที่เกี่ยวข้อง

ในบทนี้จะกล่าวถึงทฤษฎีที่นำมาใช้ในโครงการนี้ โดยมีทฤษฎีที่เกี่ยวข้องกับเครื่องกำเนิดไฟฟ้ากระแสสลับสามเฟส แบ่งเป็น โครงสร้างของเครื่องกำเนิดไฟฟ้ากระแสสลับ กล่าวถึงโครงสร้างและส่วนประกอบโดยทั่วไปของเครื่องกำเนิดไฟฟ้า ขดลวดของเครื่องกำเนิดไฟฟ้าสามเฟสกล่าวถึงรูปแบบของเครื่องกำเนิดไฟฟ้าสามเฟส คุณสมบัติของเครื่องกำเนิดไฟฟ้ากระแสสลับกล่าวถึงคุณลักษณะและพฤติกรรมต่าง ๆ ของเครื่องกำเนิดไฟฟ้าในสถานะต่าง ๆ ในการทำงาน การควบคุมเครื่องกำเนิดไฟฟ้า กล่าวถึงหลักการและรูปแบบในการควบคุม และสุดท้ายการขนานเครื่องกำเนิดไฟฟ้าเข้าสู่ระบบกล่าวถึงหลักการและรูปแบบการขนานเครื่องกำเนิดไฟฟ้าเข้าสู่ระบบเมื่อเกิดความผิดพลาดจากระบบจ่ายไฟหลัก

2.1. เครื่องกำเนิดไฟฟ้ากระแสสลับสามเฟส

เครื่องกำเนิดไฟฟ้ากระแสสลับและเครื่องกำเนิดไฟฟ้ากระแสตรงทำหน้าที่เหมือนกัน คือผลิตแรงดันไฟฟ้า แต่มีข้อแตกต่างกันคือ เครื่องกำเนิดไฟฟ้ากระแสตรง ขดลวดอาเมเจอร์ เป็นส่วนหมุนและขดลวดสนามแม่เหล็กเป็นส่วนที่อยู่กับที่ ส่วนเครื่องกำเนิดไฟฟ้ากระแสสลับ อาจจะใช้ขดลวดอาเมเจอร์เป็นส่วนหมุน หรือส่วนที่อยู่กับที่ก็ได้ เครื่องกำเนิดไฟฟ้ากระแสสลับส่วนใหญ่เป็นขั้วแม่เหล็กหมุนเพราะว่า

1. กระแสที่นำไปใช้กับโหลด ไม่ต้องผ่านสปรिंग จึงลดปัญหาเรื่องฉนวนไฟฟ้า
2. ผลิตแรงดันได้สูงถึง 30 kV
3. ขนาดของส่วนหมุนลดลง ขนาดพื้นที่หน้าตัดขดลวดอาเมเจอร์น้อยกว่าขดลวดสนามแม่เหล็ก จึงใช้กระแสฟลักซ์น้อยประมาณ 100 ถึง 250 โวลต์

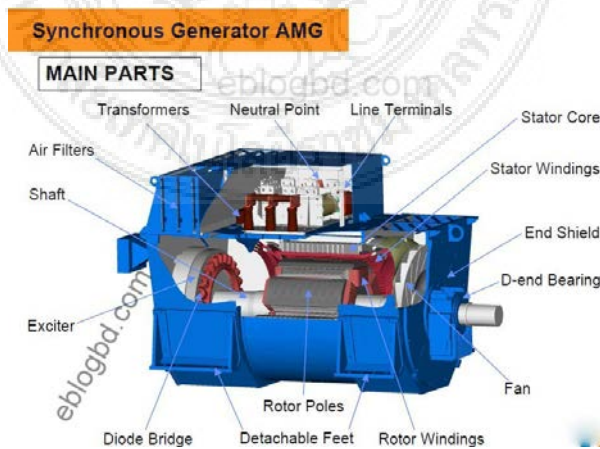

รูปที่ 2.1 Synchronous Generator

2.1.1 โครงสร้างของเครื่องกำเนิดไฟฟ้ากระแสสลับสามเฟส

ส่วนประกอบเครื่องกำเนิดไฟฟ้าแบบขั้วแม่เหล็กหมุน

1. โครงเครื่อง (Stator frame)

เป็นส่วนรองรับส่วนประกอบอื่น ๆ ของเครื่องกำเนิดไฟฟ้าทำด้วยเหล็กหล่อ ในเครื่องที่มีการหมุนตัวมีขนาดเส้นผ่านศูนย์กลางโตและมีช่องระบายความร้อน ดังรูปที่ 2.2

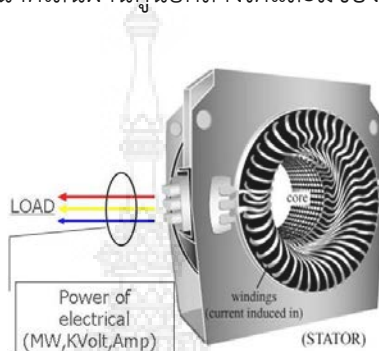

รูปที่ 2.2 โครงของเครื่องกำเนิดไฟฟ้า (Stator)

2. แกนเหล็กสเตเตอร์ (Stator Core)

เป็นส่วนที่ใช้พันขดลวดอะเมเจอร์ทำด้วยเหล็กแผ่นบาง ๆ (Laminated sheet steel) ปั้นเป็นร่อง (slot) สำหรับพันขดลวดเพื่อลดการสูญเสียจากกระแสไหลวน (Eddy Current) ในเครื่องกำเนิดไฟฟ้าขนาดใหญ่ที่แกนเหล็กอะเมเจอร์มีช่องสำหรับให้อากาศผ่านเพื่อช่วยระบายความร้อนร่องแบบต่าง ๆ ของแกนอะเมเจอร์แสดงดังรูปที่ 2.3



แกนเหล็กสเตเตอร์ของเครื่องกำเนิดไฟฟ้าเหนี่ยวนำ

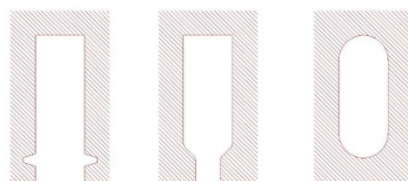

ก. แบบเปิด ข. แบบกึ่งเปิด ค. แบบปิด

รูปที่ 2.3 ร่องแบบต่าง ๆ ของแกนอะเมเจอร์

สำหรับลักษณะของร่องที่ใช้พันขดลวด

1. ร่องแบบเปิด (Wide-Open type slot) เป็นร่องที่นิยมใช้ในเครื่องกำเนิดไฟฟ้ากระแสตรงมีข้อดีคือ ง่ายต่อการบรรจุขดลวด และง่ายต่อการซ่อม แต่ข้อเสียคือเส้นแรงแม่เหล็กที่ช่องว่าง (Air-gap flux) ทำให้รูปคลื่นแรงเคลื่อนไฟฟ้าเหนี่ยวนำเกิดการกระเพื่อม (Ripple)
2. ร่องแบบกึ่งปิด (Semi-closed type slot) เป็นร่องที่ดีกว่าร่องแบบเปิดจะพันขดลวดจากแบบแล้วจึงบรรจุลงในร่อง
3. ร่องแบบปิด (Closed type slot) เป็นร่องที่เจาะเป็นอุโมงค์และทำให้ ค่าอิมพีแดนซ์ลดลง

3. ส่วนที่หมุนหรือขั้วแม่เหล็กหมุน (Rotating field)

1. แบบขั้วแม่เหล็กยื่น (Salient pole type)

เหมาะสำหรับเครื่องกำเนิดไฟฟ้าที่ขับเคลื่อนด้วยความเร็วปานกลางถึงความเร็วสูงสุดโดยประกอบด้วยขั้วแม่เหล็กมากกว่า 4 ขั้วขึ้นไป โครงสร้างทำด้วยแผ่นเหล็กบาง ๆ (Laminated sheet steel) อัดเป็นแท่งยึดด้วยสลักเกลียวเพื่อลดความร้อนจากกระแสไหลวน ลักษณะของส่วนที่หมุน (Rotor) แบบนี้จะมีขนาดเส้นผ่านศูนย์กลางใหญ่ดังรูปที่ 2.4

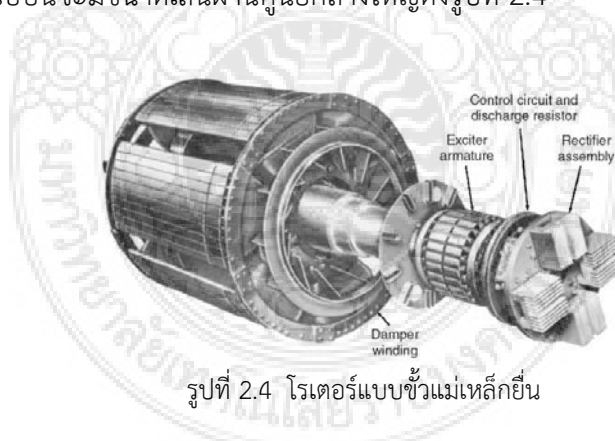

รูปที่ 2.4 โรเตอร์แบบขั้วแม่เหล็กยื่น

2. แบบขั้วแม่เหล็กเรียบรูปทรงกระบอก (Cylindrical rotor or non-salient pole)

เหมาะสมกับเครื่องกำเนิดไฟฟ้าที่เคลื่อนที่ด้วยความเร็วสูงประมาณ 3000 รอบต่อนาที จะมีขั้วแม่เหล็ก 2-4 ขั้ว โครงสร้างเป็นรูปทรงกระบอกมีผิวเรียบ ขั้วแม่เหล็กอยู่ที่ร่องบนตัวหมุนเนื่องจากหมุนด้วยความเร็วสูงและลดแรงหนีศูนย์กลางได้ ดังรูปที่ 2.5

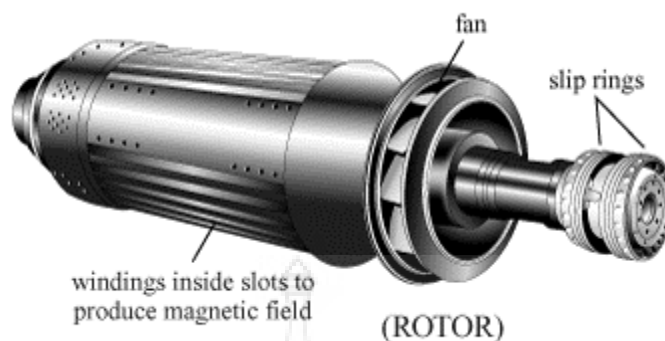

รูปที่ 2.5 โรเตอร์แบบขั้วแม่เหล็กเรียบรูปทรงกระบอก

4. ขดลวดแดมเปอร์ (Damper winding)

ที่ขั้วแม่เหล็กของส่วนที่หมุนจะมีร่องสำหรับฝังแท่งทองแดงและปลายแท่งจะทำการลัดวงจรด้วยวงแหวนทองแดงมีลักษณะเหมือนกับโครงกรงกระรอก (Squirrel-cage winding) ขดลวดแดมเปอร์นี้ช่วยในการลดการแกว่งหรือสั่นขณะมีการเริ่มทำงาน ด้วยความเร็วไม่สม่ำเสมอ โดยขดลวดจะสร้างสนามแม่เหล็กออกมาต้านกับสนามแม่เหล็กหมุนทำให้การสั่นหรือการแกว่ง หยุดได้เร็วขึ้น ลักษณะการติดตั้งขดลวดแดมเปอร์ในส่วนหมุนดังรูปที่ 2.6



รูปที่ 2.6 การติดตั้งขดลวดแดมเปอร์ในส่วนหมุน

2.1.2 ขดลวดของเครื่องกำเนิดไฟฟ้าสามเฟส (Three Phase Winding)

2.1.2.1 ขดลวดสเตเตอร์ของเครื่องกำเนิดไฟฟ้าสามเฟส

ขดลวดสเตเตอร์ของเครื่องกำเนิดไฟฟ้า 3 เฟส ประกอบด้วยขดลวด 3 ชุด คือขดลวดเฟส A (U1-U2) ขดลวดเฟส B (V1-V2) และ ขดลวดเฟส C (W1-W2) ที่มีลักษณะเหมือนกันทุกประการ วางในสล็อตห่างกัน 120 องศาไฟฟ้า

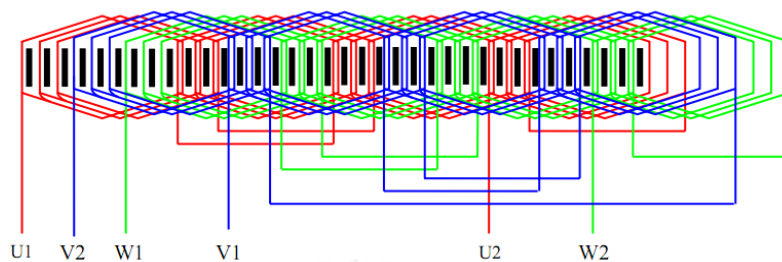

รูปที่ 2.7 การพันขดลวดเครื่องกำเนิดไฟฟ้ากระแสสลับสามเฟส 36 Slot แบบ Double layer

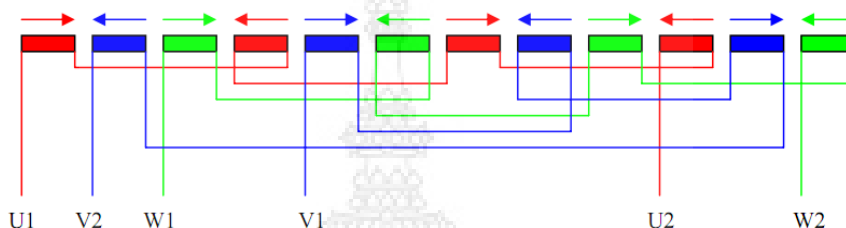

รูปที่ 2.8 ไดอะแกรมการต่อวงจรภายในขดลวดเครื่องกำเนิดไฟฟ้ากระแสสลับสามเฟส 4 ขั้ว

การต่อวงจรใช้งาน จากการต่อวงจรภายในเครื่องกำเนิดไฟฟ้า 3 เฟส รูปที่ 2.8 เขียนเป็นสัญลักษณ์และวางตำแหน่งขั้วเครื่องกำเนิดไฟฟ้าได้ดังนี้

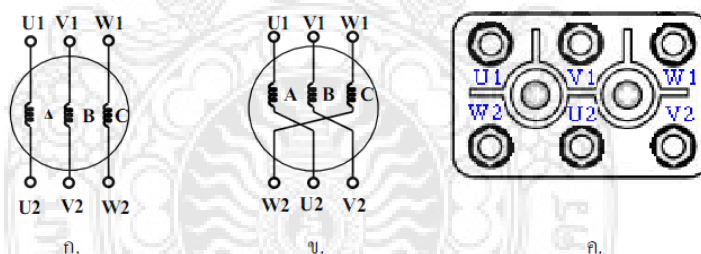

รูปที่ 2.9 แสดงการกำหนดขั้วขดลวดเครื่องกำเนิดไฟฟ้าสามเฟส
ก. สัญลักษณ์ขดลวด ข. การวางตำแหน่งขั้ว ค. ขั้วต่อสาย

การต่อวงจรใช้งานเครื่องกำเนิดไฟฟ้า 3 เฟส สามารถต่อวงจรได้ 2 แบบคือ แบบสตาร์ (Star หรือ Y) และแบบ เดลต้า (Delta หรือ Δ)

1. การต่อแบบสตาร์ (Star or Y) ต่อปลายด้านเดียวกันของขดลวดทั้ง 3 เข้าด้วยกันซึ่งจุดต่อนี้จะเป็นสายนิวตรอนของเครื่องกำเนิดด้วย แล้วจ่ายไฟเข้าที่อีกด้านของขดลวด

L1 ต่อกับ U1, L2 ต่อกับ V1, L3 ต่อกับ W1

N ต่อกับ U2, V2 และ W2

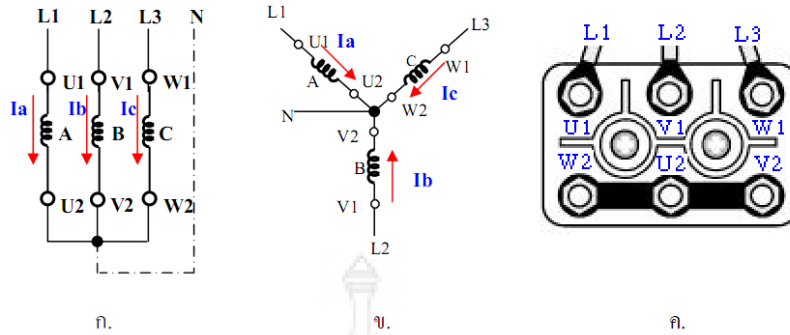

รูปที่ 2.10 แสดงการกำหนดขั้วขดลวดเครื่องกำเนิดสามเฟส (Star or Y)
 ก. การต่อวงจร ข. สัญลักษณ์วงจร ค. การจัดขั้วเครื่องกำเนิด

2. การต่อแบบเดลต้า (Delta or Δ) ต่อปลายสายเฟส A (U2) เข้ากับต้นสายของเฟส B (V1) ต่อปลายสายเฟส B (V2) เข้ากับ ต้นสายของเฟส C (W1) ต่อปลายสายเฟส C (W2) เข้ากับต้นสายของเฟส A (U1)

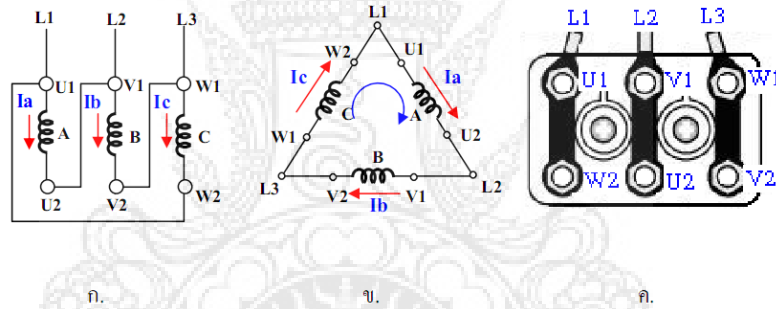

รูปที่ 2.11 แสดงการกำหนดขั้วขดลวดเครื่องกำเนิดสามเฟส (Delta or Δ)
 ก. การต่อวงจร ข. สัญลักษณ์วงจร ค. การจัดขั้วเครื่องกำเนิด

- L1 ต่อกับ U1 และ W2
- L2 ต่อกับ V1 และ U2
- L3 ต่อกับ W1 และ V2

การกำหนดแรงดันไฟฟ้าที่เครื่องกำเนิดไฟฟ้าให้สอดคล้องกับแรงดันระบบ ระบบไฟฟ้ากำลัง 3 เฟส มาตรฐานทั่วไปที่การไฟฟ้าทั้งส่วนภูมิภาค และนครหลวงจ่ายให้ผู้ใช้งานส่วนใหญ่เป็นระบบ 3 เฟส 4 สาย ดังนี้

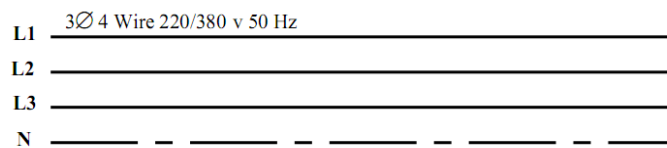

รูปที่ 2.12 แสดงระบบไฟฟ้า 3 เฟส 4 สาย

แรงดันระหว่าง L1, L2 = 380 v	แรงดันระหว่าง L1, N = 220 v
แรงดันระหว่าง L2, L3 = 380 v	แรงดันระหว่าง L2, N = 220 v
แรงดันระหว่าง L3, L1 = 380 v	แรงดันระหว่าง L3, N = 220 v

2.1.2.2 ขดลวดอาเมเจอร์ของเครื่องกำเนิดไฟฟ้าสามเฟส

ขดลวดอาเมเจอร์แบบสามเฟส คือ ขดลวดอาเมเจอร์แบบหนึ่งเฟส 3 ชุดอยู่ในร่องภายใต้ขั้วแม่เหล็ก 1 ขั้ว ดังรูปที่ 2.13 ขดลวดแต่ละชุดจะพันเรียงห่างกัน 120 องศาไฟฟ้าแต่ละ Coil-Group ประกอบด้วยขดลวด 4 ขดต่ออนุกรมหรือมีจำนวนคอยล์ 4 Coil/Group

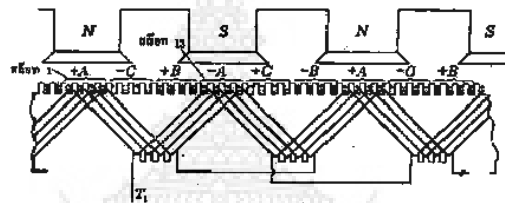

รูปที่ 2.13. แสดงขดลวดอาเมเจอร์แบบสามเฟส

1. ขดลวดอาเมเจอร์ของเครื่องกำเนิดสามเฟสแบบพิชเต็ม

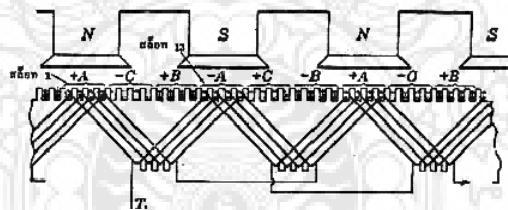

รูปที่ 2.14.ก ขดลวดอาเมเจอร์ของเครื่องกำเนิดสามเฟสแบบพิชเต็ม

จากรูปที่ 2.14 ขดลวดแต่ละชุดจะพันลงในสล๊อตห่างกัน 120 องศาไฟฟ้า จำนวนสล๊อตต่อหนึ่งขั้วแม่เหล็กมีค่าเท่ากับ 12 สล๊อต ดังนั้น จำนวนสล๊อตต่อหนึ่งขั้วแม่เหล็กต่อหนึ่งเฟส มีค่าเท่ากับ 4 สล๊อต และขั้วแม่เหล็ก 1 ขั้วกว้าง 180 องศาไฟฟ้าหรือต้นและปลายของขดลวดเดียวกันพันห่างกัน 180 องศาไฟฟ้า ดังนั้น สล๊อตแต่ละสล๊อตห่างเท่ากับ $180/12 = 15$ องศาไฟฟ้า การพันขดลวดในเฟส a จะเริ่มที่สล๊อตที่ 1 ส่วนปลายของคอยล์ที่ 1 จะพันลงในด้านล่างของสล๊อตที่ 13 ในทำนองเดียวกันต้นของคอยล์ที่ 2 จะเริ่มที่สล๊อตที่ 2 และปลายคอยล์จะลงสล๊อตที่ 14 เป็นอย่างนี้เรื่อย ๆ ไป พันจนหมดทุกเฟส ขดลวดที่พันจะเป็นเฟสเดียวกันทั้งชุดที่อยู่ด้านบนและชุดที่อยู่ด้านล่าง

2. ขดลวดอามเมอร์ของเครื่องกำเนิดสามเฟสแบบพิเศษส่วน

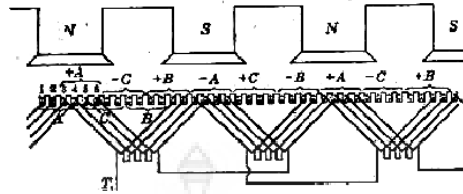

รูปที่ 2.14.ข ขดลวดอามเมอร์ของเครื่องกำเนิดสามเฟสแบบพิเศษส่วน

คือ ระยะห่างระหว่างต้นและปลายของคอยล์เดียวกัน ที่พื้นลงในสล๊อทของขดลวดอามเมอร์มีค่าน้อยกว่า 180 องศาไฟฟ้า หรือระยะห่างน้อยกว่า 12 สล๊อท มีระยะห่างเพียง 10 สล๊อท นั่นคือ ระยะห่างหรือพิชเป็น $10/12 = 5/6$ ของขดลวดดังรูปที่ 2.14

จากรูปการพันขดลวดของแต่ละเฟส ต้นของเฟส a มีปลายของเฟส a มาลงเพียง 2 คอยล์เท่านั้น ส่วนอีกสองสล๊อทต้นของเฟส a ที่เหลือไปทางขวามือจะมีปลายของเฟส c มาลงอีกสองคอยล์ เมื่อนำการพันขดลวดทั้ง 2 แบบไปใช้งานแรงเคลื่อนไฟฟ้าที่ผลิตออกมา โดยขดลวดแต่ละชุดจะมีความแตกต่างกันดังรูปที่ 2.15

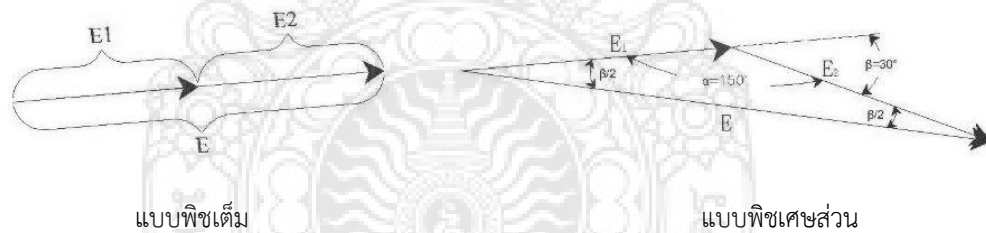

รูปที่ 2.15 แรงเคลื่อนไฟฟ้าที่ผลิตออกมาโดยขดลวดแต่ละชุด

2.1.3 คุณสมบัติของเครื่องกำเนิดไฟฟ้ากระแสสลับสามเฟส

2.1.3.1 แรงเคลื่อนไฟฟ้าเหนี่ยวนำรูปคลื่นไซน์และองศาไฟฟ้า

1. แรงเคลื่อนไฟฟ้าเหนี่ยวนำรูปคลื่นไซน์

จากรูปที่ 2.16.ก ขั้วแม่เหล็กมีความหนาแน่นเส้นแรงแม่เหล็กมากที่สุดที่กึ่งกลางขั้วและความหนาแน่นน้อยลงไปตามด้านข้างทั้ง 2 ขั้วแม่เหล็ก เมื่อวางอยู่ในตำแหน่งศูนย์

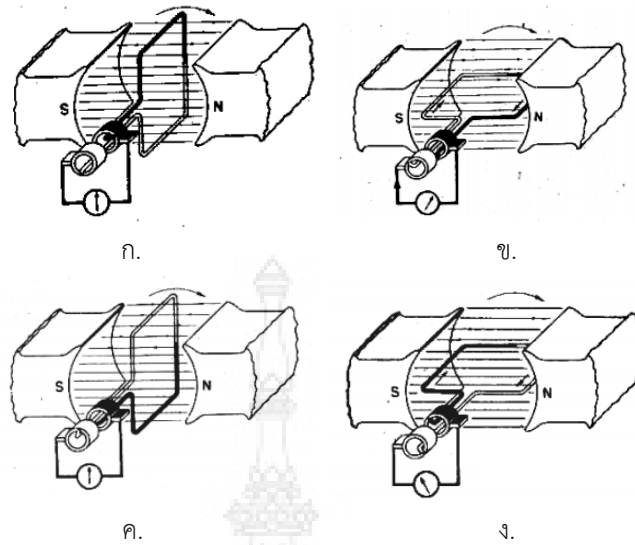

รูปที่ 2.16 หลักการเบื้องต้นของการเหนี่ยวนำ

ระหว่างขั้วแม่เหล็ก N-S จะไม่มีเส้นแรงแม่เหล็กตัดขดลวด เนื่องจากขดลวดวางขนานกับเส้นแรงแม่เหล็ก ทำให้ไม่เกิดแรงเคลื่อนไฟฟ้า เมื่อหมุนขดลวดไปเรื่อยแรงเคลื่อนไฟฟ้าเหนี่ยวนำจะเพิ่มขึ้นเรื่อย จนมากที่สุดเมื่อขดลวดตั้งฉากกับเส้นแรงแม่เหล็กดัง รูปที่ 2.16.ข เมื่อขดลวดเคลื่อนที่ต่อไป

เส้นแรงแม่เหล็กตัดขดลวดน้อยลงทำให้ แรงเคลื่อนไฟฟ้าลดลง เมื่ออยู่ในตำแหน่งดังในรูปที่ 2.16.ค

เมื่อขดลวดเคลื่อนที่ต่อไป จะทำให้เส้นแรงแม่เหล็กตัดขดลวดมากขึ้น ทำให้แรงเคลื่อนไฟฟ้าเพิ่มขึ้นเรื่อย ๆ จนถึงค่าสูงสุดดังรูปที่ 2.16.ง

เนื่องจากตัวต้นกำเนิดหมุนอยู่ตลอดเวลา ดังนั้นทำให้แรงเคลื่อนไฟฟ้าที่ได้มีลักษณะเป็นรูปคลื่นไซน์ มีแรงเคลื่อนสูงสุดและต่ำสุด ดังรูปที่ 2.17 รูปคลื่นดังกล่าวจะเกิดขึ้นเป็นคาบเวลา เรียกว่า หนึ่งไซเคิล

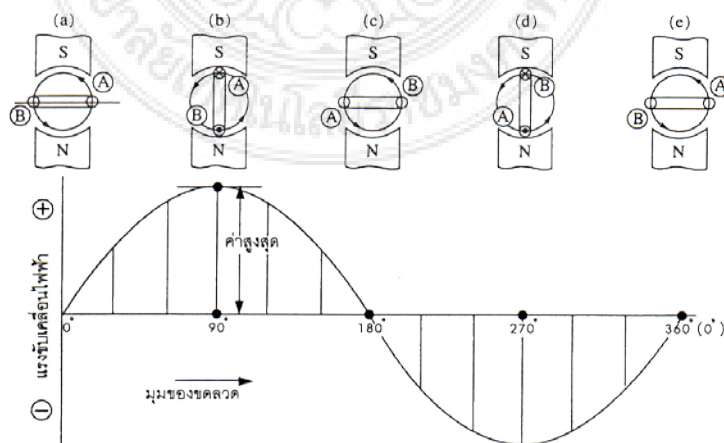

รูปที่ 2.17 การเกิดแรงเคลื่อนไฟฟ้าเหนี่ยวนำที่ตำแหน่งต่าง ๆ

2. องศาไฟฟ้า

เครื่องกำเนิดไฟฟ้า จะประกอบด้วย ขั้วแม่เหล็ก 1 คู่ และขดลวดอาเมเจอร์ 1 ชุด เมื่อขดลวดอาเมเจอร์เคลื่อนที่หมุนครบ 1 รอบ จะได้มุม 360 องศา จำนวนองศาไฟฟ้ามีค่าเท่ากับจำนวนองศาทางกล แต่เมื่อมีขั้วแม่เหล็กขึ้น 2,4,...n คู่ จำนวนองศาทางไฟฟ้าจะเป็น 2,3,4,...,n เท่า ของจำนวนองศาทางไฟฟ้าของขั้วแม่เหล็ก 1 คู่

องศาทางไฟฟ้า = องศาทางกล \times จำนวนคู่ของขั้วแม่เหล็ก

2.1.3.2 ความสัมพันธ์ระหว่าง ความเร็ว (N) ความถี่ (f) จำนวนโพล (P)

ตัวนำที่ตัดเส้นแรงแม่เหล็ก 1 รอบ ในจำนวนขั้วแม่เหล็ก จะได้รูปคลื่นของแรงเคลื่อนไฟฟ้าออกมา 1 รอบ

ให้	P	=	จำนวนขั้วแม่เหล็ก
	N	=	ความเร็วรอบ (รอบต่อนาที)
จำนวนรอบต่อการเคลื่อนที่	=	P/2	
และการเคลื่อนที่ต่อวินาที	=	N/60	
จำนวนรอบต่อนาที	=	(P/2) \times (N/60)	
	N	=	(120f)/P rpm
	f	=	(PN)/120 Hz

2.1.4 แรงเคลื่อนไฟฟ้าเหนี่ยวนำเครื่องกำเนิดไฟฟ้ากระแสสลับสามเฟส

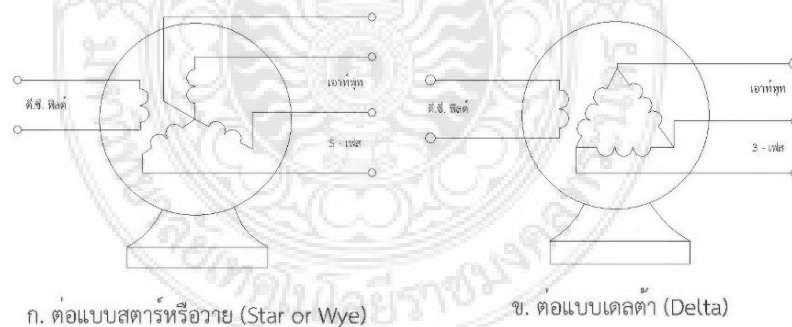

ต่อแบบสตาร์

ต่อแบบเดลต้า

รูปที่ 2.18 การต่อปลายขดลวดอาเมเจอร์ของเครื่องกำเนิดไฟฟ้าสามเฟส

แรงเคลื่อนไฟฟ้าเหนี่ยวนำที่ได้ในแต่ละเฟส เหมือนกับเครื่องกำเนิดไฟฟ้า 1 เฟส แต่ต่างกันตรงที่ การต่อปลายขดลวดอาเมเจอร์ซึ่งมี 2 แบบคือ สตาร์และเดลต้า ดังรูปที่ 2.18 การหาค่าแรงดันเฟสและแรงดันสายจึงมีค่าต่างกัน ดังนี้

2.1.4.1 แบบสตาร์ – เดลต้า

$$E_{\text{LINE}} = \sqrt{3} \times E_{\text{PHASE}}$$

$$I_{\text{LINE}} = I_{\text{PHASE}}$$

2.1.4.2 แบบสตาร์ – สตาร์

$$E_{\text{LINE}} = E_{\text{PHASE}}$$

$$I_{\text{LINE}} = \sqrt{3} \times I_{\text{PHASE}}$$

และรูปคลื่นแรงดันไฟฟ้ากระแสสลับที่ได้จากเครื่องกำเนิดไฟฟ้ากระแสสลับ 3 เฟส จะทำมุมต่างกัน 120 องศา แสดงดังรูปที่ 2.19

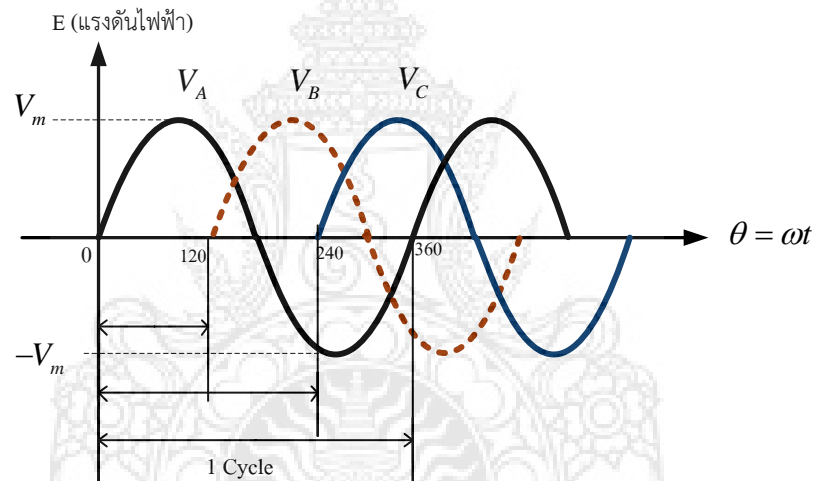

รูปที่ 2.19 รูปคลื่นของแรงดันไฟฟ้าสามเฟส

2.1.5 การทำงานของเครื่องกำเนิดไฟฟ้ากระแสสลับสามเฟส

2.1.5.1 ขณะที่ไม่มีโหลด (No - Load)

เครื่องกำเนิดไฟฟ้ากระแสสลับทำงานขณะที่ไม่มีโหลด ที่ปลายสายไม่มีโหลดต่ออยู่ แรงดันไฟฟ้าที่ปลายสายของขดลวดแต่ละเฟส จะมีค่าเท่ากับแรงเคลื่อนไฟฟ้าเหนี่ยวนำที่ขดลวดอามแปจอร์แต่ละเฟส

$$V = E_{\text{PHASE}} = 4.44 \times f \times N \times \phi \times K_p \times K_D$$

เมื่อไม่มีโหลดต่อที่ปลายขดลวดอามแปจอร์ ทำให้วงจรขดลวดอามแปจอร์ไม่ครบวงจร ทำให้ไม่มีกระแสเหนี่ยวนำเกิดขึ้น ดังนั้น

$$I = 0$$

2.1.5.2 ขณะที่มีโหลด (On - load)

เมื่อมีโหลดมาต่อเข้ากับปลายสายเครื่องกำเนิดไฟฟ้า ขณะเครื่องกำเนิดไฟฟ้าสร้างแรงเคลื่อนไฟฟ้าเหนี่ยวนำ ทำให้แรงดันไฟฟ้าที่ปลายสายลดลง ทำให้มีกระแสไหลครบวงจร ออเมเจอร์ สาเหตุที่ทำให้แรงดันไฟฟ้าปลายสายลดลง มีดังนี้

1. Armature Resistance ($I_a R_a$)

ตามปกติการพันขดลวด ที่ลึงสล๊อทของสเตเตอร์ มีความยาวทำให้เกิดความต้านทานขึ้น ดังนั้นเมื่อกระแสไหลในออเมเจอร์ จะทำให้เกิดแรงดันตกคร่อม (IARA) ตามปกติ ความต้านทานประสิทธิผล (Effective Resistance) มีค่าสูงกว่าความต้านทานกระแสตรง ประมาณ 115 - 175 % ในทางคำนวณใช้ค่าประมาณ 150 % ทางการค้าในเครื่องกำเนิดไฟฟ้าขนาดใหญ่ ค่า Armature Resistance ไม่คิดเพราะน้อยมากเมื่อเทียบกับค่า Reactance ($X_S = X_A + X_L$)

$$R_{ac} = 1.5 \times R_{dc}$$

2. Leakage flux Reactance ($I_a X_L$)

เมื่อกระแสไหลเข้าสู่ขดลวด จำนวนรอบการพันขดลวดทำให้เกิด Leakage Flux ซึ่ง Flux นี้จะไปเหนี่ยวนำจำนวนรอบการพันของอีกขดลวดหนึ่ง ทำให้เกิดค่า Inductance ของขดลวดขึ้น

$$X_L = 2\pi fL$$

เมื่อกระแสไหลผ่านทำให้เกิด Reactance Drop

$$X_L = 2\pi fL$$

การเกิด Leakage Flux Reactance มีสาเหตุอยู่ 3 ประการคือ

Slot Reactance แต่ละจำนวนรอบของขดลวด จะสร้าง Flux ซึ่ง Flux จะไปเหนี่ยวนำกับขดลวดอื่น ๆ ดังนั้นถ้า Slot แคบและลึกทำให้ Reluctance ค่า สร้าง Flux ขึ้นมาได้มาก จึงเกิด Reactance สูง ดังรูปที่ 2.20

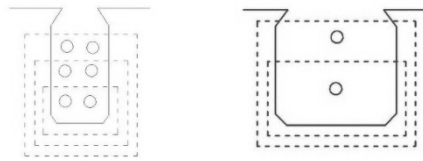

เปรียบเทียบ slot ขนาดใหญ่และขนาดเล็กที่บรรจุขดลวด

รูปที่ 2.20 การเกิด Leakage Flux ใน Slot

วิธีแก้ไขสร้าง Slot ให้มีขนาดใหญ่กว่าและตั้ง Reactance จะต่ำ End Connection Reactance แต่ละการพันขดลวด ที่พื้นเมื่อมีกระแสผ่าน Flux ยิ่ง End Connection ยาวจะทำให้ Reactance สูง ดังรูปที่ 2.21

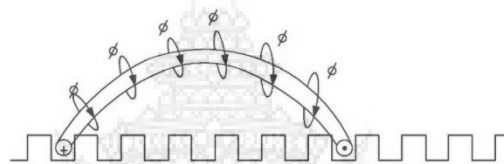

End connection reactance แต่ละการพันขดลวด

รูปที่ 2.21 การเกิด Leakage Flux ใน End Connection

Tooth Tip of Slot Reactance ตำแหน่งของขั้วแม่เหล็กตรงกับขดลวดในร่องสล๊อท ทำให้ Flux มากเพราะมีค่า Reluctance ต่ำ และตรงข้ามกันคือ Flux ต่ำ Reluctance สูง ดังรูปที่ 2.22

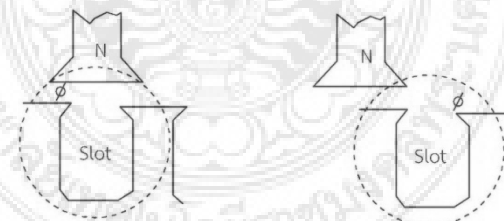

เปรียบเทียบตำแหน่งของขั้วแม่เหล็กกับร่องสล๊อท

รูปที่ 2.22 การเกิด Leakage Flux ใน Tooth Tip of Slot

3. Armature Reaction ($I_a X_a$)

เครื่องกำเนิดไฟฟ้ากระแสสลับ Armature Reaction เกิดขึ้นจากกระแสไฟฟ้าที่ไหลเข้าไปยังขดลวดอาเมเจอร์ ซึ่งจะสร้าง สนามแม่เหล็กเหนี่ยวนำ ซึ่งมีทิศทางเสริมหรือต้านกับสนามแม่เหล็กเหนี่ยวนำที่สร้างขึ้นจากขั้วแม่เหล็ก จะมีอยู่ 3 ลักษณะคือ

1. โหลดมีค่า P.F. เป็น 1 (Unity P.F.) กระแสและแรงเคลื่อนไฟฟ้าเหนี่ยวนำมีเฟสเดียวกัน (Inphase) เมื่อขดลวดสนามแม่เหล็กหมุน จะเกิดแรงเคลื่อนไฟฟ้าเหนี่ยวนำสูงสุด เนื่องจากขดลวดอาเมเจอร์เคลื่อนที่ตัดกับเส้นแรงแม่เหล็กตรงกึ่งกลางขั้วพอดิ ดังรูปที่ 2.23 แต่ไม่มีกระแสไหล

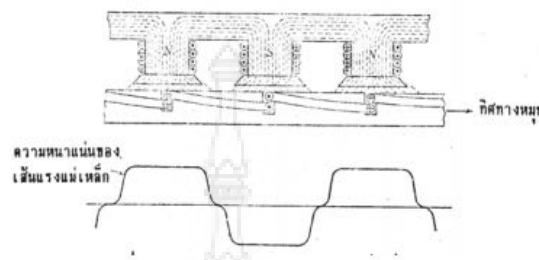

รูปที่ 2.23 แสดงทิศทางการหมุนและความหนาแน่นของสนามแม่เหล็กเมื่อยังไม่ต่อโหลด

ผ่านขดลวดอาเมเจอร์ ความหนาแน่นของเส้นแรงแม่เหล็กจะสมมาตรเมื่อต่อโหลดเข้าไป จะมีกระแสไหลผ่านขดลวดอาเมเจอร์ทำให้เส้นแรงแม่เหล็กขั้ว N และ S จะบิดเบนไป ความหนาแน่นเส้นแรงแม่เหล็กด้านซ้ายมือจะน้อยกว่าด้านขวามือ ดังรูปที่ 2.24

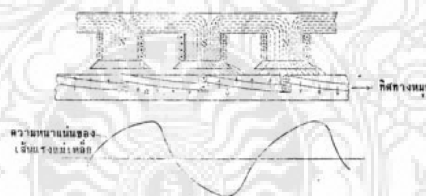

รูปที่ 2.24 แสดงทิศทางการหมุนและความหนาแน่นของสนามแม่เหล็กเมื่อโหลดมีค่า P.F. เป็น 1

2. โหลดมีค่า P.F. Lagging กระแสล้าหลังแรงดันไฟฟ้า ประมาณ 90 องศา เส้นแรงแม่เหล็กที่เกิดขึ้นจากอาเมเจอร์มีทิศทางตรงข้ามกับเส้นแรงแม่เหล็กที่ขั้วแม่เหล็ก ทำให้เส้นแรงแม่เหล็กที่ขั้วแม่เหล็กลดลง ทำให้แรงเคลื่อนไฟฟ้าเหนี่ยวนำมีค่าลดลงด้วย ในกรณีจะต้องเพิ่มการกระตุ้นที่ขดลวดฟิลด์คอยล์ เพื่อให้แรงเคลื่อนไฟฟ้าเหนี่ยวนำสูงขึ้น ดังรูปที่ 2.25

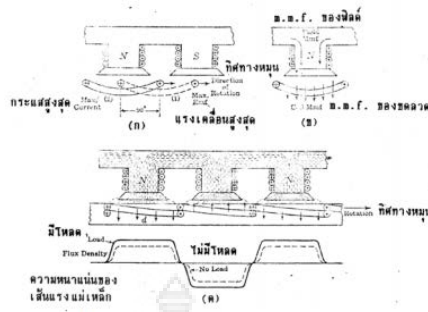

รูปที่ 2.25 แสดงการกระตุ้นที่ขดลวดฟิลต์ทำให้แรงเคลื่อนไฟฟ้าเหนี่ยวนำสูงขึ้น

3. โหลดมีค่า P.F. Leading กระแสจะนำหน้าแรงดันไฟฟ้า ประมาณ 90 องศา

เส้นแรงแม่เหล็กที่เกิดขึ้นจากขดลวดอาเมเจอร์ จะมีทิศทางเดียวกับเส้นแรงแม่เหล็กจากขั้วแม่เหล็ก ทำให้เส้นแรงแม่เหล็กเสริมกับ แรงเคลื่อนไฟฟ้าเหนี่ยวนำ จึงสูงขึ้น เมื่อต้องการให้แรงเคลื่อนไฟฟ้าคงที่ ต้องลดกระแสที่ขดลวดฟิลต์ให้ลดลง ดังรูปที่ 2.26

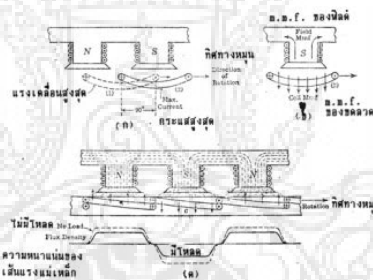

รูปที่ 2.26 แสดงการลดกระแสที่ขดลวดฟิลต์ทำให้แรงเคลื่อนไฟฟ้าเหนี่ยวนำคงที่

2.1.6 เวกเตอร์ไดอะแกรมของเครื่องกำเนิดไฟฟ้ากระแสสลับสามเฟสขณะมีโหลด

กำหนดให้

E_0 = แรงดันไฟฟ้าเหนี่ยวนำขณะไม่มีโหลด

E = แรงดันไฟฟ้าเหนี่ยวนำขณะมีโหลด

เป็นแรงดันเกิดขึ้นหลังจากการเกิดอาเมเจอร์รีแอกชันซึ่งค่าน้อยกว่า

E_0 เท่ากับ $I X_a$

V = แรงดันไฟฟ้าที่ขั้วสาย มีค่าน้อยกว่า E_0 เท่ากับ $I Z_s$ หรือน้อยกว่า

E อยู่ $I Z$ เมื่อ $Z_s = R_a + j(X_s)$

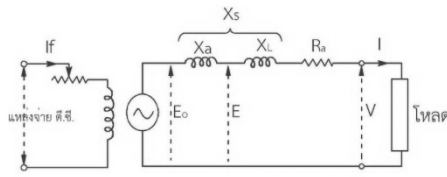

วงจรสมมูลของเครื่องกำเนิดไฟฟ้าขณะจ่ายโหลด

รูปที่ 2.27 วงจรสมมูลของเครื่องกำเนิดขณะมีโหลด

1. กรณีที่ โหลดมี P.F. เป็น 1

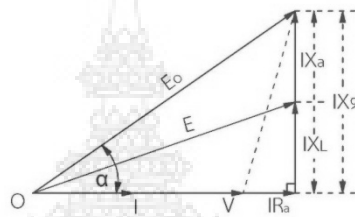

เวกเตอร์ไดอะแกรมของโหลดที่มี p.f. เป็นที่ 1

รูปที่ 2.28 เฟสเซอร์ไดอะแกรม กรณี P.F. เป็น 1

เมื่อเขียนเวกเตอร์ในรูปที่ 2.28 เป็นสมการเฟสเซอร์จะได้ว่า

$$E_0 = (V + IR_a) + j(IX_a + IX_1)$$

หาขนาดของสมการแพกเตอร์

$$E_0 = \sqrt{(V + IR_a)^2 + j^2(IX_a + IX_1)^2}$$

2. กรณีที่ โหลดมี P.F. เป็น Lagging

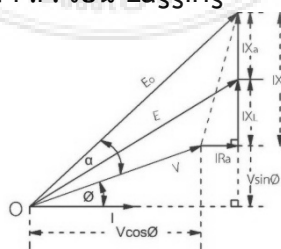

เวกเตอร์ไดอะแกรมของโหลดที่มี p.f. เป็นที่ lagging

รูปที่ 2.29 เฟสเซอร์ไดอะแกรม กรณี P.F. lagging

เมื่อเขียนเวกเตอร์ในรูปที่ 2.29 เป็นสมการเฟสเซอร์จะได้ว่า

$$E_0 = (V \cos \theta + IR_a) + j(V \sin \theta IX_a + IX_1)$$

หาขนาดของสมการแฟกเตอร์

$$E_0 = \sqrt{(V \cos \theta + IR_a)^2 + (V \sin \theta IX_a + IX_1)^2}$$

3. กรณีที่ โหลดมี P.F. เป็น Leading

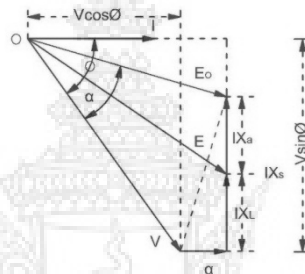

เวกเตอร์ไดอะแกรมของโหลดที่มี p.f. เป็นที่ leading

รูปที่ 2.30 เฟสเซอร์ไดอะแกรม กรณี P.F. leading

เมื่อเขียนเวกเตอร์ในรูปที่ 2.30 เป็นสมการเฟสเซอร์จะได้ว่า

$$E_0 = (V \cos \theta + IR_a) + j(-V \sin \theta IX_a + IX_1)$$

หาขนาดของสมการแฟกเตอร์

$$E_0 = \sqrt{(V \cos \theta + IR_a)^2 + (-V \sin \theta IX_a + IX_1)^2}$$

2.2 การควบคุมเครื่องกำเนิดไฟฟ้ากระแสสลับสามเฟส

ขณะที่เครื่องกำเนิดไฟฟ้ากระแสสลับทำงานนั้น โหลดจะมีการเปลี่ยนแปลงตลอดเวลา ทำให้แรงดันปลายสายเปลี่ยนแปลง ทำให้เกิดความเสียหายขึ้นกับโหลด ซึ่งโหลดอาจหยุดทำงานหรือเผาไหม้ ดังนั้นจึงต้องควบคุมแรงดันไฟฟ้าที่ป้อนให้กับโหลด ซึ่งปัจจุบันมีวิธีการควบคุมได้หลายวิธี สามารถแบ่งได้ 2 ประเภทใหญ่ ๆ คือ

2.2.1 การควบคุมแรงดันไฟฟ้าด้วยมือ

เป็นวิธีที่นิยมใช้กับ เครื่องกำเนิดไฟฟ้ากระแสสลับ 1 เฟสและมีกำลังเอาต์พุตไม่สูงนักการควบคุมโดยปรับเปลี่ยนความเร็วของตัวต้นกำลังให้น้อยลงหรือปรับกระแสไฟที่ป้อนขดลวดสนามแม่เหล็กให้น้อยลง แต่ข้อเสีย คือ ความแม่นยำน้อยและไม่รวดเร็ว

2.2.2 การควบคุมแรงดันไฟฟ้าด้วยระบบอัตโนมัติ

เป็นวิธีที่นิยมใช้กับเครื่องกำเนิดไฟฟ้าขนาดใหญ่ ที่มีกำลังเอาต์พุตสูง เช่น เครื่องกำเนิดไฟฟ้าในโรงไฟฟ้า เนื่องจากเมื่อโหลดเปลี่ยนแปลง กระแสโหลดและเพาเวอร์แฟกเตอร์ของโหลดจะเปลี่ยนแปลง ทำให้แรงดันไฟฟ้าปลายสายเปลี่ยนแปลง ดังนั้นจำเป็นต้องปรับเปลี่ยนแรงดันเพื่อ รักษาระดับให้คงที่ ตัวอย่างการควบคุมดังรูปที่ 2.31

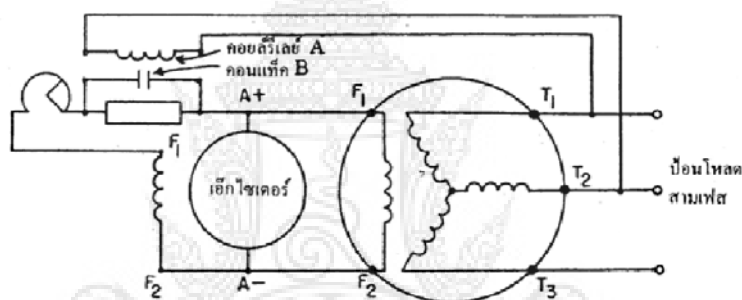

รูปที่ 2.31 ตัวอย่างรูปแบบการควบคุมแบบอัตโนมัติ

การทำงานในรูปที่ 2.31 ขณะที่เครื่องกำเนิดไฟฟ้าทำงานป้อนแรงดันให้กับโหลดขดลวดรีเลย์ A จะบังคับให้คอนแทก B เปิดและปิดหลายครั้ง ในเวลา 1 วินาที ทำให้เอ็กไซเตเตอร์ป้อนแรงดันและกระแสไฟตรงให้กับขดลวดสนามแม่เหล็กของเครื่องกำเนิดไฟฟ้า ด้วยขนาดคงที่ ถ้าแรงดันโหลดลดลง แรงดันที่รีเลย์ A จะลดลงด้วย ทำให้คอนแทก B ปิดแรงดันและกระแสไฟตรงจากเอ็กไซเตเตอร์ป้อนให้กับขดลวดสนามแม่เหล็กของเครื่องกำเนิด จะเพิ่มสูงขึ้น ทำให้แรงดันปลายสายที่ป้อนให้กับโหลดเพิ่มขึ้น แต่แรงดันที่ป้อนโหลดสูงขึ้นเท่าเดิม แรงดันที่รีเลย์ A จะสูงขึ้นด้วย ทำให้คอนแทก B สลับเปิดและปิดหลายครั้ง ทำให้ความต้านทานที่ต่อกับวงจรสูงขึ้น ทำให้แรงดันและกระแสที่เอ็กไซเตเตอร์ป้อนให้กับขดลวดสนามแม่เหล็กเครื่องกำเนิดลดลง ทำให้แรงดันปลายสายป้อนโหลดลดลงเท่าเดิม

ในปัจจุบันจะนิยมการควบคุมแรงดันแบบอัตโนมัติ ซึ่งมีความแม่นยำและรวดเร็ว ซึ่งมีการนำวงจรอิเล็กทรอนิกส์และคอมพิวเตอร์มาควบคุม ทำให้ความแม่นยำสูงขึ้น

2.2.3 โวลต์เตจเรกูเรชั่น

เมื่อโหลดเปลี่ยนแปลง แรงดันไฟฟ้าที่ขั้วเครื่องกำเนิดไฟฟ้าจะเปลี่ยนแปลงด้วย ไม่ได้ขึ้นกับกระแสของโหลดเพียงอย่างเดียว ยังขึ้นกับเพาเวอร์แฟกเตอร์ของโหลด การหาค่าโวลต์เตจเรกูเรชั่นเมื่อเครื่องกำเนิดจ่ายโหลดเต็มพิกัด (full-load) การคำนวณหาเปอร์เซ็นต์โวลต์เตจเรกูเรชั่นหาได้ดังนี้

$$\begin{aligned}\text{โวลต์เตจเรกูเรชั่น} &= \frac{(E_0 - V)}{V} \\ \% \text{ โวลต์เตจเรกูเรชั่น} &= \frac{(E_0 - V)}{V} \times 100\end{aligned}$$

เมื่อ

- E_0 = แรงเคลื่อนไฟฟ้าเหนี่ยวนำ
- = แรงดันไฟฟ้าที่ขั้วเมื่อไม่มีโหลด
- V = แรงดันไฟฟ้าที่ขั้วเมื่อมีโหลดเต็มพิกัด



รูปที่ 2.32 กระแสอาเมเจอร์ที่ P.F. ต่างๆ

เมื่อเครื่องกำเนิดจ่ายโหลดที่มีเพาเวอร์แฟกเตอร์นำหน้า แรงดันไฟฟ้าที่ขั้วจะสูงกว่าตอนไม่มีโหลด แต่เมื่อจ่ายโหลดมีค่าเพาเวอร์แฟกเตอร์ล้าหลังแรงดันไฟฟ้าที่ขั้วลดลงมากกว่าเมื่อโหลดมีค่าเพาเวอร์แฟกเตอร์เป็น 1 หรือ 100% ดังรูปที่ 2.32

2.2.4 การหาค่าของโวลต์เตจเรกูเรชั่น

ในกรณีเป็นเครื่องกำเนิดขนาดเล็ก การหาค่าโวลต์เตจเรกูเรชั่นสามารถหาได้โดยการต่อโหลดเข้าไปที่ขั้วของเครื่องกำเนิดโดยตรง ทำได้ดังนี้

ขับเครื่องกำเนิดไฟฟ้าให้หมุนด้วยความเร็วซิงโครนัส แล้วปรับแรงดันไฟฟ้าที่ขั้วให้ได้ค่าแรงดันเต็มพิกัด จากนั้นค่อย ๆ เพิ่มโหลดเข้าไป จนกระทั่งวัตต์มิเตอร์และแอมมิเตอร์

แสดงค่าเต็มพิกัดที่ค่าเพาเวอร์แฟกเตอร์ตามต้องการหลังจากนั้นจึงปลดโพลดออกทั้งหมด แล้วอ่านค่าแรงดันไฟฟ้าที่ขั้วจากโวลต์มิเตอร์จะเป็นค่าแรงดันไฟฟ้าที่ขั้วเมื่อไม่มีโพลด

$$\text{โวลต์เตจเรกูเรชั่น} = \frac{(E_0 - V)}{V} \times 100$$

ในกรณีเครื่องกำเนิดไฟฟ้าขนาดใหญ่การหาค่าโวลต์เตจเรกูเรชั่น ด้วยวิธีดังนี้

2.2.4.1 วิธีซิงโครนัสอิมพีแดนซ์

ลำดับขั้นตอนทดสอบมีดังนี้

- วัดและคำนวณหาค่าความต้านทานของขดลวดอาเมเจอร์แต่ละเฟส ด้วย ดี.ซี. โวลต์มิเตอร์และ ดี.ซี. แอมป์มิเตอร์ แล้วนำมาคำนวณหาค่า R_a จากสมการ

$$R_a \text{ (effective armature resistance)} = 1.5R_{dc}$$

หรือจะใช้ไฟฟ้ากระแสสลับป้อนเข้าไปในขดลวดอาเมเจอร์แต่ละเฟส แล้ววัดกระแสและวัดกำลังไฟฟ้าที่ป้อนให้โพลดขดลวด คำนวณจากสมการ

$$R_a \text{ (effective armature resistance)} = \frac{P}{I_2^2}$$

- ค่าซิงโครนัสอิมพีแดนซ์ (ZS) หาได้จากการทดสอบในสภาวะวงจรเปิดและการทดสอบในสภาวะลัดวงจร

2.1 ทดสอบในสภาวะวงจรเปิด

- ต่อขดลวดสนามแม่เหล็ก ของเครื่องกำเนิดเข้ากับแหล่งจ่ายไฟตรงโดยผ่านดี.ซี. แอมป์มิเตอร์ และรีโอสตาท
- ต่อ เอ.ซี. โวลต์มิเตอร์ระหว่างปลายสายขดลวดอาเมเจอร์คู่หนึ่งดังรูปที่ 2.33.

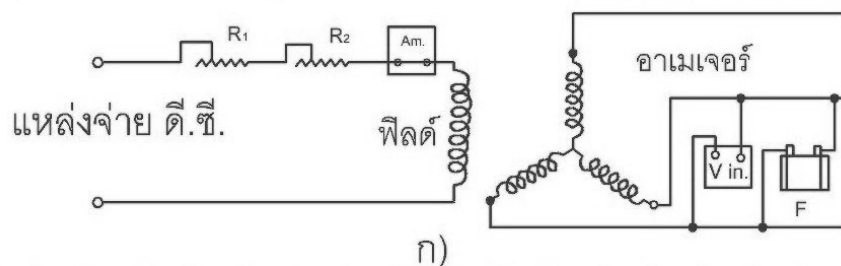

รูปที่ 2.33 วิธีซิงโครนัสอิมพีแดนซ์ในสภาวะวงจรเปิด

3. ขับเครื่องกำเนิดให้หมุนด้วยความเร็วเต็มพิกัด หรือความเร็วซิงโครนัส
4. บันทึกค่า I_f และ E_0 ที่เกิดขึ้น โดยปรับค่ากระแสฟิลด์ จาก $I_f = 0$ จนกระทั่ง E_0 มีค่าประมาณ 1.5 เท่าของแรงดันต้นเต็มพิกัด
5. เขียนกราฟแสดงความสัมพันธ์ระหว่างแรงเคลื่อนไฟฟ้ากับกระแสฟิลด์

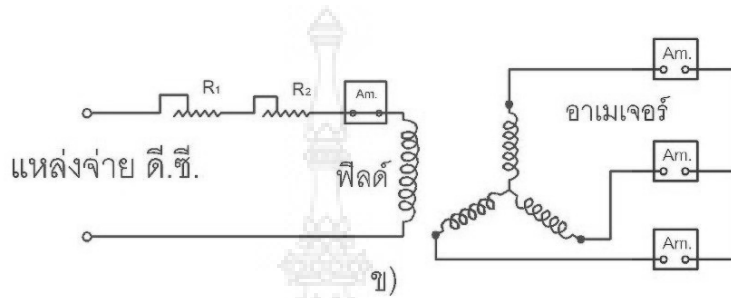

รูปที่ 2.34 วิธีซิงโครนัสอิมพีแดนซ์ในสภาวะวงจรถัด

2.2 การทดสอบในสภาวะวงจรถัด

1. ต่อ เอ.ซี.แอมมิเตอร์อนุกรมกับขดลวดอามมิเตอร์แต่ละเฟสแล้วตั้งรูป 2.34
2. ขับเครื่องกำเนิดให้หมุนด้วยความเร็วเต็มพิกัด
3. ปรับ $I_f = 0$ จนกระทั่งกระแสลัดวงจร I_{sc} มีค่าประมาณ 1.5 เท่าของกระแสเต็มพิกัด
4. บันทึกค่า I_f และ I_{scc} แล้วนำไปเขียนกราฟความสัมพันธ์ระหว่าง I_f และ I_{scc} ดังรูป 2.34.

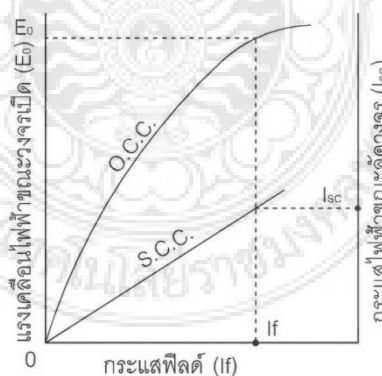

รูปที่ 2.35 กราฟความสัมพันธ์ระหว่าง I_f กับ I_{scc}

การหาค่าทำได้ดังนี้

$$E_0 = I_{scc} Z_s$$

$$Z_s = \frac{E_{0(\text{occ})}}{I_{sc(\text{scc})}}$$

$$X_a = \sqrt{(Z_a)_2 - (R_a)_2}$$

เมื่อทราบค่า R_a และ X_a ของเครื่องกำเนิดไฟฟ้า สามารถหาค่า E_0 เมื่อโหลดมีค่า เพาเวอร์แฟกเตอร์ต่าง เช่น โหลดมีเพาเวอร์แฟกเตอร์ล่าช้าหาค่า E_0

$$E_0 = (V \cos \theta + IR_a) + j(V \sin \theta + IX_a)$$

$$\text{โวลต์เตจเรกูเรชัน} = \frac{(E_0 - V)}{V} \times 100$$

2.3 การขนานเครื่องกำเนิดไฟฟ้ากระแสสลับสามเฟสเข้าสู่ระบบ

เครื่องกำเนิดไฟฟ้าสามารถนำมาขนานกับเครื่องกำเนิดไฟฟ้าหรือกับโพลวงได้ แต่ก่อนที่แหล่งกำเนิดไฟฟ้าสองแหล่งจะขนานกันได้นั้น ชุดควบคุมการขนานจะต้องเช็ค โวลต์ ความถี่ และ Phase Shift ให้ตรงกันก่อน ซึ่งเงื่อนไขสำคัญในการขนานเครื่องกำเนิดไฟฟ้าเข้ากับระบบ คือ

1. แรงดันไฟฟ้าที่ขั้วของเครื่องกำเนิดไฟฟ้าและที่ระบบที่ขนานเข้าไปต้องมีขนาดเท่ากันหรือใกล้เคียงกัน
2. ความถี่ของแรงเคลื่อนไฟฟ้าของเครื่องกำเนิดไฟฟ้าและที่ระบบที่ขนานเข้าไปต้องมีค่าเท่ากัน
3. มุมเฟสจะต้องตรงกัน (In-Phase)

โดยจะต้องทำการขนานที่ตำแหน่ง Zero Crossing ซึ่งเป็นตำแหน่งที่เกิดความปลอดภัยสูงสุดในการขนานเครื่องกำเนิดไฟฟ้าเข้าระบบ ซึ่งในปัจจุบันได้มีการพัฒนาเอาไมโครคอนโทรลเลอร์มาใช้ในการควบคุมเครื่องกำเนิดไฟฟ้าทำให้สามารถทำงานได้ง่ายมากขึ้นและมีประสิทธิภาพมากขึ้น อีกทั้งยังสามารถวัดค่าได้ในตัว



รูปที่ 2.36 อุปกรณ์ควบคุมและเครื่องกำเนิดไฟฟ้า

ส่วนลักษณะของการ Sync นั้น โดยทั่วไปมักจะเรียกว่า Sync ขาไป กับ Sync ขากลับ โดยปกติเครื่องกำเนิดไฟฟ้ามักจะทำงานอัตโนมัติ ซึ่งโดยปกติจะใช้เวลาประมาณ 15 วินาที หลังจากไฟฟ้าระบบหลักหายไประบบจะจ่ายไฟเข้าสู่ระบบได้ (ซึ่งเวลาดังกล่าวสามารถปรับตั้งได้) เพื่อเป็นการป้องกันการสตาร์ทเครื่องกำเนิดไฟฟ้าแบบไม่จำเป็น เพราะบางเวลาระบบไฟฟ้าหลักอาจเกิดการ Brown Out และกลับคืนมาได้ในเวลาสั้น ๆ และหลังจากที่ระบบไฟฟ้าหลักกลับคืนมาในระหว่างที่ Transfer จากเครื่องกำเนิดไฟฟ้าไประบบไฟฟ้าหลัก เครื่องกำเนิดไฟฟ้าก็จะเดินเครื่อง Cool Down ไปอีกประมาณ 5 นาที (เวลา Cool Down สามารถปรับได้เช่นกัน) แล้วเครื่องกำเนิดไฟฟ้าก็จะดับเองโดยอัตโนมัติ

การขนานเครื่องกำเนิดไฟฟ้ามี 2 ขั้นตอนด้วยกันคือ

1. Sync ขาไป

Sync ขาไป คือ สถานการณ์ที่ทราบแล้วว่าไฟหลวงจะดับ ดังนั้นจึงสั่งสตาร์ทเครื่องกำเนิดไฟฟ้าแล้วนำไฟจากเครื่องกำเนิดไฟฟ้าขนานเข้ากับไฟหลวงก่อนที่ไฟจะดับ ซึ่งเมื่อไฟหลวงดับไปแล้วแต่ก็ยังมีไฟจากเจนคอยจ่ายให้กับโหลดอยู่นั่นเอง (สังเกตว่าลักษณะการทำงานเช่นนี้จะไม่มีการขาดหายไปเลย) หรืออาจจะเป็นลักษณะของการขนานเครื่องกำเนิดไฟฟ้าหลาย ๆ เครื่องเข้าด้วยกันก่อนแล้วขนานกับไฟหลวงอีกทีก็ได้ ตัวอย่างการใช้งานเช่นนี้พบได้มากในยุคที่ราคาของน้ำมันดีเซลยังราคาถูก ก็จะได้เดินเครื่องกำเนิดไฟฟ้าจ่ายไฟให้กับโหลดเพื่อตัด Peak ของการไฟฟ้า แต่ในปัจจุบันราคาน้ำมันดีเซลสูงเกินกว่าที่จะเดินเครื่องเพื่อตัด Peak แล้ว

2. Sync ขากลับ

Sync ขากลับ คือ สถานการณ์ที่ไฟดับไปแล้ว และใช้เครื่องกำเนิดไฟฟ้าจ่ายไฟให้กับโหลดอยู่ และหลังจากที่ไฟหลวงกลับมาจะนำไฟหลวงมาขนานเข้ากับไฟจากเครื่องกำเนิดไฟฟ้าก่อน แล้วจึงค่อยปลดไฟจากเครื่องกำเนิดไฟฟ้าออก (สังเกตว่าลักษณะเช่นนี้ก็จะไม่มีไฟขาดหายไปเช่นกัน)

บทที่ 3

การออกแบบและการประกอบสร้าง

ในบทนี้จะกล่าวถึงการออกแบบและประกอบสร้างชุดจำลองการควบคุมเครื่องกำเนิดไฟฟ้ากระแสสลับ 3 เฟส โดยเนื้อหาจะแบ่งออกเป็น 4 ส่วนด้วยกัน ส่วนที่ 1 คือเงื่อนไขในการออกแบบชุดจำลองการควบคุมเครื่องกำเนิดไฟฟ้ากระแสสลับสามเฟส ส่วนที่ 2 เครื่องกำเนิดไฟฟ้าในส่วนนี้จะ เป็นรายละเอียดของเครื่องกำเนิดไฟฟ้าและเครื่องต้นกำลังที่เลือกมาใช้รวมถึงรูปแบบในการประกอบสร้างชุดเครื่องกำเนิดไฟฟ้ากระแสสลับสามเฟส ส่วนที่ 3 เป็นชุดควบคุมเครื่องกำเนิดไฟฟ้ากล่าวถึง ไมโครคอนโทรลเลอร์ (RGK 700) ที่นำมาใช้การควบคุมรวมถึงการออกแบบวงจรการควบคุมเครื่องกำเนิดไฟฟ้า และสุดท้ายส่วนที่ 4 คือ ของชุดจำลองภาระทางไฟฟ้ากล่าวถึงอุปกรณ์ที่เลือกใช้เป็นภาระทางไฟฟ้าของเครื่องกำเนิดไฟฟ้ายรวมถึงรูปแบบการต่อวงจรของภาระทางไฟฟ้า

3.1 เงื่อนไขในการออกแบบชุดจำลองการควบคุมเครื่องกำเนิดไฟฟ้า

เนื่องจากในปัจจุบันการควบคุมเครื่องกำเนิดไฟฟ้ามีการพัฒนารูปแบบของการควบคุม รวมถึงอุปกรณ์ที่ใช้ในการควบคุม มีการนำเอาไมโครคอนโทรลเลอร์มาใช้ในการควบคุมแทนอุปกรณ์เดิมทำให้การทำงานมีประสิทธิภาพและมีความแม่นยำมากขึ้น ซึ่งในปัจจุบันการนำเอา ไมโครคอนโทรลเลอร์มาใช้ในการทดลองในการศึกษาเครื่องกำเนิดไฟฟ้านั้นยังไม่แพร่หลายมากนัก จึงได้พัฒนาชุดจำลองนี้ขึ้นเพื่อสร้างชุดจำลองที่สามารถใช้ศึกษาเครื่องกำเนิดไฟฟ้าที่มีเทคโนโลยีทันสมัยตรงกับรูปแบบการควบคุมที่ใช้ในปัจจุบัน โดยการออกแบบนั้นจะต้องตอบคำถามของโครงการในครั้งนี้ได้ คำถามของโครงนี้มีด้วยกันทั้งหมด 3 ข้อ คือ

1. ค่าพารามิเตอร์ที่เกี่ยวข้องกับการควบคุมเครื่องกำเนิดไฟฟ้าในขณะไม่จ่ายโหลดมีอะไรบ้าง มีลักษณะ และมีความแตกต่างระหว่างเครื่องกำเนิดไฟฟ้าและระบบหลักอย่างไร
2. ค่าพารามิเตอร์ที่เกี่ยวข้องกับการควบคุมเครื่องกำเนิดไฟฟ้าในขณะจ่ายโหลดมีอะไรบ้าง มีลักษณะ และมีความแตกต่างระหว่างเครื่องกำเนิดไฟฟ้าและระบบหลักอย่างไร
3. หลักการในการขนานเครื่องกำเนิดไฟฟ้าเข้าระบบเพื่อทดแทนระบบหลักเมื่อเกิดความผิดพลาดมีหลักและวิธีการอย่างไร เมื่อเครื่องกำเนิดจ่ายโหลดแล้วมีความแตกต่างกับระบบไฟหลักหรือไม่

3.2 การออกแบบและประกอบสร้างเครื่องกำเนิดไฟฟ้า

1. เครื่องกำเนิดไฟฟ้ากระแสสลับสามเฟส

เนื่องจากการจำลองการควบคุมเครื่องกำเนิดไฟฟ้าสำหรับการทดลอง จึงได้เลือกเอาเครื่องกำเนิดไฟฟ้ากระแสสลับ 3 เฟส โดยเลือกใช้เครื่องกำเนิดที่มีขนาดพอเหมาะกับการทดลองไม่จำเป็นต้องใช้เครื่องกำเนิดที่มีกำลังไฟฟ้าสูงมาก จากการสำรวจขนาดที่มีการซื้อขายกันทั่วไปพบว่า เครื่องกำเนิดไฟฟ้ากระแสสลับ 3 เฟส มีขนาดในการจ่ายกำลังต่ำสุดที่ 10 กิโลวัตต์ จึงได้เลือกเอาเครื่องกำเนิดขนาด 10 กิโลวัตต์ มาใช้ในโครงการนี้

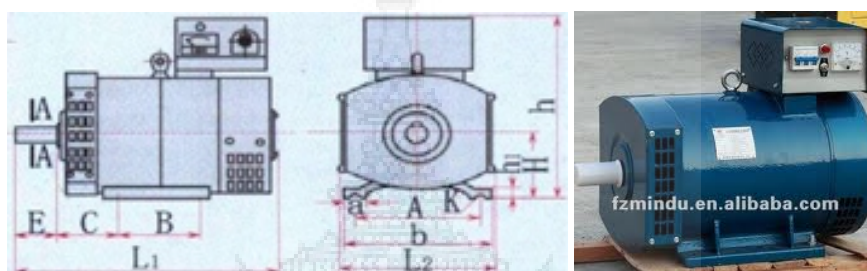

รูปที่ 3.1 เครื่องกำเนิดไฟฟ้ากระแสสลับ
380 โวลต์กระแสสลับ 3 เฟส ขนาด 10 กิโลวัตต์

2. เครื่องต้นกำลัง

ชุดต้นกำลังที่จะมาใช้กับเครื่องกำเนิดไฟฟ้า เลือกเครื่องต้นกำลังที่เป็นเครื่องยนต์ เพราะสามารถหาได้ง่าย มีราคาถูก และเหมาะกับการนำมาใช้กับชุดจำลองเพื่อทำการทดลอง การเลือกขนาดของเครื่องยนต์ให้เหมาะสมกับขนาดของเครื่องกำเนิดไฟฟ้านั้น ต้องเลือกเครื่องยนต์ที่สามารถทำความเร็วสัมพันธ์กันกับความเร็วที่เครื่องกำเนิดต้องการ จึงจะทำให้เครื่องกำเนิดไฟฟ้าทำงานได้ตามข้อมูลจำเพาะของเครื่องกำเนิด



รูปที่ 3.2 เครื่องยนต์ 4 จังหวะ ขนาด 9 แรงม้า

จากรูปที่ 3.2 เป็นเครื่องยนต์ 4 จังหวะ ขนาด 9 แรงม้า ซึ่งสามารถทำความเร็วรอบได้ตามที่เครื่องกำเนิดไฟฟ้าต้องการ ซึ่งเป็นเครื่องต้นกำลังที่ทำให้เครื่องกำเนิดสามารถทำงานได้อย่างเต็มประสิทธิภาพ โดยข้อมูลจำเพาะของเครื่องกำเนิดไฟฟ้าและเครื่องยนต์ มีดังนี้

ข้อมูลจำเพาะของเครื่องกำเนิดไฟฟ้า

ตารางที่ 3.1 ข้อมูลจำเพาะของเครื่องกำเนิดไฟฟ้ากระแสสลับสามเฟส STC-10

ข้อมูลจำเพาะของเครื่องกำเนิดไฟฟ้า		ข้อมูลจำเพาะของเครื่องกำเนิดไฟฟ้า	
ขนาดกำลังไฟฟ้า	10 kW (12.5 kVA)	อัตรารอบในการทำงาน	1500 rpm
แรงดันไฟฟ้า (line-line)	380 VAC	เพาเวอร์แฟคเตอร์	0.8
ขนาดกระแสที่จ่ายได้	19.1 A	แรงดันกระตุ้น	100 V
ความถี่	50 Hz	กระแสกระตุ้น	4.6 A
ระบบ	3 phase	จำนวนขั้วแม่เหล็ก	4 pole

ข้อมูลจำเพาะของเครื่องยนต์

ตารางที่ 3.2 ข้อมูลจำเพาะของเครื่องยนต์ 4 จังหวะ ขนาด 9 แรงม้า

ข้อมูลจำเพาะของเครื่องยนต์		ข้อมูลจำเพาะของเครื่องยนต์	
แบบเครื่องยนต์	4 stroke Single cylinder	ชนิดน้ำมันหล่อลื่น	15w/SAE 40
แรงม้าสูงสุด	5.1KW/3000 rpm	ระยะเขี้ยวหัวเทียน	0.6-0.8 mm
แรงบิดสูงสุด	33.2 N	ระบบจุดระเบิด	ชุดคอยล์ไฟ จุดระเบิด
ความเร็วรอบเดินเบา	1350 rpm	ระบบกรองอากาศ	แบบแห้งและแบบเติมมันเครื่อง
อัตราการสวิงของรอบเครื่อง	10%	การหมุนเครื่องยนต์	หมุนตามเข็มนาฬิกา
ความกว้างกระบอกสูบ	73 mm	ระบบสตาร์ท	Recoil Start
ระยะชักกระบอกสูบ	58 mm	ขนาด กว้างxยาวxสูง	380x530x410
ปริมาตรกระบอกสูบ	270 cc	น้ำหนัก	29 kg
อัตราส่วนกำลังอัด	8.2:1		

3. โครงหรือฐานยึดเครื่องกำเนิดไฟฟ้ากับเครื่องต้นกำลัง

โครงหรือฐานของเครื่องกำเนิดถูกออกแบบมาเพื่อรองรับเครื่องกำเนิดไฟฟ้ากับเครื่องต้นกำลัง โดยให้ทั้งสองสามารถทำงานสัมพันธ์กันได้ และต้องมีความแข็งแรงทนทานเมื่อเครื่องกำเนิดและเครื่องต้นกำลังทำงาน และสามารถเคลื่อนย้ายได้ง่าย

4. การประกอบสร้างชุดเครื่องกำเนิดไฟฟ้า

การประกอบสร้าง ใช้พู่เล่และสายพานเป็นตัวกลางในการส่งพลังงานทางกลระหว่างเครื่องต้นกำลังไปยังเครื่องกำเนิดไฟฟ้า เนื่องจากมีราคาถูก สามารถหามาทดแทนได้ง่ายหากเกิดการเสียหาย และง่ายต่อการบำรุงรักษา



รูปที่ 3.3 เป็นชุดเครื่องกำเนิดไฟฟ้ากระแสสลับที่ได้จากการออกแบบและประกอบสร้าง

3.3 การออกแบบและประกอบสร้างชุดควบคุมเครื่องกำเนิดไฟฟ้า

1. เครื่องควบคุมเครื่องกำเนิดไฟฟ้า (RGK 700)

เนื่องจากในปัจจุบันการควบคุมเครื่องกำเนิดไฟฟ้ามีการพัฒนาเอาไมโครคอนโทรลเลอร์มาใช้ทดแทนการควบคุมด้วยวิธีการเดิม เพราะไมโครคอนโทรลเลอร์มีประสิทธิภาพในการทำงานสูง สามารถทำงานแบบอัตโนมัติได้ และในขณะเดียวกันยังสามารถวัดค่าพารามิเตอร์ต่าง ๆ ของระบบได้ภายในตัวเอง ทำให้ระบบสามารถศึกษาและทำความเข้าใจได้ง่าย อีกทั้งยังมีความถูกต้องแม่นยำสูงในการวัดค่า เนื่องจากการวัดแบบดิจิทัลซึ่งแม่นยำกว่าระบบอนาล็อกแบบเดิม

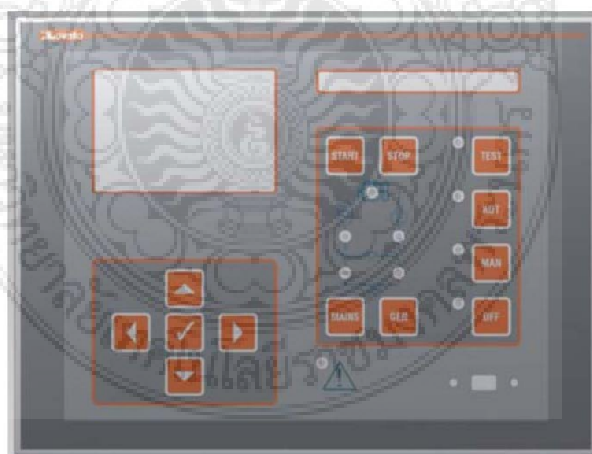

รูปที่ 3.4 Generator Controller (RGK 700)

จากรูปที่ 3.4 เป็น เครื่องควบคุมเครื่องกำเนิดไฟฟ้า (RGK 700) ที่เลือกนำมาใช้ในชุดจำลองการควบคุมเครื่องกำเนิดไฟฟ้า (เป็นการสนับสนุนทางด้านอุปกรณ์และความรู้ทางด้านเทคนิคจาก บริษัท คอมโพลแม็ค จำกัด) RGK 700 มีความสามารถในการทำงานที่ครอบคลุม สามารถ

ควบคุมการทำงานของเครื่องกำเนิดได้ทั้ง การเริ่มเดินเครื่อง หยุดเดินเครื่องกำเนิดไฟฟ้า และขนานเครื่องกำเนิดไฟฟ้า โดยอัตโนมัติ สามารถควบคุมด้วยมือเพื่อเลือกให้รับไฟจากระบบหลักหรือรับไฟจากเครื่องกำเนิดไฟฟ้า มีโหมดการทดสอบระบบ และยังสามารถวัดค่าการทำงานของระบบเป็นแบบดิจิทัล โดยค่าที่ RGK 700 สามารถวัดได้ ดังที่แสดงในรูปต่อไปนี้

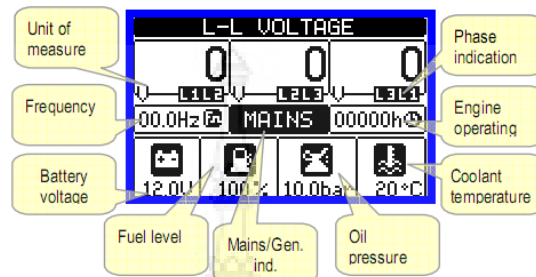

รูปที่ 3.5 การวัดค่า แรงดันระหว่างสาย ของ RGK 700

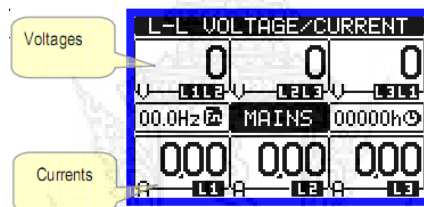

รูปที่ 3.6 การวัดค่า แรงดันระหว่างสาย / กระแสแต่ละเฟส ของ RGK 700

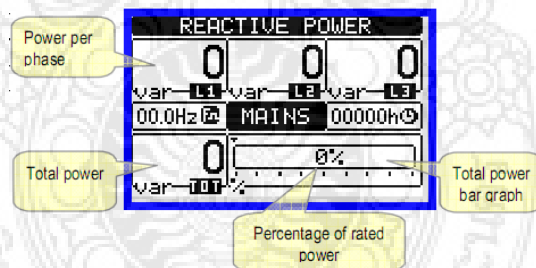

รูปที่ 3.7 การวัดค่า กำลังไฟฟ้าต้านกลับ ของ RGK 700

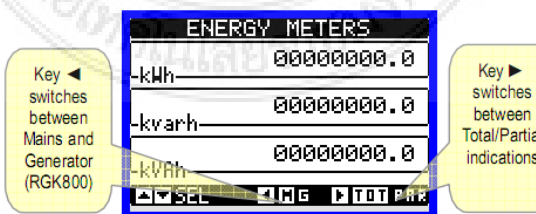

รูปที่ 3.8 การวัดค่า พลังงาน ของ RGK 700

MAINS	L1	L2	L3
V L-L	0	0	0
V L-N	0.00	0.00	0.00
W	0	0	0
Var	0	0	0
VA	0	0	0
PF	0.00	0.00	0.00

Annotations: Mains/Gen. Ind., Phase indication, Measurements indication, Measurement values.

รูปที่ 3.9 การเปรียบเทียบค่าพารามิเตอร์แต่ละเฟสของ RGK 700

FUEL STATUS	
Current level bar	100%
Total tank capacity	CAPACITY... (lit): 1000
Available fuel	FUEL LEFT... : 1000
Quantity after filling	TANK FILL... : 0
Filling pump state	TOPPING-UP FUEL:
Man. pump command	[SEL]

รูปที่ 3.10 การแสดงสถานะเชื้อเพลิงของ RGK 700

ENGINE OPERATION	
Total engine work hours	ENGINE HOURS: 00000:43
Part. engine work hours	PAR EN. HOURS: 00000:43
Load supplied hours	LOAD HOURS... : 00000:00
Attempted starts counter	TOTAL STARTS... : 0352
Percentage successful attempts	OK STARTS... : 3.1%
Load switching counter	LOAD SWITCH... : 5360

รูปที่ 3.11 การแสดงสถานะการทำงานของเครื่องยนต์ผ่าน RGK 700

INPUT/OUTPUT STATUS			
INP01	INP09	OUT01	OUT09
INP02	INP10	OUT02	OUT10
INP03	INP11	OUT03	OUT11
INP04	INP12	OUT04	OUT12
INP05	INP13	OUT05	OUT13
INP06	INP14	OUT06	OUT14
INP07	INP15	OUT07	OUT15
INP08	INP16	OUT08	OUT16

Annotation: Digital I/O state In reverse = enabled

รูปที่ 3.12 การแสดงสถานะเอาต์พุตของ RGK 700

จากรูปที่ 3.5 - 3.12 เป็นการแสดงค่าพารามิเตอร์ต่าง ๆ ที่ RGK 700 สามารถวัดและแสดงค่าได้ นอกจากนี้ RGK 700 ยังมีเทอร์มินอลเอาต์พุตที่ใช้ต่อร่วมกับอุปกรณ์ควบคุมการทำงาน อุปกรณ์เซนเซอร์ ที่จำเป็นในการทำงานของระบบไฟหลักและเครื่องกำเนิดไฟฟ้า

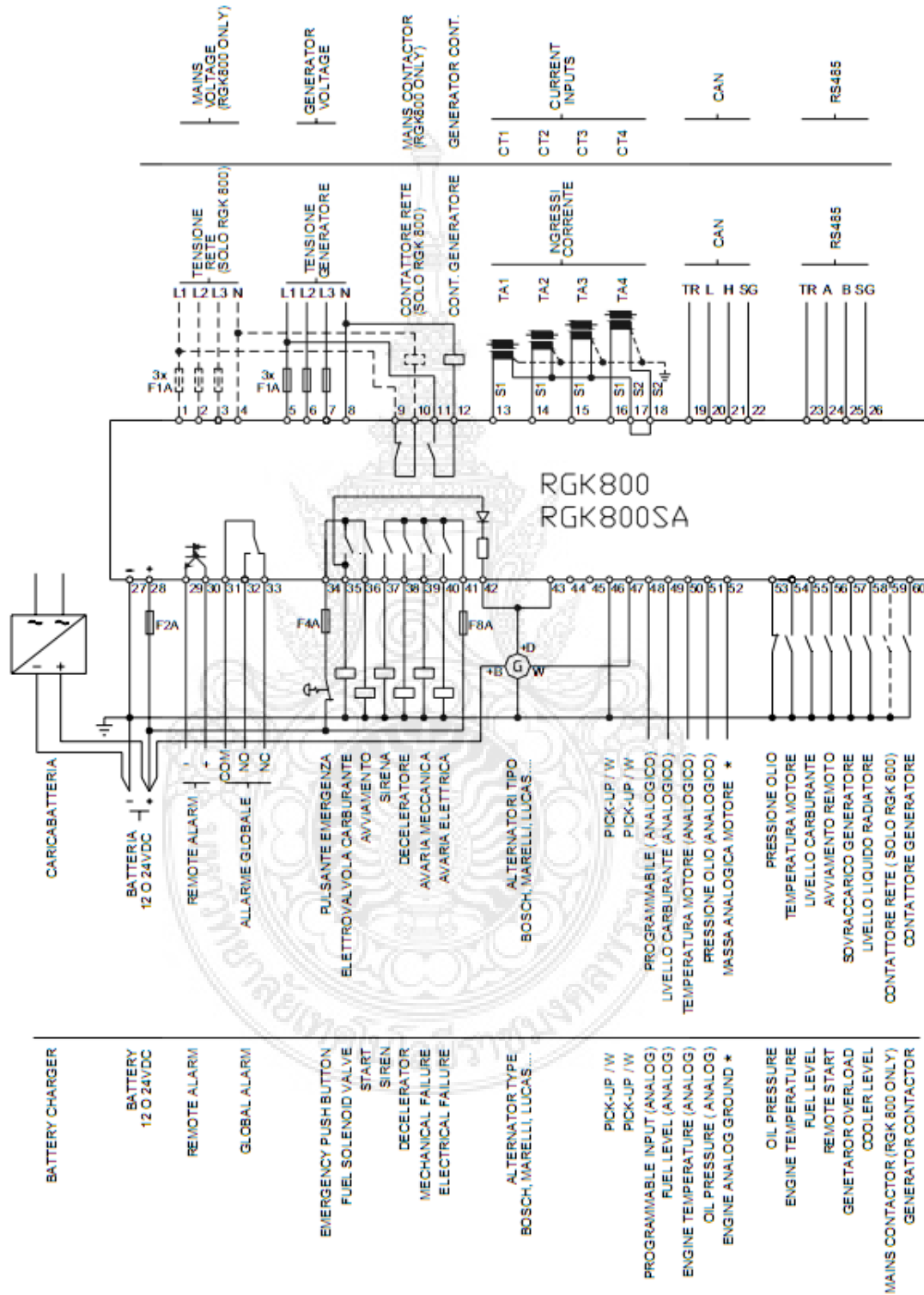

รูปที่ 3.13 ไดอะแกรมการต่อเอาต์พุตและอุปกรณ์ที่สามารถต่อรวมได้กับ RGK 700

2. ตู้โลหะสำหรับประกอบชุดควบคุมเครื่องกำเนิดไฟฟ้า

เป็นตู้โลหะที่สั่งทำขึ้นเพื่อประกอบชุดควบคุมเครื่องกำเนิดไฟฟ้า ภายในแบ่งออกเป็นสองชั้น สำหรับชุดควบคุมเครื่องกำเนิด และ ชุดจำลองภาระทางไฟฟ้า เพื่อสะดวกในการขนย้าย และสะดวกต่อการทดลอง รายละเอียดของตู้โลหะแสดงในรูปที่ 3.14

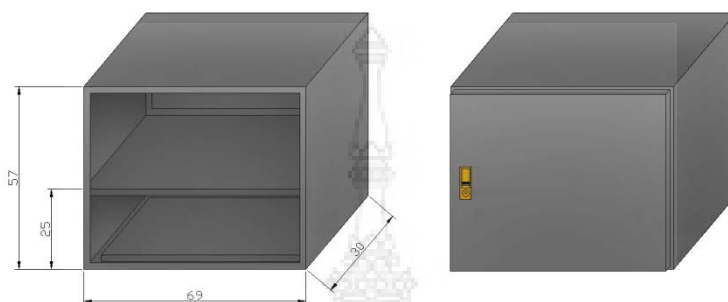

รูปที่ 3.14 แบบของตู้โลหะที่ทำการออกแบบ



รูปที่ 3.15 ที่ ตู้โลหะจริงจากการประกอบสร้าง

3. การประกอบสร้างชุดควบคุมเครื่องกำเนิดไฟฟ้า

การประกอบสร้างชุดควบคุมเครื่องกำเนิดไฟฟ้า ทำการประกอบสร้างที่ด้านบนของตู้ควบคุม นอกเหนือจาก RGK 700 แล้วยังมีอุปกรณ์อินพุตและเอาต์พุต ที่แสดงสถานะของระบบในการควบคุมเครื่องกำเนิดไฟฟ้าในขั้นต้นที่อยู่ในส่วนของระบบไฟฟ้า และอุปกรณ์ที่นำมาใช้จะต้องมี แรงดัน ที่ตรงกันกับช่องอินพุตหรือเอาต์พุตนั้น ๆ เพื่อไม่ให้เกิดความเสียหายขึ้นกับ RGK 700 ไดอะแกรมการต่อวงจรของระบบควบคุมเครื่องกำเนิดไฟฟ้ารวมทั้งอุปกรณ์ แสดงในรูปที่ 3.16

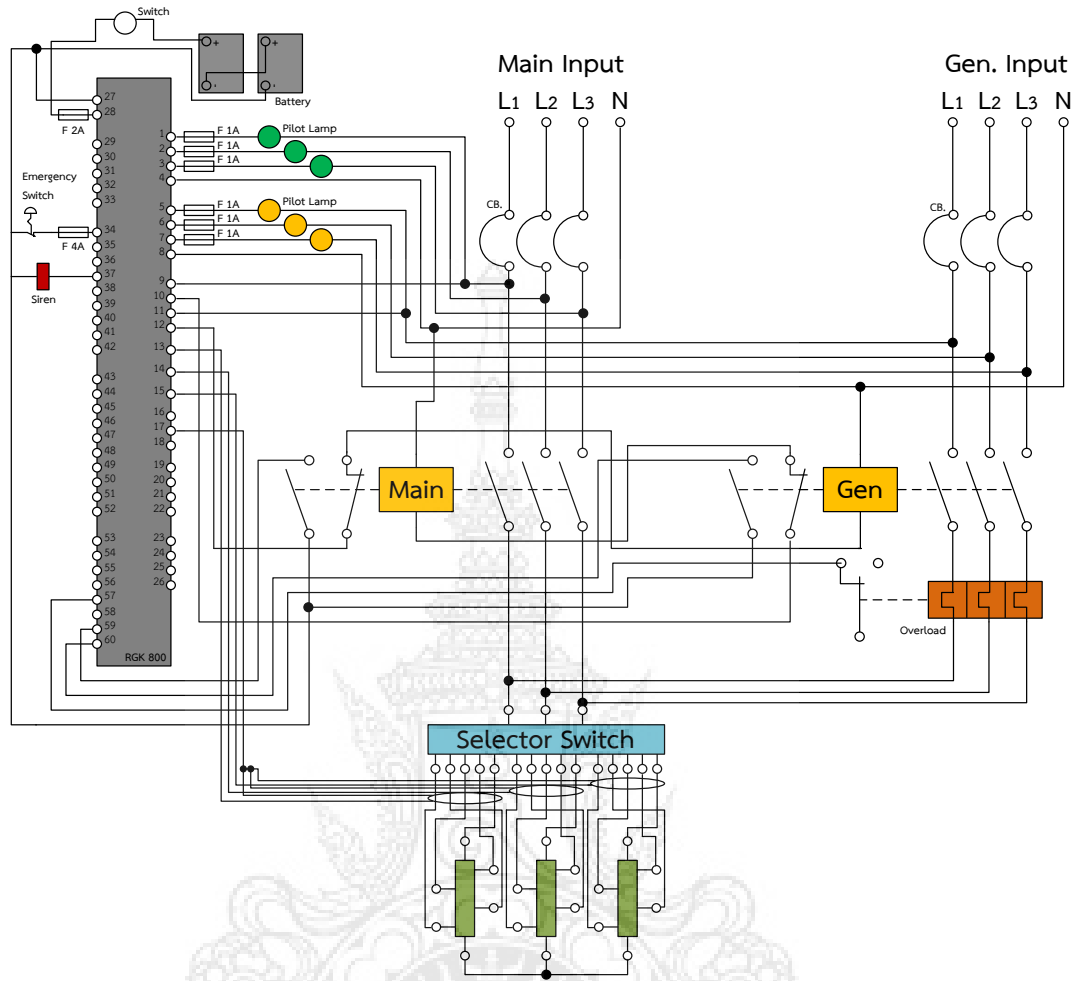

รูปที่ 3.16 ไดอะแกรมวงจรของชุดควบคุมเครื่องกำเนิด

3.4. การออกแบบและประกอบสร้างชุดจำลองภาระทางไฟฟ้า

จากความต้องการในการศึกษาคุณลักษณะของเครื่องกำเนิดไฟฟ้า จำเป็นจะต้องมีการปรับเพิ่มขึ้นหรือลดลงได้ จึงได้ทำการออกแบบภาระทางไฟฟ้าที่สามารถปรับระดับได้ โดยสามารถปรับระดับได้ 5 ระดับ เพื่อให้สามารถวิเคราะห์คุณลักษณะและพฤติกรรมของเครื่องกำเนิดไฟฟ้า เมื่อเกิดการเปลี่ยนแปลงของภาระทางไฟฟ้าได้ อุปกรณ์ที่ใช้ในชุดจำลองภาระทางไฟฟ้า มีดังนี้

1. ตัวต้านทานปรับค่าแบบแท็บ

ในการจำลองภาระทางไฟฟ้าชุดจำลองนี้ เลือกเอาตัวต้านทานปรับค่าแบบแท็บมาใช้เนื่องจากสามารถปรับระดับของค่าความต้านทานได้ตามแท็บของตัวต้านทาน เพราะว่าการทดลองจำเป็นที่จะต้องมีการเพิ่มหรือลดภาระทางไฟฟ้า ให้สามารถวิเคราะห์คุณลักษณะหรือพฤติกรรมของเครื่องกำเนิดได้ตัวต้านทานปรับค่าแบบแท็บที่ใช้ในชุดจำลองนี้เป็น ตัวต้านทานปรับค่าแบบแท็บ 1000วัตต์ 1000โอห์ม จำนวน 3 ตัว ต่อกันแบบ สตาร์



รูปที่ 3.17 ตัวต้านทานปรับค่าแบบแท็บ 1000วัตต์ 1000โอห์ม

2. ซีเลคเตอร์สวิตช์

ซีเลคเตอร์สวิตช์เป็นอุปกรณ์ที่สามารถเลือกตำแหน่งของวงจรต่าง ๆ แล้วแต่การนำไปประยุกต์ใช้ในวงจรนั้น โดยซีเลคเตอร์สวิตช์ที่ใช้ในการสร้างชุดจำลองภาระทางไฟฟ้าได้ใช้ ซีเลคเตอร์สวิตช์ 5 ระดับ 3 ขั้ว เพราะวงจรภายในของซีเลคเตอร์สวิตช์เองสามารถนำมาใช้ในการออกแบบได้อย่างเหมาะสม ดังแสดงในรูปที่ 3.18.

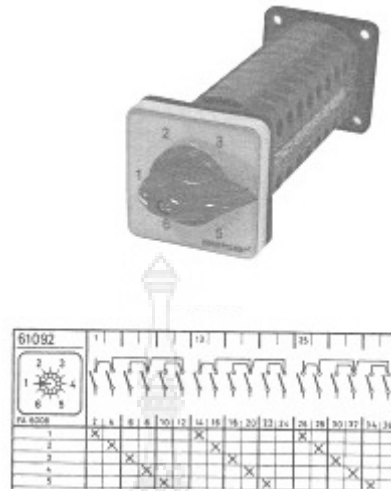

รูปที่ 3.18 ซีเลคเตอร์สวิตช์ 5 ระดับ 3 ขั้ว

3. การประกอบสร้างชุดจำลองภาระทางไฟฟ้า

การประกอบสร้างชุดจำลองภาระทางไฟฟ้าต้องการให้สามารถปรับระดับเพิ่มหรือลดลงได้โดยกำหนดให้ปรับได้ 5 ระดับ โดยแบ่งจากโหลดทั้งหมด 100% ให้ปรับเพิ่มระดับในแต่ละระดับเป็น 20% จาก 0% ขึ้นไปเรื่อยๆ จนถึงเต็ม 100% เพื่อศึกษาผลจากการเพิ่มหรือลดลงของภาระทางไฟฟ้าส่งผลอย่างไรต่อระบบบ้าง โดยชุดจำลองภาระทางไฟฟ้านี้จะประกอบสร้างอยู่ที่ตู้ควบคุมชั้นล่าง และภายในมีการระบายความร้อนด้วยพัดลมขนาด 4" มีการดูดและเป่าความร้อนออกเพื่อไม่ให้เกิดความเสียหายต่ออุปกรณ์ และการทำงานของชุดควบคุมที่อยู่ด้านบน

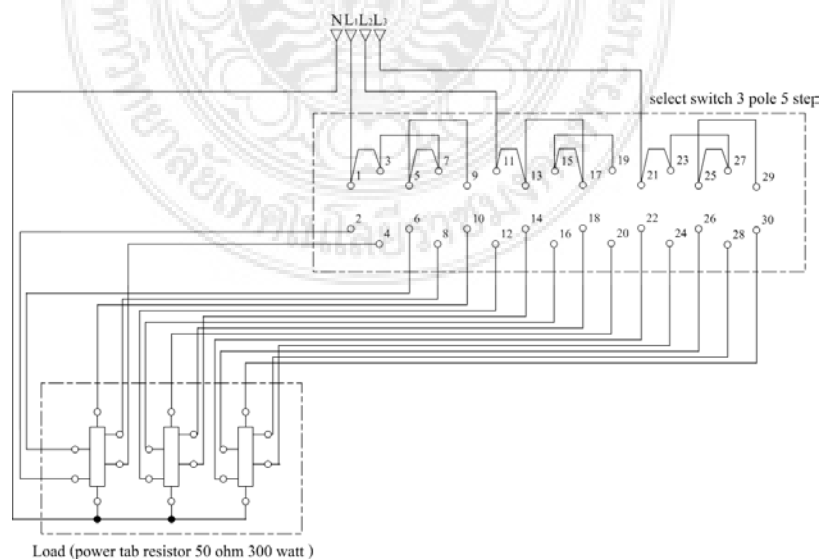

รูปที่ 3.19 ไดอะแกรมวงจรของภาระทางไฟฟ้า

บทที่ 4

การทดลอง

ในบทนี้จะกล่าวถึงการทดลองอุปกรณ์การทำงานของเครื่องกำเนิดไฟฟ้าเพื่อศึกษาคุณลักษณะของเครื่องกำเนิดไฟฟ้ากระแสสลับสามเฟส โดยแบ่งการทดลองออกเป็น 3 กรณีด้วยกัน คือ เครื่องกำเนิดขณะที่ไม่จ่ายโหลด เครื่องกำเนิดขณะจ่ายโหลด การขนานเครื่องกำเนิดเข้าระบบ ซึ่งจะทำให้เข้าใจถึงคุณลักษณะและพฤติกรรมของเครื่องกำเนิดรวมถึงขั้นตอนและวิธีการในการขนานเครื่องกำเนิดเข้าสู่ระบบเมื่อเกิดความผิดพลาดขึ้นจากระบบไฟหลัก ซึ่งเป็นวิธีการที่ใช้ในปัจจุบัน

4.1 การทดลองที่ 1 เครื่องกำเนิดไฟฟ้าขณะที่ไม่จ่ายโหลด

วัตถุประสงค์

1. เพื่อศึกษาคุณลักษณะของเครื่องกำเนิดไฟฟ้าขณะที่ไม่จ่ายโหลด
2. เพื่อเปรียบเทียบความแตกต่างระหว่างระบบไฟหลักกับเครื่องกำเนิดไฟฟ้า

ทฤษฎีที่เกี่ยวข้อง

เครื่องต้นกำลัง (Engine Prime Mover) คือเครื่องยนต์ที่ผลิตพลังงานกล เพื่อนำไปจุดเครื่องกำเนิดไฟฟ้าให้สามารถผลิตไฟฟ้า จ่ายไปยังโหลดที่ต้องการได้



รูปที่ 4.1 เครื่องต้นกำลัง

เครื่องกำเนิดไฟฟ้า (Alternator) คือ คือเครื่องกำเนิดไฟฟ้าแบบกระแสสลับ (A.C. Generator or Generator) ซึ่งมีส่วนประกอบสำคัญคือ Rotor, Stator, Exciter field, AVR (Automatic Voltage Regulator), PMG (Permanent Magnet Generator)

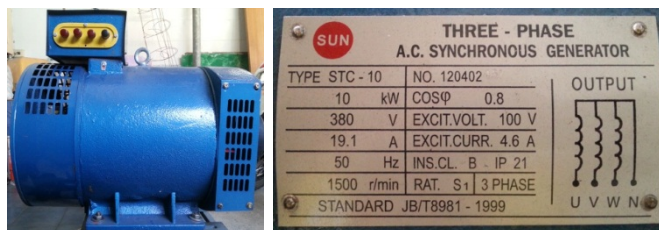

รูปที่ 4.2 เครื่องกำเนิดไฟฟ้า

ชุดควบคุมเครื่องกำเนิดไฟฟ้า แบ่งเป็นระบบควบคุมแบบแมนนวลและอัตโนมัติ แสดงผลได้ทั้งแบบ อนาล็อก และ แบบดิจิทัล

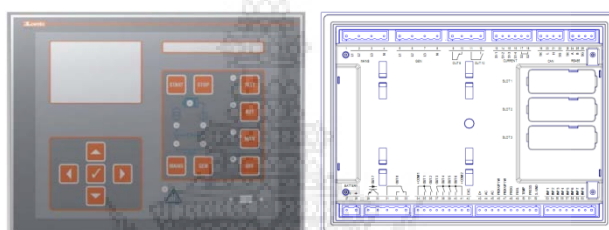

รูปที่ 4.3 เครื่องควบคุมเครื่องกำเนิดไฟฟ้า

การทำงานของเครื่องกำเนิดไฟฟ้ากระแสสลับ ขณะที่ไม่มีโหลด (No - Load)

เครื่องกำเนิดไฟฟ้ากระแสสลับทำงานขณะที่ไม่มีโหลด ที่ปลายสายไม่มีโหลดต่ออยู่ แรงดันไฟฟ้าที่ปลายสายของขดลวดแต่ละเฟส จะมีค่าเท่ากับแรงเคลื่อนไฟฟ้าเหนี่ยวนำ ที่ขดลวดอาเมเจอร์แต่ละเฟส

$$V = E_{\text{PHASE}} = 4.44 \times f \times N \times \phi \times K_p \times K_D$$

เมื่อไม่มีโหลดต่อที่ปลายขดลวดอาเมเจอร์ ทำให้วงจรขดลวดอาเมเจอร์ไม่ครบวงจร ทำให้ไม่มีกระแสเหนี่ยวนำเกิดขึ้น ดังนั้น

$$I = 0$$

อุปกรณ์ในการทดลอง

1. เครื่องกำเนิดไฟฟ้ากระแสสลับสามเฟส
2. แหล่งจ่ายพลังงานไฟฟ้ากระแสสลับสามเฟส
3. ชุดควบคุมเครื่องกำเนิดไฟฟ้า (RGK 700)

ลำดับขั้นตอนการทดลอง

1. ต่อแหล่งจ่ายพลังงานไฟฟ้ากระแสสลับสามเฟส เข้ากับชุดควบคุม
2. ต่อเครื่องกำเนิดไฟฟ้ากระแสสลับสามเฟส เข้ากับชุดควบคุม
3. สตาร์ทเครื่องกำเนิดไฟฟ้ากระแสสลับสามเฟส
4. เปิดสวิตช์ RGK 700
5. เปิดเซอร์กิตเบรกเกอร์ทั้ง MCB และ Gen.CB
6. ตรวจสอบและบันทึกค่าที่อ่านได้จาก RGK 700 ลงในตารางที่ 4.1. ทั้งจากระบบไฟหลัก และจากเครื่องกำเนิดไฟฟ้า
7. คำนวณค่าความแตกต่างของพารามิเตอร์แต่ละค่าระหว่างระบบไฟหลักและเครื่องกำเนิดไฟฟ้าลงในตาราง Accuracy (%)

ตารางที่ 4.1 ตารางการทดลองที่ 1

Parameter	Input	Main	Generator	Accuracy (%)
	Line voltage L1,L2 (V)		342.1	395.1
Line voltage L2,L3 (V)		395.6	393.2	0.46
Line voltage L3,L1 (V)		336.4	390.4	16.19
Frequency (Hz)		50	50	0
Current (A)		-	-	-
Apparent Power (VA)		-	-	-
True Power (W)		-	-	-
Reactive Power (Var)		-	-	-
Power Factor		-	-	-

4.2 การทดลองที่ 2 เครื่องกำเนิดไฟฟ้าขณะจ่ายโหลด

วัตถุประสงค์

1. เพื่อศึกษาคุณลักษณะของเครื่องกำเนิดไฟฟ้าขณะจ่ายโหลด
3. เพื่อศึกษาพฤติกรรมของเครื่องกำเนิดไฟฟ้าเมื่อมีภาระทางไฟฟ้าเพิ่มขึ้น

ทฤษฎีที่เกี่ยวข้อง

เครื่องต้นกำลัง (Engine Prime Mover) คือเครื่องยนต์ที่ผลิตพลังงานกล เพื่อนำไปจุดเครื่องกำเนิดไฟฟ้าให้สามารถผลิตไฟฟ้า จ่ายไปยังโหลดที่ต้องการได้



รูปที่ 4.4 เครื่องต้นกำลัง

เครื่องกำเนิดไฟฟ้า (Alternator) คือ คือเครื่องกำเนิดไฟฟ้าแบบกระแสสลับ (A.C. Generator or Generator) ซึ่งมีส่วนประกอบสำคัญคือ Rotor, Stator, Exciter field, AVR (Automatic Voltage Regulator), PMG (Permanent Magnet Generator)

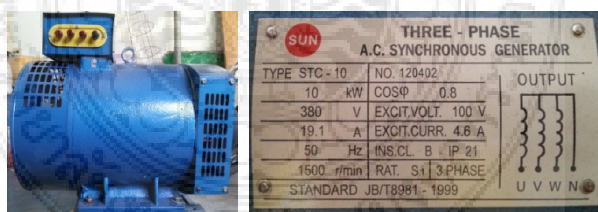

รูปที่ 4.5 เครื่องกำเนิดไฟฟ้า

ชุดควบคุมเครื่องกำเนิดไฟฟ้า แบ่งเป็นระบบควบคุมแบบแมนนวลและอัตโนมัติ แสดงผลได้ทั้งแบบ อนาล็อก และ แบบดิจิตอล

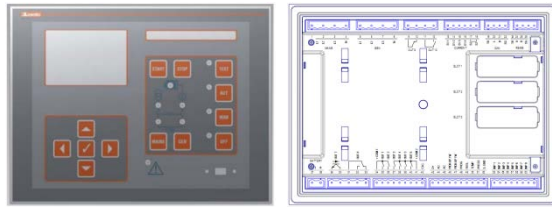

รูปที่ 4.6 เครื่องควบคุมเครื่องกำเนิดไฟฟ้า

การทำงานของเครื่องกำเนิดไฟฟ้ากระแสสลับ ขณะที่มีโหลด (On – Load)

เมื่อมีโหลดมาต่อเข้าที่ปลายสายเครื่องกำเนิดไฟฟ้า ขณะที่เครื่องกำเนิดไฟฟ้าสร้างแรงเคลื่อนไฟฟ้าเหนี่ยวนำ ทำให้แรงดันไฟฟ้าที่ปลายสายลดลง ทำให้มีกระแสไหลครบวงจรอามเมอร์ สาเหตุที่ทำให้แรงดันไฟฟ้าปลายสายลดลง มีดังนี้

1. Armature Resistance ($I_a R_a$)
2. Leakage flux Reactance ($I_a X_L$)
3. Armature Reaction ($I_a X_a$)

1. Armature Resistance ($I_a R_a$)

ตามปกติการพันขดลวด ที่ล่งสล็อตของสเตเตอร์ มีความยาวทำให้เกิดความต้านทานขึ้น ดังนั้นเมื่อเกิดกระแสไหลในอามเมอร์ จะทำให้เกิดแรงดันตกคร่อม (IARA) ตามปกติ ความต้านทานประสิทธิผล (Effective Resistance) มีค่าสูงกว่าความต้านทานกระแสตรง ประมาณ 115-175% ในทางคำนวณใช้ค่าประมาณ 150% ทางการค้าในเครื่องกำเนิดไฟฟ้าขนาดใหญ่ ค่า Armature Resistance ไม่คิดเพราะน้อยมากเมื่อเทียบกับค่า Reactance ($X_S = X_A + X_L$)

$$R_{ac} = 1.5 \times R_{dc}$$

2. Leakage Flux Reactance ($I_a X_L$)

เมื่อกระแสไหลเข้าสู่ขดลวด จำนวนรอบการพันขดลวดทำให้เกิด Leakage Flux ซึ่งฟลักซ์นี้จะไปเหนี่ยวนำจำนวนรอบการพันของอีกขดลวดหนึ่ง ทำให้เกิดค่า Inductance ของขดลวดขึ้น

$$X_L = 2\pi fL$$

เมื่อกระแสไหลผ่านทำให้เกิด Reactance Drop

$$IX_L = I \times 2\pi \times f \times L$$

3. Armature Reaction ($I_a X_a$)

เครื่องกำเนิดไฟฟ้ากระแสสลับ Armature Reaction เกิดขึ้นจากกระแสไฟฟ้าที่ไหลเข้าไปยังขดลวดอาเมเจอร์ ซึ่งจะสร้าง สนามแม่เหล็กเหนี่ยวนำซึ่งมีทิศทางเสริมหรือต้านกับสนามแม่เหล็กเหนี่ยวนำที่สร้างขึ้นจากขั้วแม่เหล็ก จะมีอยู่ 3 ลักษณะคือ

1. โหลดมีค่าพาวเวอร์แฟคเตอร์เป็นหนึ่ง กระแสและแรงเคลื่อนไฟฟ้าเหนี่ยวนำมีเฟสเดียวกัน (Inphase) เมื่อขดลวดสนามแม่เหล็กหมุน จะเกิดแรงเคลื่อนไฟฟ้าเหนี่ยวนำสูงสุด เนื่องจากขดลวดอาเมเจอร์เคลื่อนที่ตัดกับเส้นแรงแม่เหล็กตรงกึ่งกลางขั้วพอดี แต่ไม่มีกระแสไหลผ่าน ขดลวดอาเมเจอร์ ความหนาแน่นของเส้นแรงแม่เหล็กจะสมมาตร เมื่อ ต่อ โหลดเข้าไป จะมีกระแสไหลผ่านขดลวดอาเมเจอร์ทำให้เส้นแรงแม่เหล็กขั้ว N และ S จะบิดเบนไป ความหนาแน่น เส้นแรงแม่เหล็กด้านซ้ายมือจะน้อยกว่าด้านขวามือ
2. โหลดมีค่าพาวเวอร์แฟคเตอร์ล่าหลัง กระแสล่าหลังแรงดันไฟฟ้าประมาณ 90 องศา เส้นแรงแม่เหล็กที่เกิดขึ้นจากอาเมเจอร์มีทิศทางตรงข้ามกับเส้นแรงแม่เหล็กที่ขั้วแม่เหล็ก ทำให้เส้นแรงแม่เหล็กที่ขั้วแม่เหล็กลดลง ทำให้แรงเคลื่อนไฟฟ้าเหนี่ยวนำมีค่าลดลงด้วย ในกรณีจะต้องเพิ่มการกระตุ้นที่ขดลวดฟิลด์คอยล์ เพื่อให้แรงเคลื่อนไฟฟ้าเหนี่ยวนำสูงขึ้น
3. โหลดมีค่าพาวเวอร์แฟคเตอร์นำหน้า กระแสจะนำหน้าแรงดันไฟฟ้า ประมาณ 90 องศา เส้นแรงแม่เหล็กที่เกิดขึ้นจากขดลวดอาเมเจอร์ จะมีทิศทางเดียวกับเส้นแรงแม่เหล็กจากขั้วแม่เหล็ก ทำให้เส้นแรงแม่เหล็กเสริมกับ แรงเคลื่อนไฟฟ้าเหนี่ยวนำจึงสูงขึ้น เมื่อต้องการให้แรงเคลื่อนไฟฟ้าคงที่ต้องลดกระแสที่ขดลวดฟิลด์ให้ลดลง

โดยปกติขนาดหรือพิกัดของเครื่องกำเนิดไฟฟ้ากระแสสลับจะบอกเป็นหน่วย กิโลโวลต์แอมแปร์ หรือ เมกกะโวลต์แอมแปร์ เพราะเครื่องกำเนิดไฟฟ้าทำงานที่โหลดและพาวเวอร์แฟคเตอร์แตกต่างกัน ในบางครั้งจะบอกเป็น กิโลวัตต์ หรือ เมกกะวัตต์ เป็นค่ากำลังไฟฟ้าที่เครื่องกำเนิดไฟฟ้าป้อนให้โหลด และบอกค่าพาวเวอร์แฟคเตอร์ของโหลดด้วย ถ้าไม่บอก ค่าพาวเวอร์แฟคเตอร์ให้ตั้งสมมุติฐานว่า โหลดมีค่าพาวเวอร์แฟคเตอร์นำเป็น 1 หรือ 100% และหน่วยเป็น กิโลโวลต์แอมแปร์ หรือ เมกกะโวลต์แอมแปร์

อุปกรณ์ในการทดลอง

1. เครื่องกำเนิดไฟฟ้ากระแสสลับสามเฟส
2. แหล่งจ่ายพลังงานไฟฟ้ากระแสสลับสามเฟส

3. ชุดควบคุมเครื่องกำเนิดไฟฟ้า (RGK 700)

ลำดับขั้นตอนการทดลอง

1. ต่อแหล่งจ่ายพลังงานไฟฟ้ากระแสสลับสามเฟส เข้ากับชุดควบคุม
2. ต่อเครื่องกำเนิดไฟฟ้ากระแสสลับสามเฟส เข้ากับชุดควบคุม
3. สตาร์ทเครื่องกำเนิดไฟฟ้ากระแสสลับสามเฟส
4. เปิดสวิตช์ RGK 700
5. เปิดเซอร์กิตเบรกเกอร์ทั้ง MCB และ Gen.CB
6. เลือกโหมด Manual เลือกให้ Gen.Mag. ทำงานเพื่อให้เครื่องกำเนิดไฟฟ้าจ่ายโหลด
7. ทำการปรับเพิ่มโหลดตั้งแต่ Step 1-5 แล้วทำการบันทึกค่าพารามิเตอร์ของแต่ละ Step ลงในตารางบันทึกผลการทดลอง

ตารางที่ 4.2 ตารางผลการทดลองที่ 2 (R = 1000 Ω)

Step Parameter	1 (20%)	2 (40%)	3 (60%)	4 (80%)	5 (100%)
Line voltage L1,L2 (V)	378.7	385.4	389.4	392.6	392.6
Line voltage L2,L3 (V)	378.3	384.4	385.8	389.7	392.4
Line voltage L3,L1 (V)	375.6	383.9	387.4	388.0	390.4
Frequency (Hz)	50	50	50	50	50
Current (A)	1.3	0.6	0.425	0.285	0.25
Apparent Power (VA)	283.36	133.22	95.089	64.19	56.55
True Power (W)	282.1	132.5	90.1	62.5	52.2
Reactive Power (Var)	25.317	13.305	66.370	14.542	21.76
Power Factor	0.996	0.995	0.948	0.974	0.923

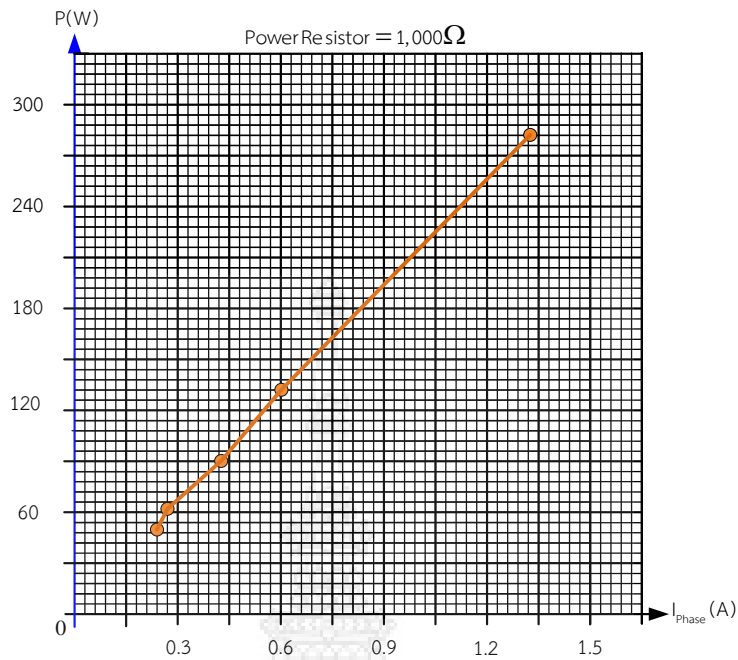

รูปที่ 4.7 กราฟผลการทดลองที่ 2 (Power Resistor = 1000โอห์ม)

คำถามท้ายการทดลองที่ 2

1. คำนวณหาค่ากำลังไฟฟ้าแล้วนำมาเปรียบเทียบกับค่าที่ได้จากการทดลอง (Load 40 %)

ตารางที่ 4.3 เปรียบเทียบค่าจากการคำนวณกับการทดลอง

ค่ากำลังไฟฟ้า	ค่าที่ได้จากการทดลอง	ค่าที่ได้จากการคำนวณ	Accuracy (%)
Apparent Power (VA)	95.089	80	15.868
True Power (W)	90.1	64	28.968
Reactive Power (Var)	66.370	48	27.678

2. นำค่ากำลังไฟฟ้าจากข้อที่ 1 เขียนภาพสามเหลี่ยมกำลังไฟฟ้าแสดงค่ากำลังไฟฟ้าที่ได้จากการทดลองและค่ากำลังไฟฟ้าที่ได้จากการคำนวณ (Load ที่ 40 %)

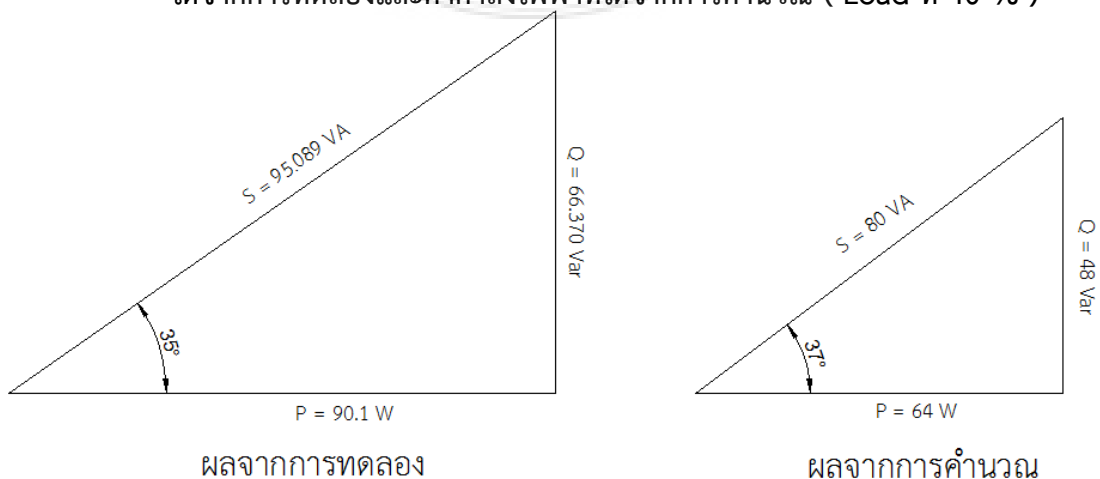

4.3 การทดลองที่ 3 การขนานเครื่องกำเนิดไฟฟ้าเข้าระบบ (ชิงค์ขาไป, ชิงค์ขากลับ)

วัตถุประสงค์

1. เพื่อศึกษาคุณลักษณะของเครื่องกำเนิดไฟฟ้าก่อนขนานและหลังจากขนานเข้าระบบ
2. เพื่อศึกษาพฤติกรรมของเครื่องกำเนิดไฟฟ้าก่อนขนานและหลังจากขนานเข้าระบบ
3. เพื่อมีความรู้และความเข้าใจในขั้นตอนและวิธีการ ชิงค์ขาไป และ ชิงค์ขากลับ

ทฤษฎีที่เกี่ยวข้อง

เครื่องกำเนิดไฟฟ้าสามารถนำมาเดินขนานกับเครื่องกำเนิดไฟฟ้าหรือกับไฟหลวงได้ แต่ก่อนที่แหล่งกำเนิดไฟฟ้าสองแหล่งจะขนานกันได้นั้น ชุดควบคุมการขนานจะต้องเช็ค โวลต์ ความถี่ และ มุมต่างเฟส ให้ตรงกันเสียก่อนที่จะสับให้ไฟเข้ามาขนานกันเพื่อจ่ายโหลดต่อไป ซึ่งลักษณะของการชิงค์นั้น โดยทั่วไปมักจะเรียกว่า ชิงค์ขาไป กับ ชิงค์ขากลับ



รูปที่ 4.8 อุปกรณ์ควบคุมและเครื่องกำเนิดไฟฟ้า

ชิงค์ขาไป หมายถึง สถานการณ์ที่ทราบแล้วว่าไฟหลวงจะดับ ดังนั้นจึงสั่งสตาร์ทเครื่องกำเนิดไฟฟ้าแล้วนำไฟจากเครื่องกำเนิดไฟฟ้าขนานเข้ากับไฟหลวงก่อนที่ไฟจะดับ ซึ่งเมื่อไฟหลวงดับไปแล้วแต่ก็ยังมีไฟจากเจนคอยจ่ายให้กับโหลดอยู่นั่นเอง (สังเกตว่าลักษณะการทำงานเช่นนี้จะไม่มีความเสียหายไปเลย) หรืออาจจะเป็นลักษณะของการขนานเครื่องกำเนิดไฟฟ้าหลาย ๆ เครื่องเข้าด้วยกันก่อนแล้วขนานกับไฟหลวงอีกทีก็ได้ ตัวอย่างการใช้งานเช่นนี้พบได้มากในยุคที่ราคาของน้ำมันดีเซลยังราคาถูก ก็จะเดินเครื่องกำเนิดไฟฟ้าจ่ายไฟให้กับโหลดเพื่อตัดพีค ของการไฟฟ้า แต่ในปัจจุบันราคาน้ำมันดีเซลสูงเกินกว่าที่จะเดินเครื่องเพื่อตัดพีคแล้ว

ชิงค์ขากลับ หมายถึง สถานการณ์ที่ไฟดับไปแล้ว และใช้เครื่องกำเนิดไฟฟ้าจ่ายไฟให้กับโหลดอยู่ และหลังจากที่ไฟหลวงกลับมาจะนำไฟหลวงมาขนานเข้ากับไฟจากเครื่องกำเนิดไฟฟ้าก่อนแล้วจึงค่อยปลดไฟจากเครื่องกำเนิดไฟฟ้าออก (สังเกตว่าลักษณะเช่นนี้ก็จะไม่มีไฟขาดหายไปเช่นกัน)

อุปกรณ์ในการทดลอง

1. เครื่องกำเนิดไฟฟ้ากระแสสลับสามเฟส
2. แหล่งจ่ายพลังงานไฟฟ้ากระแสสลับสามเฟส
3. ชุดควบคุมเครื่องกำเนิดไฟฟ้า (RGK 700)

ลำดับขั้นตอนการทดลอง

1. ต่อแหล่งจ่ายพลังงานไฟฟ้ากระแสสลับสามเฟส เข้ากับชุดควบคุม
2. ต่อเครื่องกำเนิดไฟฟ้ากระแสสลับสามเฟส เข้ากับชุดควบคุม
3. สตาร์ทเครื่องกำเนิดไฟฟ้ากระแสสลับสามเฟส
4. เปิดสวิตช์ RGK 700
5. เปิดเซอร์กิตเบรกเกอร์ทั้ง MCB และ Gen.CB
6. เลือกโหมด Auto ให้ระบบไฟหลักทำการจ่ายโหลดตามปกติก่อน
7. ทำการปรับโหลดไปที่ Step 3 แล้วทำการบันทึกค่าพารามิเตอร์ลงในตารางบันทึกผลการทดลอง
8. หลังจากนั้นให้ทำการปิด MCB ลงเพื่อให้ RGK 700 ย้ายโหลดจากไฟหลักมารับไฟที่เครื่องกำเนิดแทนแล้วทำการบันทึกค่าพารามิเตอร์ลงในตารางบันทึกผลการทดลอง
9. หลังจากนั้นให้ทำการเปิด MCB เพื่อให้ RGK 700 ย้ายโหลดจากเครื่องกำเนิดมารับไฟจากระบบไฟหลัก แล้วทำการบันทึกค่าพารามิเตอร์ลงในตารางบันทึกผลการทดลอง

ตารางที่ 4.4 ก่อนทำการ ชิงค์เข้าไป (Load 40 %) (R = 1000โอห์ม)

Parameter \ Input	Main	Generator	Accuracy (%)
Line voltage L1,L2 (V)	342.1	359.4	5.057
Line voltage L2,L3 (V)	395.6	385.8	2.478
Line voltage L3,L1 (V)	336.4	387.4	15.161
Frequency (Hz)	50	50	0
Current (A)	0.6	-	-
Apparent Power (VA)	137.04	-	-
True Power (W)	132.5	-	-
Reactive Power (Var)	34.982	-	-
Power Factor	0.967	-	-

ตารางที่ 4.5 หลังทำการ ชิงค์ขาไป (Load 40 %) (R = 1000โอห์ม)

Input Parameter	Main	Generator	Accuracy (%)
Line voltage L1,L2 (V)	-	385.4	-
Line voltage L2,L3 (V)	-	384.4	-
Line voltage L3,L1 (V)	-	383.9	-
Frequency (Hz)	-	50	-
Current (A)	-	0.6	-
Apparent Power (VA)	-	133.22	-
True Power (W)	-	132.5	-
Reactive Power (Var)	-	13.305	-
Power Factor	-	0.6	-

ตารางที่ 4.6 หลังทำการ ชิงค์ขากลับ (Load 40 %) (R = 1000โอห์ม)

Input Parameter	Main	Generator	Accuracy (%)
Line voltage L1,L2 (V)	342.1	359.4	5.057
Line voltage L2,L3 (V)	395.6	385.8	2.478
Line voltage L3,L1 (V)	336.4	387.4	15.161
Frequency (Hz)	50	50	0
Current (A)	0.6	-	-
Apparent Power (VA)	137.04	-	-
True Power (W)	132.5	-	-
Reactive Power (Var)	34.982	-	-
Power Factor	0.967	-	-

ตารางที่ 4.7 เปรียบเทียบค่าพารามิเตอร์ของเครื่องกำเนิดไฟฟ้าที่สภาวะต่างๆ
(Load 40 %) (R = 1000 โอห์ม)

State of Gen. Parameter	ก่อนทำการซิงค์	ซิงค์ขาไป	ซิงค์ขากลับ
Line voltage L1,L2 (V)	359.4	385.4	359.4
Line voltage L2,L3 (V)	385.8	384.4	385.8
Line voltage L3,L1 (V)	387.4	383.9	387.4
Frequency (Hz)	50	50	50
Current (A)	-	0.6	-
Apparent Power (VA)	-	133.22	-
True Power (W)	-	132.5	-
Reactive Power (Var)	-	13.305	-
Power Factor	-	0.6	-



บทที่ 5

สรุปผลการทดลอง ปัญหาและข้อเสนอแนะ

โครงการนี้จัดทำขึ้นโดยมีวัตถุประสงค์คือ เพื่อสร้างเครื่องกำเนิดไฟฟ้ากระแสสลับสามเฟส 380 โวลต์แอมแปร์ 10 กิโลวัตต์ 50 เฮิร์ต และเครื่องยนต์ต้นกำลังขนาด 9 แรงม้า 4 จังหวะ สูบเดี่ยว รวมทั้งชุดควบคุม เครื่องกำเนิดไฟฟ้าที่สามารถแสดงค่าต่าง ๆ ของเครื่องกำเนิดไฟฟ้า รวมทั้งยังมีการจำลองภาระทางไฟฟ้า เพื่อจำลองการทำงานของเครื่องกำเนิดในขณะที่ยังทำการจ่ายโหลดขณะที่ทำการจ่ายโหลด หรือ ขณะที่ขนานเครื่องกำเนิดไฟฟ้าเข้าสู่ระบบเมื่อระบบหลักเกิดความผิดปกติ และนำระบบหลักกลับมาจ่ายโหลดอีกครั้งเมื่อระบบหลักกลับสู่สภาวะปกติแล้ว โดยผลสรุปของการทดลองทั้ง 3 มีดังนี้

5.1 ผลการทดลองที่ 1 เครื่องกำเนิดไฟฟ้าขณะที่ไม่จ่ายโหลด

ตารางที่ 5.1 ผลการทดลองที่ 1 เครื่องกำเนิดไฟฟ้าขณะที่ไม่จ่ายโหลด

Input Parameter	Main	Generator	Accuracy (%)
Line voltage L1,L2 (V)	342.1	395.1	15.52
Line voltage L2,L3 (V)	395.6	393.2	0.46
Line voltage L3,L1 (V)	336.4	390.4	16.19
Frequency (Hz)	50	50	0
Current (A)	-	-	-
Apparent Power (VA)	-	-	-
True Power (W)	-	-	-
Reactive Power (Var)	-	-	-
Power Factor	-	-	-

สรุปผลการทดลองที่ 1

จากการทดลองพบว่าเมื่อไม่มีภาระทางไฟฟ้าก็จะมีกระแสไฟฟ้าเกิดขึ้นในระบบและเมื่อไม่มีกระแสไฟฟ้าก็ไม่มีค่ากำลังไฟฟ้าเกิดขึ้นด้วยในระบบ ซึ่งเป็นไปตามสมการ

$$P = E \times I \quad \text{เมื่อ } I = 0 \text{ เมื่อแทนค่าไปในสมการจะทำให้ } P \text{ ได้ } = 0$$

$$P = E \times I \times \sin(\theta) \quad \text{เมื่อ } I = 0 \quad \text{เมื่อแทนค่าไปในสมการจะทำให้ } P \text{ ได้ } = 0$$

$$P = E \times I \times \cos(\theta) \quad \text{เมื่อ } I = 0 \quad \text{เมื่อแทนค่าไปในสมการจะทำให้ } P \text{ ได้ } = 0$$

เมื่อกำลังไฟฟ้าของระบบมีค่าเป็น 0 ทำให้พิจารณาได้เพียงแรงดันของระบบไฟฟ้าหลัก กับแรงดันของเครื่องกำเนิดไฟฟ้า ซึ่งจะมีค่าแตกต่างกัน โดยที่แรงดันของระบบไฟฟ้าหลักมีค่ามากกว่า เนื่องมาจากการปรับแก้ของหม้อแปลงไฟฟ้า เพราะไฟที่มาจากระบบหลักเป็นการจ่ายโหลด ส่วนรวมจึงต้องส่งแรงดันมาให้มากกว่าหรือน้อยกว่า 380 โวลต์แต่สำหรับเครื่องกำเนิด เป็นการผลิตและจำหน่ายเพื่อสำหรับชุดทดลองเพียงอย่างเดียว จึงทำให้สามารถผลิตแรงดันไฟฟ้าได้ใกล้เคียงกับ 380 โวลต์หรือมากกว่าเพราะไม่มีโหลดตัวอื่นมาเกี่ยวข้องและยังมีเสถียรภาพและความเที่ยงตรงมากกว่าระบบไฟฟ้าหลัก

5.2 ผลการทดลองที่ 2 เครื่องกำเนิดไฟฟ้าขณะจ่ายโหลด

ตารางที่ 5.2 ผลการทดลองที่ 2 (R = 1000โอห์ม)

Step Parameter	1 (20%)	2 (40%)	3 (60%)	4 (80%)	5 (100%)
Line voltage L1,L2 (V)	378.7	385.4	389.4	392.6	392.6
Line voltage L2,L3 (V)	378.3	384.4	385.8	389.7	392.4
Line voltage L3,L1 (V)	375.6	383.9	387.4	388.0	390.4
Frequency (Hz)	50	50	50	50	50
Current (A)	1.3	0.6	0.425	0.285	0.25
Apparent Power (VA)	283.36	133.22	95.089	64.19	56.55
True Power (W)	282.1	132.5	90.1	62.5	52.2
Reactive Power (Var)	25.317	13.305	66.370	14.542	21.76
Power Factor	0.996	0.995	0.948	0.974	0.923

สรุปผลการทดลองที่ 2

จากการทดลองพบว่าเมื่อมีภาระทางไฟฟ้าเกิดขึ้น ทำให้มีกระแสไฟฟ้าไหลในระบบจึงเกิดกำลังไฟฟ้าในส่วนต่างๆแบ่งเป็น 3 ส่วน ได้ดังนี้

- Apparent power $S = V \times I$ (VA)
- Real power $P = V \times I \times \cos(\theta)$ (W)
- Reactive power; $Q = V \times I \times \sin(\theta)$ (VAR)

และทำให้เกิดค่าพาวเวอร์ขึ้น ซึ่งค่าพาวเวอร์นี้เป็นตัวประกอบของกำลังไฟฟ้าที่กำหนดให้ต้องใช้กำลังไฟฟ้าปรากฏมากหรือน้อยในการที่จะทำให้อุปกรณ์ทำงานจริง ซึ่งเป็นไปตามสามเหลี่ยมของกำลังไฟฟ้า ในกรณีนี้ภาระทางไฟฟ้า ใช้ Load - R เพียงอย่างเดียวทำให้มีค่าพาวเวอร์ที่ใกล้เคียงกับ 1 ถ้าหากมีการประยุกต์ใช้ Load - L และ Load - C เข้ามาในระบบอาจทำให้การทดลองมีความชัดเจนมากยิ่งขึ้น

เมื่อทำการปรับระดับของภาระทางไฟฟ้าให้เพิ่มขึ้น พบว่าแรงดันของเครื่องกำเนิดไฟฟ้ามีการแกว่งเล็กน้อย แต่น้อยมากจนไม่ส่งผลกระทบต่อระบบและค่อนข้างจะมีความเสถียรทั้งแรงดันและความถี่เนื่องจากการผลิตและจ่ายให้กับชุดจำลองเพียงอย่างเดียว ซึ่งในภาระทางไฟฟ้า จริงของระบบอาจจะมีภาระทางไฟฟ้า จำพวก L หรืออุปกรณ์อิเล็กทรอนิกส์ ที่ทำให้เกิด ฮาร์โมนิกส์ ซึ่งส่งผลต่อแรงดันและความถี่ของระบบไฟฟ้า

5.3 ผลการทดลองที่ 3 การขนานเครื่องกำเนิดไฟฟ้าเข้าระบบในสภาวะต่างๆ

ตารางที่ 5.3 ก่อนทำการ ชิงค์เข้าไป (Load 40 %) (R=1000โอห์ม)

Input Parameter	Main	Generator	Accuracy (%)
Line voltage L1,L2 (V)	342.1	359.4	5.057
Line voltage L2,L3 (V)	395.6	385.8	2.478
Line voltage L3,L1 (V)	336.4	387.4	15.161
Frequency (Hz)	50	50	0
Current (A)	0.6	-	-
Apparent Power (VA)	137.04	-	-
True Power (W)	132.5	-	-
Reactive Power (Var)	34.982	-	-
Power Factor	0.967	-	-

ตารางที่ 5.4 หลังจากทำการ ชิงค์เข้าไป (Load 40 %) (R = 1000โอห์ม)

Input Parameter	Main	Generator	Accuracy (%)
Line voltage L1,L2 (V)	-	385.4	-
Line voltage L2,L3 (V)	-	384.4	-
Line voltage L3,L1 (V)	-	383.9	-
Frequency (Hz)	-	50	-
Current (A)	-	0.6	-
Apparent Power (VA)	-	133.22	-
True Power (W)	-	132.5	-
Reactive Power (Var)	-	13.305	-
Power Factor	-	0.6	-

ตารางที่ 5.5 หลังจากทำการ ชิงค์ขากลับ (Load 40 %) (R = 1000โอห์ม)

Input Parameter	Main	Generator	Accuracy (%)
Line voltage L1,L2 (V)	342.1	359.4	5.057
Line voltage L2,L3 (V)	395.6	385.8	2.478
Line voltage L3,L1 (V)	336.4	387.4	15.161
Frequency (Hz)	50	50	0
Current (A)	0.6	-	-
Apparent Power (VA)	137.04	-	-
True Power (W)	132.5	-	-
Reactive Power (Var)	34.982	-	-
Power Factor	0.967	-	-

ตารางที่ 5.6 เปรียบเทียบค่าพารามิเตอร์ของเครื่องกำเนิดไฟฟ้าที่สภาวะต่างๆ
(Load 40 %) (R = 1000โอห์ม)

State of Gen. Parameter	ก่อนทำการชิงค์	ชิงค์ขาไป	ชิงค์ขากลับ
Line voltage L1,L2 (V)	359.4	385.4	359.4
Line voltage L2,L3 (V)	385.8	384.4	385.8
Line voltage L3,L1 (V)	387.4	383.9	387.4
Frequency (Hz)	50	50	50
Current (A)	-	0.6	-
Apparent Power (VA)	-	133.22	-
True Power (W)	-	132.5	-
Reactive Power (Var)	-	13.305	-
Power Factor	-	0.6	-

สรุปผลการทดลองที่ 3

จากการทดลองทำให้ทราบถึงขั้นตอนการชิงค์ขาไปและขากลับ

จากตารางที่ 4.4 พบว่าขณะนี้ระบบไฟฟ้าหลักทำการจ่ายภาระทางไฟฟ้าอยู่ แล้วทางด้านเครื่องกำเนิดไฟฟ้ามีการเดินเครื่องรอไว้สาเหตุต้องเดินเครื่องรอไว้ เนื่องจากเป็นเพียงแค่การทดลองที่จำลองขึ้นมาในปกติที่ใช้อยู่ทั่วไปจะเป็นการสั่งให้เครื่องกำเนิดไฟฟ้าจ่ายโดยอัตโนมัติ แต่มีการใช้ค่าใช้จ่ายสูงมาก ด้วยเหตุผลขั้นต้นจึงต้องมีการเดินเครื่องรอไว้เพื่อที่จะชิงค์เครื่องกำเนิดไฟฟ้าเข้าระบบ

จากตารางที่ 4.5 พบว่า ขณะนี้ระบบไฟฟ้าหลักได้หายไปหรือเกิดความผิดพลาดขึ้นทำให้ภาระทางไฟฟ้าถูกถ่ายไปที่เครื่องกำเนิดไฟฟ้า โดยการนำเครื่องกำเนิดไฟฟ้าเข้าสู่ระบบนั้นจะหน่วงเวลาไว้ที่ 15 วินาที เพื่อเป็นการป้องกันการเกิด บราวเอาท์ ของระบบ ซึ่งเป็นการที่ระบบหายไปแล้วสามารถกลับคืนมาได้เองในระยะเวลาสั้น ๆ หากนำเครื่องกำเนิดไฟฟ้าเข้าสู่ระบบแล้วก็จะเป็นการใช้เครื่องกำเนิดไฟฟ้าโดยไม่จำเป็น

จากตารางที่ 4.6 พบว่าขณะนี้ระบบไฟฟ้าหลักได้กลับมาสู่ภาวะปกติแล้ว จากนั้นทำการหน่วงเวลา 15 วินาที เพื่อเป็นการยืนยันว่าระบบกลับมาอย่างถาวร เครื่องกำเนิดไฟฟ้าจะถูกปลดออกจากระบบและนำระบบไฟฟ้าหลักเข้ามาจ่ายภาระทางไฟฟ้าแทน

จากตารางที่ 4.7 เป็นการเปรียบเทียบค่าพารามิเตอร์ของเครื่องกำเนิดไฟฟ้า ก่อนทำการซิงค์ - ขาไป และ ซิงค์ - ขากลับ

5.4 ปัญหาที่พบระหว่างการทดลอง

1. เนื่องจากเครื่องกำเนิดไฟฟ้าเป็นเครื่องยนต์ที่ใช้การสตาร์ทด้วยมือจึงไม่สามารถสั่งให้ทำงานโดยอัตโนมัติได้ทำให้ในกรณีขนานเครื่องกำเนิดไฟฟ้าจึงต้องสตาร์ทเครื่องกำเนิดไฟฟ้ารอไว้ก่อนถ้าเป็นแบบที่ใช้ในอาคารทั่วไปจะเป็นแบบอัตโนมัติ

2. ในขณะที่เครื่องกำเนิดไฟฟ้าทำงานมีเสียงและแรงสั่นสะเทือนที่เป็นผลจากการทำงานของเครื่องยนต์ทำให้เกิดเสียงและแรงสั่นสะเทือนค่อนข้างมาก

5.5 ข้อเสนอแนะ

1. ทำการติดตั้งระบบสตาร์ทอัตโนมัติให้กับเครื่องยนต์โดยระบบสตาร์ทอัตโนมัตินี้สามารถสั่งการผ่าน RGK 700 ได้ เครื่องกำเนิดก็จะสามารถสตาร์ทโดยอัตโนมัติได้ตามฟังก์ชันที่มีอยู่ของ RGK 700

2. ทำการติดตั้งแผ่นยางรองตามจุดต่อต่างๆเพื่อลดเสียงและการสั่นสะเทือนของชุดเครื่องกำเนิดไฟฟ้า

บรรณานุกรม

- ซัด อินทะลี. 2552. **วงจรไฟฟ้ากระแสสลับ**. กรุงเทพฯ : สำนักงานคณะกรรมการอาชีวศึกษา
 ไซยชาญ หินเกิด. 2549. **เครื่องกลไฟฟ้า 2**. พิมพ์ครั้งที่ 5. กรุงเทพฯ : สมาคมส่งเสริมเทคโนโลยี
 ไทย-ญี่ปุ่น
- ธวัชชัย อັตถวิบูลย์ และคณะ. 2546. **การควบคุมเครื่องกลไฟฟ้า**. พิมพ์ครั้งที่ 2. กรุงเทพฯ : ศูนย์
 อาชีวะ
- ธวัชชัย อັตถวิบูลย์. 2547. **เครื่องกำเนิดไฟฟ้ากระแสสลับ**. พิมพ์ครั้งที่ 3. กรุงเทพฯ : ศูนย์ส่งเสริม
 อาชีวะ
- นภัทร วัฒนเทพนคร. 2545. **เครื่องวัดไฟฟ้าภาคปฏิบัติ**. พิมพ์ครั้งที่ 2. กรุงเทพฯ : ศูนย์ส่งเสริม
 อาชีวะ
- ปัญญา ยอดโอวาท. 2544. **เครื่องกลไฟฟ้ากระแสสลับและการควบคุม**. กรุงเทพฯ : จุฬาลงกรณ์
 มหาวิทยาลัย
- พันธ์ศักดิ์ พุฒิมานิตพงศ์ และคณะ. 2546. **เครื่องวัดไฟฟ้า**. พิมพ์ครั้งที่ 3. กรุงเทพฯ : ศูนย์ส่งเสริม
 อาชีวะ

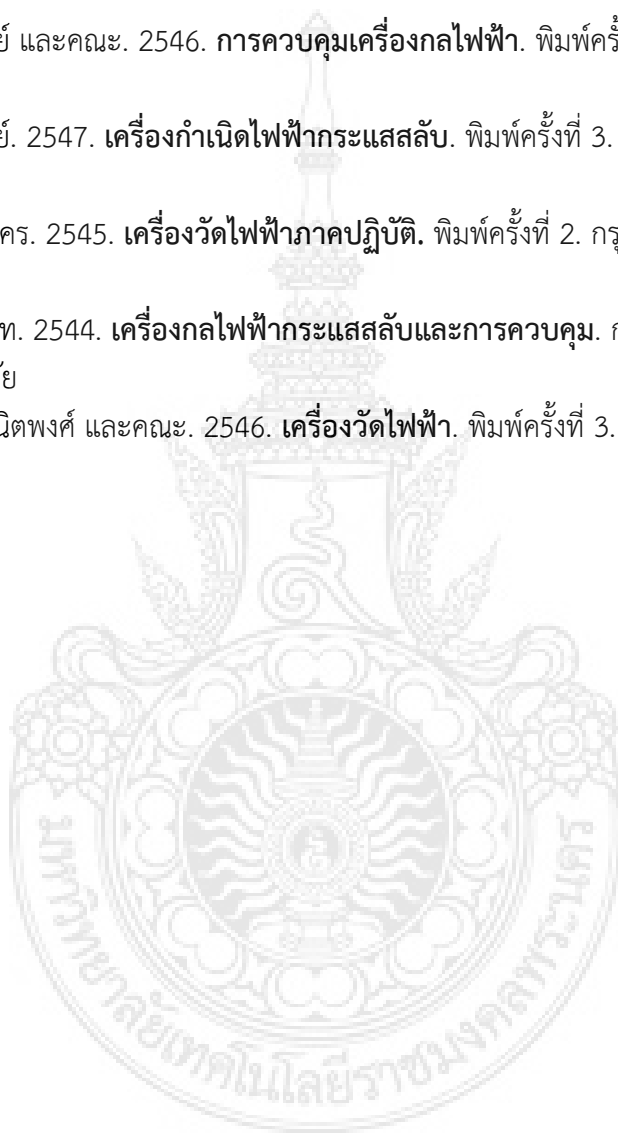

ภาคผนวก ก
คู่มือการใช้งานของ
Controller Generator RGK 800





LOVATO ELECTRIC S.P.A.

24020 GORLE (BERGAMO) ITALIA
VIA DON E. MAZZA, 12
TEL. 035 4282111
TELEFAX (Nazionale): 035 4282200
TELEFAX (Internazionale): +39 035 4282400
Web www.LovatoElectric.com
E-mail info@LovatoElectric.com

RGK800 RGK800SA

Unità di controllo
per gruppi elettrogeni

MANUALE OPERATIVO



RGK800 RGK800SA

Generating set
control unit

INSTRUCTIONS MANUAL



ATTENZIONE!!

- Leggere attentamente il manuale prima dell'utilizzo e l'installazione.
- Questi apparecchi devono essere installati da personale qualificato, nel rispetto delle vigenti normative impiantistiche, allo scopo di evitare danni a persone o cose.

- Prima di qualsiasi intervento sullo strumento, togliere tensione dagli ingressi di misura e di alimentazione e cortocircuitare i trasformatori di corrente.
- Il costruttore non si assume responsabilità in merito alla sicurezza elettrica in caso di utilizzo improprio del dispositivo.
- I prodotti descritti in questo documento sono suscettibili in qualsiasi momento di evoluzioni o di modifiche. Le descrizioni ed i dati a catalogo non possono pertanto avere alcun valore contrattuale.
- Un interruttore o disgiuntore va compreso nell'impianto elettrico dell'edificio. Esso deve trovarsi in stretta vicinanza dell'apparecchio ed essere facilmente raggiungibile da parte dell'operatore. Deve essere marchiato come il dispositivo di interruzione dell'apparecchio: IEC/EN 61010-1 § 6.12.2.1.
- Pulire lo strumento con panno morbido, non usare prodotti abrasivi, detergenti liquidi o solventi.



WARNING!

- Carefully read the manual before the installation or use.
- This equipment is to be installed by qualified personnel, complying to current standards, to avoid damages or safety hazards.

- Before any maintenance operation on the device, remove all the voltages from measuring and supply inputs and short-circuit the CT input terminals.
- Products illustrated herein are subject to alteration and changes without prior notice.
- Technical data and descriptions in the documentation are accurate, to the best of our knowledge, but no liabilities for errors, omissions or contingencies arising there from are accepted.
- A circuit breaker must be included in the electrical installation of the building. It must be installed close by the equipment and within easy reach of the operator. It must be marked as the disconnecting device of the equipment: IEC /EN 61010-1 § 6.12.2.1.
- Clean the instrument with a soft dry cloth; do not use abrasives, liquid detergents or solvents.

Indice	Pagina
Introduzione	2
Descrizione	2
Funzione dei tasti frontali	3
LED frontali	3
Modi operativi	4
Messa in tensione	4
Menu principale	5
Accesso tramite password	5
Navigazione fra le pagine del display	6
Tabella delle pagine del display	6
Pagina analisi armonica	9
Pagina forme d'onda	9
Pagine utente	9
Espandibilità	10
Risorse aggiuntive	11
Canali di comunicazione	11
Ingressi, uscite, variabili interne, contatori	11
Soglie limite	12
Variabili da remoto	13
Allarmi utente	13
Logica PLC	13
Test automatico	14
CANbus	14
Porta di programmazione IR	16
Impostazione parametri da PC	16
Impostazione parametri da pannello frontale	17
Tabella dei parametri	18
Allarmi	32
Proprietà degli allarmi	33
Tabella allarmi	33
Descrizione degli allarmi	35
Tabella funzioni ingressi	37
Tabella funzioni uscite	38
Menu comandi	39
Installazione	40
Schemi di connessione	41
Disposizione morsetti	44
Dimensioni meccaniche	44
Foratura pannello	45
Caratteristiche tecniche	46

Index	Page
Introduction	2
Description	2
Keyboard functions	3
Front LED indication	3
Operating modes	4
Power-up	4
Main menu	5
Password access	5
Display page navigation	6
Table of display pages	6
Harmonic analysis page	9
Waveform pages	9
User pages	9
Expandability	10
Additional resources	11
Communication channels	11
Inputs, outputs, internal variables, counters	11
Limit thresholds	12
Remote-controlled variables	13
User alarms	13
PLC Logic	13
Automatic test	14
CAN bus	14
IR programming port	16
Parameter setting through PC	16
Setting of parameters (setup) from front panel	17
Parameter table	18
Alarms	32
Alarm properties	33
Alarm table	33
Alarm description	35
Input function table	37
Output function table	38
Command menu	39
Installation	40
Wiring diagrams	41
Terminal arrangement	44
Mechanical dimensions	44
Panel protection	45
Technical characteristics	46

Introduzione

L'unità di controllo RGK800 è stata progettata incorporando lo stato dell'arte delle funzioni richieste per le applicazioni su gruppi elettrogeni, con e senza controllo automatico della mancanza rete. Realizzato con un contenitore dedicato, di dimensioni estremamente compatte, l' RGK800 unisce il moderno design del frontale alla praticità di montaggio e alla possibilità di espansione sul retro, dove è possibile alloggiare moduli della serie EXP.... Il display grafico LCD consente una interfaccia utente chiara ed intuitiva.

Descrizione

- Controllo del gruppo elettrogeno con gestione automatica della commutazione rete-generatore (RGK800) oppure con gestione avviamento da remoto (RG800SA).
- Display LCD grafico 128x80 pixel, retroilluminato, 4 livelli di grigio.
- 13 tasti per funzioni ed impostazioni.
- Buzzer integrato (disinseribile).
- 10 LED per visualizzazione modalità di funzionamento e stati.
- Testi per misure, impostazioni e messaggi in 5 lingue.
- Bus di espansione con 3 slot per moduli di espansione serie EXP:
 - Interfacce di comunicazione RS232, RS485, USB, Ethernet, Profibus, GSM/GPRS
 - I/O digitali aggiuntivi, uscite statiche o a relè
 - I/O analogici in tensione, corrente, temperatura PT100
- Funzioni di I/O avanzate programmabili.
- Gestione di 4 configurazioni alternative selezionabili da selettore.
- Logica PLC integrata con soglie, contatori, allarmi, stati.
- Allarmi completamente definibili dall'utente.
- Elevata accuratezza delle misure in vero valore efficace (TRMS).
- Ingresso di misura tensioni di rete trifase+neutro.
- Ingresso di misura tensioni generatore trifase+neutro.
- Ingresso di misura correnti carico trifase+neutro o terra.
- Alimentazione da batteria universale 12-24Vdc
- Interfaccia di programmazione ottica frontale, isolata galvanicamente, alta velocità, impermeabile, compatibile con USB e WiFi.
- 4 Ingressi analogici per sensori resistivi:
 - Pressione olio
 - Temperatura liquido di raffreddamento
 - Livello carburante
 - Programmabile
- 9 ingressi digitali:
 - 8 programmabili, negativi
 - 1 per fungo di emergenza, positivo
- 10 uscite digitali:
 - 6 uscite statiche positive protette
 - 3 relè
 - 1 uscita statica impulsiva
- Ingresso pick-up e W per rilevamento velocità motore.
- Interfaccia di comunicazione CAN bus-J1939 per controllo ECU motore.
- Orologio datario con riserva di energia.
- Memorizzazione ultimi 250 eventi.
- Supporto per remotazione allarmi e per remote annunciator.

Introduction

The RGK800 control unit has been designed to offer state-of-the-art functions for genset applications, both with and without automatic mains outage control. Built with dedicated components and extremely compact, the RGK800 combines the modern design of the front panel with practical installation and the possibility of expansion from the rear, where EXP series modules can be slotted. The LCD screen provides a clear and intuitive user interface.

Description

- Genset control with automatic management of mains-generator switching (RGK800) or remote starting management (RG800SA).
- 128x80 pixel, backlit LCD screen with 4 grey levels
- 13 function and setting keys
- Built-in buzzer.
- 10 LEDs indicate operating modes and states
- 5-language text for measurements, settings and messages.
- Expansion bus with 3 slots for EXP series expansion modules:
 - RS232, RS485, USB, Ethernet, Profibus, GSM/GPRS communications interface
 - Additional digital I/O, static or relay outputs
 - PT100 temperature, current, voltage analog I/O.
- Advanced programmable I/O functions.
- 4 alternative functions can be managed, selecting the same with a selector.
- Integrated PLC logic with thresholds, counters, alarms, states.
- Fully user-definable alarms.
- High accuracy TRMS measurement.
- 3-phase + neutral mains voltage reading input.
- 3-phase + neutral genset voltage reading input.
- 3-phase + neutral or earth load currents reading input
- 12-24 VDC universal battery power supply
- Front optical programming interface: galvanically isolated, high speed, waterproof, USB and WiFi compatible.
- 4 analog inputs for resistive sensors:
 - Oil pressure:
 - Coolant temperature
 - Fuel level
 - Programmable
- 9 digital inputs:
 - 8 programmable, negative
 - 1 for emergency-stop pushbutton, positive
- 10 digital outputs:
 - 6 protected positive static outputs
 - 3 relays
 - 1 pulse static output
- Engine speed reading W and pick-up input
- CAN bus-J1939 engine ECU control communications interface.
- Calendar-clock with energy reserve.
- Memorization of last 250 events.
- Support for remote alarms and remote annunciator.



Funzione dei tasti frontali

Tasti OFF, MAN, AUT e TEST - Servono per la scelta della modalità di funzionamento.

Tasti START e STOP - Funzionano solo in modo MAN e servono per avviare e arrestare il gruppo elettrogeno. Premendo brevemente il tasto START si ha un tentativo di avviamento semiautomatico, tenendolo premuto si può prolungare manualmente la durata dell'avviamento. Il LED lampeggiante sul simbolo motore indica motore in moto con allarmi inibiti, acceso fisso al termine del tempo di inibizione allarmi. Il motore può essere fermato immediatamente anche mediante il tasto OFF.

Tasti MAINS e GEN - Funzionano solo in modo MAN e servono per commutare il carico dalla rete al generatore e viceversa. I LED verdi accesi in prossimità dei simboli della rete e generatore indicano le rispettive tensioni disponibili entro i limiti predefiniti. I LED accesi in prossimità dei simboli di commutazione indicano l'avvenuta chiusura dei dispositivi di commutazione, lampeggianti se il segnale di ritorno (feed-back) di effettiva chiusura o apertura dei dispositivi di commutazione non corrispondono allo stato comandato.

Tasto **✓** - Serve per richiamare il menu principale e per confermare una scelta.

Tasti **▲** e **▼** - Servono per scorrere le pagine del display o per selezionare la lista di opzioni di un menu.

Tasto **◀** - Serve per selezionare le misure da Rete o Generatore oppure per decrementare una impostazione.

Tasto **▶** - Serve per scorrere le eventuali sotto-pagine oppure per incrementare una impostazione.

LED frontali

LED OFF, MAN, AUT e TEST (rossi) - Il LED acceso indica la modalità attiva. Se il LED lampeggia significa che il controllo remoto via interfaccia seriale è attivo (e quindi potenzialmente la modalità operativa potrebbe cambiare causa comando remoto).

LED motore in moto (verde) - Indica che il motore è in moto. L'RGK800 rileva lo stato di motore in moto da diversi segnali (tensione/frequenza generatore, D+, AC, W, Pick-up ecc.). Quando uno qualsiasi di questi segnali è presente, il LED si attiva. Se il LED lampeggia significa che il motore è in moto ma le protezioni (allarmi) legati a questo stato non sono ancora abilitate, cosa che avviene tipicamente per alcuni secondi appena dopo l'avviamento.

LED presenza tensione rete / generatore (verdi) - Quando accesi, indicano che tutti i parametri delle rispettive sorgenti di alimentazione rientrano nei limiti. Una qualsiasi anomalia provoca lo spegnimento immediato del LED. Lo stato del LED segue istantaneamente l'andamento delle tensioni/frequenze, senza considerare i ritardi programmati.

LED carico su rete / generatore (gialli) - Indicano che il carico è collegato alla rispettiva sorgente di alimentazione. Si accendono al ricevimento dei segnali di feedback se questi sono programmati, altrimenti all'atto del comando delle uscite. Se lampeggianti indicano che lo stato effettivo del dispositivo di commutazione (letto tramite ingressi di feedback) non corrisponde allo stato comandato dall'RGK800.

LED di allarme (rosso) - Lampeggiante, indica che un allarme è attivo.

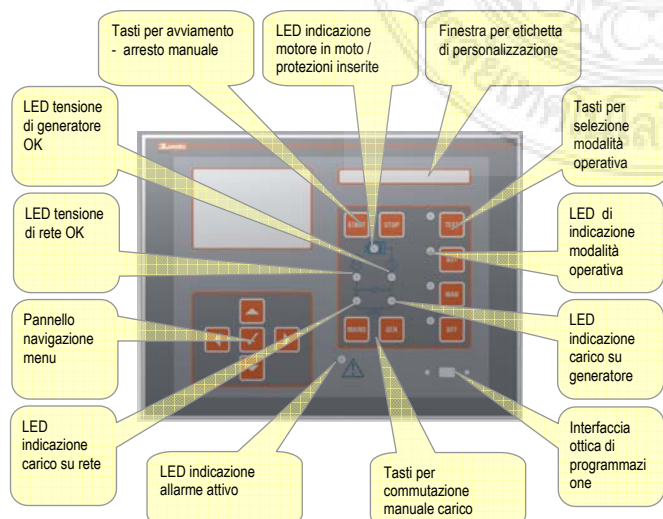

Pannello frontale RGK800

Front keyboard

OFF, MAN, AUT and TEST keys - To choose function mode.

START and STOP keys - Only enabled and used to start and stop genset in MAN mode. Pressing the START key will attempt to start the machine in semiautomatic mode, while holding it down will maintain the start command in manual mode. The LED flashing on the engine symbol indicates the engine is running with the alarms inhibited, and fixed access at the end of the inhibit alarms time. The engine can be stopped immediately with the OFF key.

MAINS and GEN keys - Only enabled in MAN mode and used to switch the load from the mains to the generator and vice versa. The green LEDs lit near the mains and generator symbols indicate the respective voltages available within the preset limits. The LEDs lit near the switching symbols indicate the circuit breakers have been closed. They will flash if the circuit breakers closing or opening feedback signal does not correspond to the state of the command.

Key **✓** - Calls up the main menu and is also used to confirm choices.

Keys **▲** and **▼** - Used to scroll the pages of the display or select the list of options in a menu.

Key **◀** - Used to select the Mains or Generator measurements, or to decrease a number.

Key **▶** - Used to scroll sub-pages or increase a number.

Front LEDs

OFF, MAN, AUT and TEST LED (red) - Lit LED indicates active mode. If the LED flashes, remote control via serial interface is enabled (and therefore the operating mode could be changed by a remote command).

Engine running LED (green) - Indicates the engine is running. The RGK800 detects the state of the engine running on the basis of several signals (generator voltage/frequency, D+, AC, W, Pick-up, etc.). The LED lights when any one of these signals is present. The LED flashes when the engine is running, but the protections (Alarms) associated with this state have not been enabled, which is usually the case for a few seconds after starting.

Mains/generator voltage present LEDs (green) - When lit, these indicate that all the parameters of the respective power sources are within the limits. Any anomaly will immediately turn the LEDs off. The state of the LEDs instantaneously follows the voltage/frequency trend, without programmed delays.

Mains/generator load LEDs (yellow) - Indicate the load is connected to the respective power sources. These light when feedback signals are received if programmed, otherwise they light for output commands. If they are blinking, this indicates that the actual state of the circuit breaker (read through the feedback inputs) does not correspond to the state of the RGK800 command.

Alarm LED (red) - Flashing, indicates an active alarm.

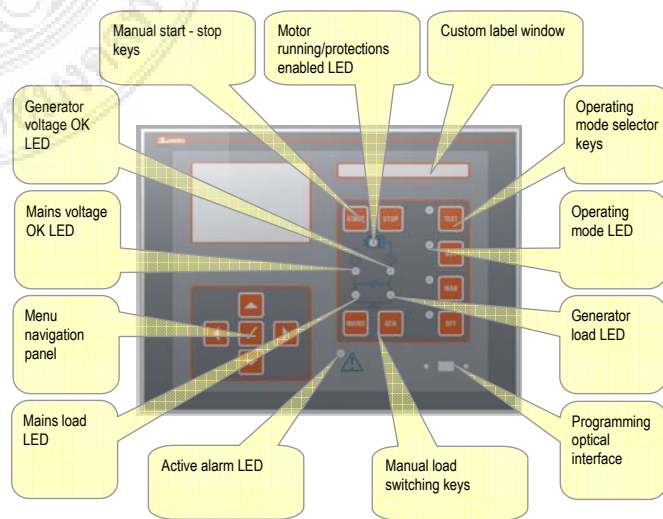

RGK800 front panel

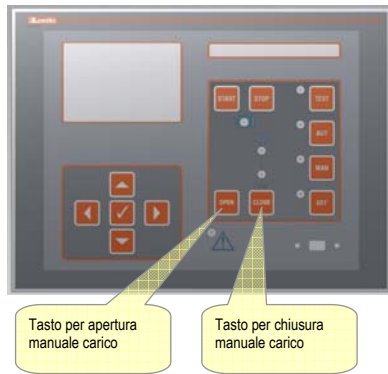

Pannello frontale RGK800SA

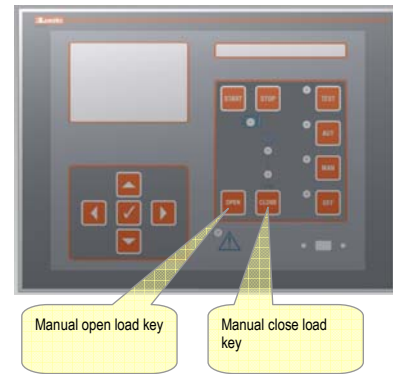

RGK800SA front panel

Modi operativi

Modo OFF - Il motore non viene mai avviato. Passando a questo modo di funzionamento, se il motore è in moto viene arrestato immediatamente. Il relè contattore rete viene chiuso. Questa modalità riproduce lo stato dell'RGK800 quando esso non è alimentato. Per poter accedere alla programmazione dei parametri ed al menu comandi è necessario predisporre il sistema in questa modalità. In modo OFF, la sirena non viene mai attivata.

Modo MAN - Il motore può essere avviato e fermato solo manualmente agendo sui tasti di START e STOP, così pure la commutazione del carico dalla rete al generatore mediante la pressione dei tasti MAINS / GEN e viceversa. All'avviamento, tenendo premuto il pulsante START si ha il prolungamento forzato del tempo di avviamento impostato. Con una singola pressione su START si ha un singolo tentativo di avviamento semiautomatico secondo i tempi programmati.

Modo AUT - Per RGK800, il motore viene avviato automaticamente in caso di assenza rete (fuori dai limiti impostati) e fermato al rientro della stessa, secondo tempi e soglie impostati nel menu *M13 Controllo rete*. Con presenza tensione, la commutazione del carico avviene automaticamente nelle due direzioni.

Per RGK800SA, l'avviamento e l'arresto vengono comandati da remoto tramite un ingresso digitale (avviamento remoto) normalmente comandato da un ATS. La commutazione del carico può essere automatica o comandata da remoto.

Per entrambi i modelli, in caso di mancato avviamento del motore vengono ripetuti i tentativi fino al numero massimo programmato. Il test automatico, se abilitato, viene eseguito alle scadenze prefissate.

Modo TEST - Il motore viene avviato immediatamente anche se non sono presenti le condizioni normalmente necessarie in modo automatico. L'avviamento viene eseguito secondo le modalità del modo automatico. Normalmente non vengono effettuate commutazioni del carico. Per RGK800, in caso di mancanza della rete mentre il sistema è in modo TEST, il carico commuta sul generatore. Se la rete rientra, il carico rimane sul generatore fintanto che non viene cambiata la modalità operativa.

Messa in tensione

- Alla messa in tensione l'apparecchio si pone normalmente in modo OFF.
- Se si necessita che mantenga lo stesso modo di funzionamento precedente lo spegnimento, si deve modificare il parametro P01.03 nel menu *M01 Utilità*.
- L'apparecchio può essere alimentato indifferentemente sia a 12 che a 24VDC, ma necessita della corretta impostazione della tensione di batteria nel menù *M05 Batteria*, diversamente si avrà un'allarme relativo alla tensione di batteria.
- È normalmente indispensabile impostare i parametri del menù *M02 Generale* (tipo di connessione, tensione nominale, frequenza di sistema) e dei menù *M11 Avviamento Motore* e i menu relativi al tipo di motore utilizzato (sensori, CAN ecc.).

Operating modes

OFF mode - The engine will not start. The engine will stop immediately when this mode is selected- The mains contactor is closed. This mode reproduces the state of the RGK800 when it isn't powered. Use this system mode to program the parameters and open the commands menu. The siren is disabled in OFF mode.

MAN Mode - The engine can only be started and stopped manually using the START and STOP keys, as is the case for switching the load from the mains to the generator by pressing the MAINS/GEN keys and vice versa. Holding down the START key extends the set starting time. When START is pressed once, the generator will attempt to start in semiautomatic mode on the basis of the times set.

AUT Mode - The engine of the RGK800 is started automatically in the case of a mains outage (outside the set limits) and stops when the mains parameters are once again within said limits, on the basis of the times set in menu *M13 Mains control*. In the presence of voltage, the load is switched automatically in both directions.

The RGK800SA is started and stopped remotely through a digital input (remote starting) normally controlled by an ATS. The load can be switched automatically or controlled remotely.

For both models, if the engine fails to start, the system continues attempting to start the engine up to the maximum number of programmed attempts. If the automatic test is enabled, it runs at the preset times.

TEST Mode - The engine is started immediately even in the absence of the conditions normally required for the automatic mode. The engine starts in the programmed automatic mode. There is normally no load switching. If there is a mains outage while the RGK800 is in TEST mode, the load is switched to the generator. If mains voltage is restored, the load will remain switched to the generator until the operating mode is changed.

Power-up

- The system normally starts in OFF mode.
- If you want the operating mode used before the system powers down to be maintained, change parameter P01.03 in menu *M01 Utility*.
- The system can be powered at both 12 and 24 VDC, but the correct battery voltage must be set in menu *M05 Battery*, or a battery voltage alarm will be generated.
- The parameters of menu *M02 General* (type of connection, rated voltage, system frequency), menu *M11 Engine Starting*, and the menus for the type of engine used (sensors, CAN, etc.) should normally be set.

Menu principale

- Il menu principale è costituito da un insieme di icone grafiche che permettono l'accesso rapido alle misure ed alle impostazioni.
- Partendo dalla visualizzazione misure normale, premendo il tasto ✓. Il display visualizza il menu rapido.
- Premere ▲ o ▼ per ruotare in senso orario/antiorario fino a selezionare la funzione desiderata. L'icona selezionata viene evidenziata e la scritta nella parte centrale del display indica la descrizione della funzione.
- Premere ✓ per attivare la funzione selezionata.
- Se alcune funzioni non sono disponibili la corrispondente icona sarà disabilitata, cioè visualizzata in colore grigio chiaro.
- etc - Agiscono come scorciatoie che consentono di velocizzare l'accesso alle pagine di visualizzazione misure, saltando direttamente al gruppo di misure selezionato, partendo dal quale ci si potrà spostare avanti e indietro come di consueto.
- - Impostazione del codice numerico che consente l'accesso alle funzioni protette (impostazione dei parametri, esecuzione di comandi).
- - Punto di accesso alla programmazione dei parametri. Vedere il capitolo dedicato.
- - Punto di accesso al menu comandi, dove l'utente abilitato può eseguire una serie di azioni di azzeramento e ripristino.

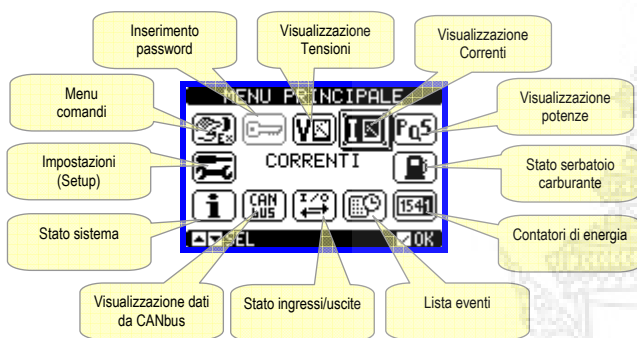

Accesso tramite password

- La password serve per abilitare o bloccare l'accesso al menu di impostazione ed al menu comandi.
- Per gli apparecchi nuovi di fabbrica (default), la password è disabilitata e l'accesso è libero. Se invece le password sono state abilitate, per ottenere l'accesso bisogna prima inserire il relativo codice di accesso numerico.
- Per abilitare l'uso delle password e definire i codici di accesso fare riferimento al menu di impostazione *M03 Password*.
- Esistono due livelli di accesso, a seconda del codice inserito:
 - **Accesso livello utente** – consente l'azzeramento dei valori registrati e la modifica di alcune impostazioni dell'apparecchio.
 - **Accesso livello avanzato** – stessi diritti dell'utente con in più la possibilità di modificare tutte le impostazioni.
- Dalla normale visualizzazione misure, premere ✓ per richiamare il menu principale, quindi selezionare l'icona password e premere ✓.
- Compare la finestra di impostazione password in figura:



- Con i tasti ▲ e ▼ si cambia il valore della cifra selezionata.
- Con i tasti ◀ e ▶ ci si sposta fra le cifre.
- Inserire tutte le cifre della password, quindi spostarsi sull'icona chiave.
- Quando la password inserita corrisponde alla *Password livello Utente* o alla *Password livello Avanzato*, compare il relativo messaggio di sblocco.
- Una volta sbloccata la password, l'accesso rimane abilitato fino a che:
 - l'apparecchio viene spento.
 - l'apparecchio viene resettato (in seguito all'uscita dal menu impostazioni).
 - trascorrono più di 2 minuti senza che l'operatore tocchi alcun tasto.
- Con il tasto ✓ si abbandona l'impostazione password e si esce.

Main menu

- The main menu is made up of a group of graphic icons (shortcuts) that allow rapid access to measurements and settings.
- Starting from normal viewing, press ✓ key. The main menu screen is displayed.
- Press ▲ ▼ to rotate clockwise/counter clockwise to select the required function. The selected icon is highlighted and the central part of the display shows the description of the function.
- Press ✓ to activate the selected function.
- If some functions are not available, the correspondent icon will be disabled, that is shown in a light grey colour.
- etc. - Shortcuts that allow jumping to the first page of that group. Starting from that page it is still possible to move forward-backward in the usual way.
- - Opens the password entry page, where it is possible to specify the numeric codes that unlock protected functions (parameter setting, commands menu).
- - Access point to the setup menu for parameter programming. See dedicated chapter.
- - Access point to the commands menu, where the authorised user can execute some clearing-restoring actions.

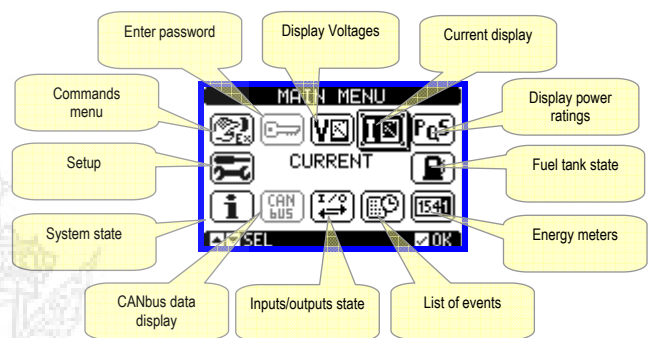

Password access

- The password is used to enable or lock the access to setting menu (setup) and to commands menu.
- For brand-new devices (factory default), the password management is disabled and the access is free. If instead the passwords have been enabled and defined, then to get access, it is necessary to enter the password first, specifying the numeric code through the keypad.
- To enable password management and to define numeric codes, see setup menu.
- There are two access levels, depending on the code entered:
 - **User-Level access** – Allows clearing of recorded values and the editing of a restricted number of setup parameters.
 - **Advanced access level** – Same rights of the user access plus full settings editing-restoring.
- From normal viewing, press ✓ to recall main menu, select the password icon and press ✓.
- The display shows the screen in picture:



- Keys ▲ and ▼ change the selected digit
- Keys ◀ and ▶ move through the digits.
- Enter all the digits of the numeric code, then move on the key icon.
- If the password code entered matches the *User access code* or the *Advanced access code*, then the correspondent unlock message is shown.
- Once unlocked the password, the access rights last until:
 - the device is powered off.
 - the device is reset (after quitting the setup menu).
 - the timeout period of two minutes elapses without any keystroke.
- To quit the password entry screen press ✓ key.

Navigazione fra le pagine display

- I tasti ▲ e ▼ consentono di scorrere le pagine di visualizzazione misure una per volta. La pagina attuale è riconoscibile tramite la barra del titolo.
- Alcune delle misure potrebbero non essere visualizzate in funzione della programmazione e del collegamento dell'apparecchio (ad esempio se non è impostato un sensore di livello del carburante, la relativa pagina non viene visualizzata).
- Per RGK800, su alcune pagine è possibile commutare la visualizzazione dalle misure di rete a quelle di generatore e viceversa premendo il tasto ◀. La sorgente visualizzata è sempre indicata, o al centro della pagina oppure con le icone R e G nella status bar.
- Per alcune pagine sono disponibili delle sotto-pagine accessibili tramite il tasto ▶ (ad esempio per visualizzare tensioni e correnti sotto forma di barre grafiche).
- L'utente ha la possibilità di specificare su quale pagina e su quale sottopagina il display deve ritornare automaticamente dopo che è trascorso un tempo senza che siano premuti dei tasti.
- Volendo è anche possibile programmare il sistema in modo che la visualizzazione resti sempre nella posizione in cui è stata lasciata.
- Per l'impostazione di queste funzioni vedere menu M01 – Utilità.

Tabella delle pagine del display

PAGINE	ESEMPIO
Tensioni concatenate Tensioni di fase Correnti ... THD tensioni L-L THD tensioni L-N THD correnti	
Tensioni L-L / Correnti Tensioni L-N / Correnti	
Potenza attiva Potenza reattiva Potenza apparente Fattore di potenza	
Contatori di energia	
Riassunto misure elettriche	

Display page navigation

- Keys ▲ and ▼ scroll through the measurements pages one by one. The title bar shows the current page.
- Some measurements may not be shown depending on the system programming and connections (for example if a fuel sensor isn't set, the relevant page will not be shown).
- On some pages of the RGK800, the display can be switched from the mains measurements to the generator measurements and vice versa with key ◀. The source displayed is always indicated, either in the middle of the page or by the icons M and G in the status bar.
- Sub-pages, which can be opened with key ▶, are also available on some pages (displaying voltages and currents in the form of bar graphs, for example).
- The user can specify which page and which sub-page the display should return to automatically when no keys have been pressed for a certain time.
- The system can also be programmed so the display remains where it was last.
- You can set this function in menu M01 – Utility.

Table of display pages

PAGES	EXAMPLE
Line-to-line voltages Phase voltages Current ... L-L voltage THD L-N voltage THD Current THD	
L-L Voltages/Currents L-N Voltages/Currents	
Active power Reactive power Apparent power Power factor	
Energy meters	
Summary of electrical measurements	

Velocità motore	<p>Nota: Da questa pagina è possibile acquisire automaticamente il rapporto fra giri e frequenza del segnale W. Vedere descrizione parametro P07.02.</p> <p>Indicatore grafico velocità</p> <p>Limite minimo impostato</p> <p>Limite massimo impostato</p>
Livello carburante	<p>Barra livello attuale</p> <p>Capacità totale serbatoio</p> <p>Carburante disponibile</p> <p>Quantità al riempimento</p> <p>Comando manuale pompa</p> <p>Stato pompa rabbocco</p>
Autonomia carburante	<p>Autonomia residua al consumo attuale da CAN</p> <p>Consumo istantaneo attuale da CAN</p> <p>Autonomia residua al consumo massimo dichiarato</p> <p>Consumo massimo dichiarato del motore</p>
Corrente guasto a terra	<p>Valore assoluto attuale</p> <p>Percentuale rispetto a valore intervento</p>
Protezione termica generatore	<p>Percentuale rispetto a valore intervento</p>
Ore motore e Contatori lavoro	<p>Ore lavoro motore totali</p> <p>Ore lavoro motore parz.</p> <p>Ore carico alimentato</p> <p>Contatore tentativi di avviamento</p> <p>Percentuale di tentativi riusciti</p> <p>Contatore commutazioni carico</p>
Intervalli manutenzione	<p>Codice intervallo manutenzione</p> <p>Tempo mancante alla scadenza</p> <p>Data ultima manutenzione</p> <p>Intervallo programmato</p>
Noleggio	<p>Tempo mancante alla scadenza</p> <p>Data inizio noleggio</p> <p>Durata programmata</p>

Engine speed	<p>Note: From this page it is possible to acquire automatically the ratio between RPM and W frequency. See description of parameter P07.02.</p> <p>Speed indicator</p> <p>Min. limit</p> <p>Max. limit</p>
Fuel level status	<p>Current level bar</p> <p>Total tank capacity</p> <p>Available fuel</p> <p>Quantity after filling</p> <p>Man. pump command</p> <p>Filling pump state</p>
Fuel autonomy	<p>Residual autonomy with present fuel rate from CAN</p> <p>Present fuel rate from CAN</p> <p>Residual autonomy with maximum fuel rate</p> <p>Maximum declared engine fuel rate</p>
Earth fault current	<p>Present absolute value</p> <p>Percentage of intervention value</p>
Generator thermal protection	<p>Percentage of intervention value</p>
Engine hour and work counters	<p>Total engine work hours</p> <p>Part. engine work hours</p> <p>Load supplied hours</p> <p>Attempted starts counter</p> <p>Percentage successful attempts</p> <p>Load switching counter</p>
Maintenance intervals	<p>Maintenance interval code</p> <p>Time to next service</p> <p>Date of last service</p> <p>Programmed interval</p>
Rent	<p>Time to expiry</p> <p>Rent start date</p> <p>Programmed duration</p>

Lista eventi	<p>Data e ora evento</p> <p>Codice evento</p> <p>Descrizione evento</p>
Configurazioni alternative	<p>Dati configurazione attuale</p> <p>Numero configuraz. selezionata</p>
Stato I/O	<p>Stato I/O digitali. In reverse = attivato</p>
Orologio datario	
Pagina informativa	
Informazioni di sistema	<p>Livello di revisione Software Hardware Parametri</p> <p>Nome del generatore impostato</p> <p>Temperatura interna della scheda</p>

List of events	<p>Date and time of intervention</p> <p>Event code</p> <p>Description of event</p>
Alternative configurations	<p>Present config. data</p> <p>Selected config. number</p>
I/O state	<p>Digital I/O state In reverse = enabled</p>
Real time calendar clock	
Info page	
System info	<p>Software Hardware Parameters revision level</p> <p>Generator set name</p> <p>internal board temp.</p>

Nota: Alcune delle pagine elencate sopra potrebbero non essere visualizzate, se la relativa funzione non è abilitata. Ad esempio se non viene programmata la funzione noleggio, la corrispondente pagina non viene visualizzata.

Note: Some of the pages listed above may not be displayed if the relevant function is disabled. For example, if the rent function isn't programmed, the corresponding page won't be shown.

Pagina analisi armonica

- Nell'RGK800 è possibile abilitare il calcolo e la visualizzazione dell'analisi armonica FFT fino al 31.mo ordine delle seguenti misure:
 - tensioni concatenate
 - tensioni di fase
 - correnti
- Per abilitare l'analisi armonica, impostare il parametro P23.14.
- Per ognuna di queste misure è disponibile una pagina che rappresenta graficamente il contenuto armonico (spettro) tramite un istogramma a barre.
- Ciascuna colonna rappresenta un ordine delle armoniche, pari e dispari. La prima colonna rappresenta il contenuto armonico totale (THD).
- Ciascuna colonna dell'istogramma è poi divisa in tre parti che rappresentano il contenuto armonico delle tre fasi L1,L2,L3.
- Il valore del contenuto armonico è espresso in percentuale riferita alla ampiezza della armonica fondamentale (frequenza di sistema).
- E' possibile visualizzare il valore del contenuto armonico in forma numerica, selezionando l'ordine desiderato tramite ◀ e ▶ . In basso vengono visualizzati una freccetta che punta alla colonna e il contenuto armonico percentuale delle tre fasi.
- La scala verticale del grafico viene selezionata automaticamente fra quattro valori di fondoscala, in base alla colonna con il valore più alto.

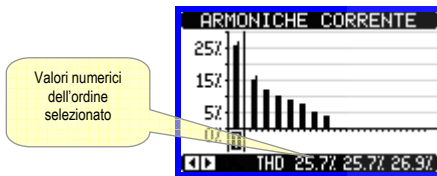

Pagina forme d'onda

- Questa pagina rappresenta graficamente la forma d'onda dei segnali di tensione e di corrente letti dall'RGK800.
- E' possibile vedere una fase per volta, selezionandola con i tasti ◀ e ▶ .
- La scala verticale (ampiezza) è regolata automaticamente in modo da visualizzare al meglio possibile il segnale.
- Sull'asse orizzontale (tempo) vengono visualizzati 2 periodi consecutivi riferiti alla frequenza attuale.
- Il grafico viene aggiornato automaticamente ogni 1 s circa.

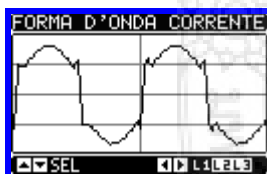

Pagine utente

- L'utente ha la possibilità di creare un numero massimo di 4 pagine personalizzate.
- Queste pagine possono contenere 3 misure ciascuna, scelte liberamente fra quelle disponibili sull'RGK800.
- Il titolo della pagina utente può essere specificato liberamente dall'utente.
- Le pagine utente sono posizionate in modo da poter essere raggiunte facilmente partendo dalla prima pagina e premendo il tasto ▲ .
- Come per tutte le altre pagine, è poi possibile programmare il sistema per posizionare il display su una delle pagine utente dopo che per un certo tempo non sono stati premuti dei tasti.
- Per l'impostazione delle pagine utente vedere l'apposito menu M26 *Pagine utente* nel capitolo impostazione parametri.

Harmonic analysis page

- In the RGK800 it is possible to enable the calculation of the FFT harmonic analysis up to the 31st order of the following measurements:
 - phase-to-phase voltages
 - phase-to-neutral voltages
 - currents
- To enable the harmonic analysis, set parameter P23.14.
- For each of these measurements, there is a display page that graphically represents the harmonic content (spectrum) through a bar graph.
- Every column is related to one harmonic order, even and odd. The first column shows the total harmonic distortion (THD).
- Every histogram bar is then divided into three parts, one each phase L1,L2, L3.
- The value of the harmonic content is expressed as a percentage with respect to the fundamental (system frequency).
- It is possible to show the harmonic content in numeric format, selecting the required order through ◀ and ▶ . The lower part of the screen will display a little arrow that points to the selected column, and the relative percentage value of the three phases.
- The vertical scale of the graph is automatically selected among four full-scale values, depending on the column with the highest value.

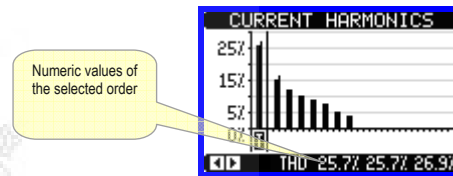

Waveform page

- This page graphically views the waveform of the voltage and current signals read by the RGK800.
- It is possible to see one phase at a time, selecting it with ↻ key.
- The vertical scale (amplitude) is automatically scaled in order to fit the waveform on the screen in the best possible way.
- The horizontal axis (time) shows two consecutive periods referred to the fundamental frequency.
- The graph is automatically updated about every 1s.

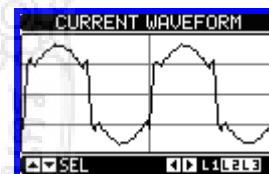

User pages

- The user can create a maximum of 4 customised display pages.
- Each of these pages can view 3 measurements, freely chosen among the available readings of the RGK800.
- The title of the page can be freely programmed by the user.
- The user pages are placed in a position that allows to reach them easily starting from the first page, by pressing button ▲ .
- Like all other pages, it is possible to set the system to return automatically to the user page after a time has elapsed without keystrokes.
- To define the user page, see the dedicated menu M26 *User pages* in the parameter setup chapter.

Espandibilità

- Grazie al suo bus di espansione, l' RGK800 può essere espanso con dei moduli aggiuntivi della serie EXP...
- E' possibile installare un massimo di 3 moduli EXP... contemporaneamente.
- I moduli EXP... supportati dal RGK800 si dividono nelle seguenti categorie:
 - moduli di comunicazione
 - moduli di I/O digitale
 - moduli di I/O analogico.
- Per inserire un modulo di espansione:
 - togliere l'alimentazione all' RGK800
 - rimuovere uno dei coperchi protettivi degli slot di espansione
 - inserire il gancio superiore del modulo nella apposita feritoia a sinistra nello slot
 - ruotare il modulo verso destra inserendo il connettore sul bus
 - premere fino a che l'apposita clip sul lato inferiore del modulo si aggancia a scatto.
- Salvo diversa indicazione, l' ordine di inserimento dei moduli è libero.
- Per migliorare la sicurezza di fissaggio dei moduli di espansione in applicazioni sottoposte a forti vibrazioni, è possibile montare l'apposito accessorio di blocco dei moduli, incluso nella confezione.
- Per montare questo accessorio:
 - rimuovere le due viti di destra con un cacciavite Torx T7
 - posizionare il ponte sopra i moduli già agganciati
 - riavvitare le viti nella loro sede originale.

Expandability

- Thanks to expansion bus, the RGK800 can be expanded with EXP... series modules.
- It is possible to connect a maximum of 3 EXP... modules at the same time.
- The supported EXP modules can be grouped in the following categories:
 - communication modules
 - digital I/O modules
 - Analog I/O modules.
- To insert an expansion module:
 - remove the power supply to RGK800
 - remove the protecting cover of one of the expansion slots
 - insert the upper hook of the module into the fixing hole on the left of the expansion slot
 - rotate right the module body, inserting the connector on the bus
 - push until the bottom clip snaps into its housing.
- Unless otherwise specified, the modules can be inserted in any sequence.
- In applications subject to considerable vibrations, the expansion modules can be held securely in place with the special module bridge clamp accessory, included in the pack.
- To fit this accessory:
 - remove the two right screws with a Torx T7 screwdriver
 - position the bridge over the connected modules
 - screw the screws back in place again.



- Quando un RGK800 viene alimentato, riconosce automaticamente i moduli EXP ad esso collegati.
- Se la configurazione del sistema è diversa rispetto all'ultima rilevata (è stato aggiunto o rimosso un modulo), l'unità base chiede all'utente di confermare la nuova configurazione. In caso di conferma la nuova configurazione verrà salvata e diventerà effettiva, altrimenti ad ogni messa in tensione verrà segnalata la discordanza.
- La configurazione attuale del sistema è visualizzata nella apposita pagina del display (moduli espansione), dove si vedono il numero, il tipo e lo stato dei moduli collegati.
- La numerazione degli I/O viene elencata sotto ogni modulo.
- Lo stato (attivato/disattivato) degli I/O e dei canali di comunicazione viene evidenziato con la scritta in negativo.

- When the RGK800 is powered on, it automatically recognises the EXP modules that have been mounted.
- If the system configuration has changed with respect to the last saved, (one module has been added or removed), the base unit asks the user to confirm the new configuration. In case of confirmation, the new configuration will be saved and will become effective, otherwise the mismatch will be shown at every subsequent power-on of the system.
- The actual system configuration is shown in the dedicated page of the display (expansion modules), where it is possible to see the number, the type and the status of the modules.
- The I/O numbering is shown under each module.
- The status (energised/de-energised) of every single I/O and communication channel is highlighted in reverse

Stato delle porte sulla unità base:
COM1 = RS485
EMER = emergenza
CAN = CAN bus
IR = porta programmaz.

MODULI DI ESPANSIONE	
RGK 800	RS 232
COM1	0012
EMER	
CAN	
IR	
SEL	

Tipo dei moduli di espansione

State of the ports on the base unit.
COM1 = RS485
EMER = emergency
CAN = CAN bus
IR = programming port.

EXPANSION MODULES	
RGK 800	RS 232
COM1	0012
EMER	
CAN	
IR	
SEL	

Type of expansion modules

Number and state of additional resources

Risorse aggiuntive

- I moduli di espansione forniscono delle risorse aggiuntive che possono essere sfruttate tramite gli opportuni menu di impostazione.
- I menu di impostazione che riguardano le espansioni sono disponibili anche se i moduli non sono fisicamente presenti.
- Dato che è possibile aggiungere più moduli della stessa tipologia (ad esempio due interfacce di comunicazione) i relativi menu di impostazione sono multipli, identificati da un numero progressivo.
- Di seguito una tabella che indica quanti moduli di ogni tipo possono essere montati contemporaneamente. Il numero totale di moduli deve essere ≤ 3 .

TIPO MODULO	CODICE	FUNZIONE	Nr. MAX
COMUNICAZIONE	EXP 10 10	USB	2
	EXP 10 11	RS-232	2
	EXP 10 12	RS-485	2
	EXP 10 13	Ethernet	1
	EXP 10 14	Profibus® DP	1
	EXP 10 15	GSM-GPRS	1
I/O DIGITALI	EXP 10 00	4 INGRESSI	2
	EXP 10 01	4 USCITE STATICHE	2
	EXP 10 02	2 INGRESSI + 2 USCITE ST.	3
	EXP 10 03	2 RELE'	3
I/O ANALOGICI	EXP 10 04	2 INGRESSI ANALOGICI	3
	EXP 10 05	2 USCITE ANALOGICHE	3

Canali di comunicazione

- All' RGK800 è possibile connettere un massimo di 2 moduli di comunicazione, denominati COMn, oltre alla RS-485 di base. Il menu di impostazione comunicazioni prevede quindi tre sezioni (n=1 ... 3) di parametri per l'impostazione delle porte di comunicazione.
- La porta RS485 montata di serie sulla scheda base è mappata come COM1, quindi gli eventuali canali aggiuntivi saranno denominati COM2 e COM3.
- I canali di comunicazione sono completamente indipendenti, sia dal punto di vista hardware (tipo di interfaccia fisica) che dal punto di vista del protocollo di comunicazione.
- I canali di comunicazione possono funzionare contemporaneamente.
- Attivando la funzione Gateway, è possibile avere un RGK800 equipaggiato con una porta Ethernet ed una porta RS485, che fa da 'ponte' verso altri RGK dotati della sola porta RS-485, in modo da ottenere un risparmio (1 solo punto di accesso Ethernet).
- In questa rete, l' RGK dotato della porta ethernet avrà il parametro della funzione Gateway impostato su ON per entrambi i canali di comunicazione (due tra COM1, COM2 e COM3) mentre gli altri RGK saranno configurati normalmente con Gateway = OFF.

Ingressi, uscite, variabili interne, contatori, ingressi analogici

- Gli ingressi e le uscite sono identificati da una sigla e da un numero progressivo. Ad esempio gli ingressi digitali sono denominati INPx, dove x rappresenta il numero dell'ingresso. Allo stesso modo, le uscite digitali sono denominate OUTx.
- La numerazione degli ingressi / uscite si basa semplicemente sulla posizione di montaggio dei moduli di espansione, con una numerazione progressiva dall'alto verso il basso.
- E' possibile gestire fino a 6 ingressi analogici (AINx) provenienti da sensori esterni (misure di temperatura, consumo, pressione, portata ecc). Il valore letto dagli ingressi analogici può essere convertito in qualsiasi unità ingegneristica, visualizzato sul display e reso disponibile sul bus di comunicazione. Le grandezze lette attraverso gli ingressi analogici sono visualizzate sulla apposita pagina. Su di esse possono essere applicate delle soglie limite LIMx, che a loro volta possono essere collegate ad una uscita interna od esterna, o inserite in una funzione

Additional resources

- The expansion modules provide additional resources that can be used through the dedicated setup menus.
- The setup menus related to the expansions are always accessible, even if the expansion modules are not physically fitted.
- Since it is possible to add more than one module of the same typology (for instance two communication interfaces), the setup menus are multiple, identified by a sequential number.
- The following table indicates how many modules of each group can be mounted at the same time. The total number of modules must be less or equal than 3.

MODULE TYPE	CODE	FUNCTION	MAX Nr.
COMMUNICATION	EXP 10 10	USB	2
	EXP 10 11	RS-232	2
	EXP 10 12	RS-485	2
	EXP 10 13	Ethernet	1
	EXP 10 14	Profibus® DP	1
	EXP10 15	GSM-GPRS	1
DIGITAL I/O	EXP 10 00	4 INPUTS	2
	EXP 10 01	4 STATIC OUTPUTS	2
	EXP 10 02	2 INPUTS + 2 ST. OUTPUTS	3
	EXP 10 03	2 RELAYS	3
ANALOG I/O	EXP 10 04	2 ANALOG INPUTS	3
	EXP 10 05	2 ANALOG OUTPUTS	3

Communication channels

- The RGK800 supports a maximum of 2 communication modules, indicated as COMn, in addition to the base RS-485. The communication setup menu is thus divided into three sections (n=1 ... 3) of parameters for the setting of the ports.
- The built-in RS-485 interface on the main board is mapped as COM1, thus the eventual additional channels will be called COM2 and COM3.
- The communication channels are completely independent, both for the hardware (physical interface) and for the communication protocol.
- The two channels can communicate at the same time.
- Activating the Gateway function it is possible to use a RGK800 with both an Ethernet port and a RS485 port, that acts as a bridge over other RGKs equipped with RS-485 only, in order to achieve a more economic configuration (only one Ethernet port).
- In this network, the RGK with Ethernet port will be set with both communication channels (two among COM1, COM2 and and COM3) with Gateway function set to ON, while the other RGKs will be configured normally with Gateway = OFF.

Inputs, outputs, internal variables, counters, analog inputs

- The inputs and outputs are identified by a code and a sequence number. For instance, the digital inputs are identified by code INPx, where x is the number of the input. In the same way, digital outputs are identified by code OUTx.
- The sequence number of I/Os is simply based on their mounting position, with a progressive numbering from top to bottom.
- It is possible to manage up to 6 analog inputs (AINx), connected to external analog sensors (temperature, pressure, flow etc). The value read from the sensors can be scaled to any unit of measure, visualized on the display and transmitted on the communication bus. The value read from analog inputs is shown on the dedicated display page. They can be used to drive LIMx limit thresholds, that can be linked to an internal or external output, or used in a PLC logic function.
- The expansion I/O numbering starts from the last I/O installed on the base unit. For example, with INP1...INP8 digital inputs on the base unit, the first

logica PLC.

- La numerazione degli I/O di espansione parte a cominciare dall'ultimo I/O montato sulla unità base. Ad esempio, per gli ingressi digitali, INP1...INP8 sulla unità base, e quindi il primo ingresso digitale sui moduli di espansione sarà denominato INP9. Vedere la seguente tabella per la numerazione degli I/O:

COD	DESCRIZIONE	BASE	EXP
INPx	Ingressi digitali	1...8	9...16
OUTx	Uscite digitali	1...10	11...16
COMx	Porte di comunicazione	1	2...3
AINx	Ingressi analogici	-	1...6
AOUx	Uscite analogiche	-	1...6
RALx	Relè remoti per allarmi /stati	-	1...24

- Allo stesso modo degli ingressi/uscite, esistono delle variabili interne (bit) che possono essere associate alle uscite o combinate fra loro. Ad esempio si possono applicare delle soglie limite alle misure effettuate dal sistema (tensione, corrente etc.). In questo caso la variabile interna, denominata LIMx, sarà attivata quando la misura risulta essere fuori dai limiti definiti dall'utente tramite il relativo menu di impostazione.
- Inoltre sono disponibili fino a 8 contatori (CNT1...CNT8) che possono conteggiare impulsi provenienti dall'esterno (quindi da ingressi INPx) oppure il numero di volte per cui si è verificata una determinata condizione. Ad esempio definendo una soglia LIMx come sorgente di conteggio, sarà possibile contare quante volte una misura ha superato un certo valore.
- Di seguito una tabella che raccoglie tutte le variabili interne gestite dall'RGK800, con evidenziato il loro range (numero di variabili per tipo).

COD.	DESCRIZIONE	RANGE
LIMx	Soglie limite sulle misure	1...16
REMx	Variabili controllate da remoto	1...16
UAX	Allarmi utente	1...8
PULx	Impulsi sul consumo di energia	1...6
CNTx	Contatori programmabili	1...8
PLCx	Variabili della logica PLC	1...32

Soglie limite (LIMx)

- Le soglie limite LIMn sono delle variabili interne il cui stato dipende dalla fuoriuscita dai limiti definiti dall'utente da parte di una misura fra quelle effettuate dal sistema (esempio: potenza attiva totale superiore a 25kW).
- Per velocizzare l'impostazione delle soglie, che possono spaziare in un range estremamente ampio, ciascuna di esse va impostata con un valore base + un coefficiente moltiplicativo (esempio: 25 x 1k = 25000).
- Per ogni LIM sono disponibili due soglie (superiore ed inferiore). La soglia superiore deve essere sempre impostata ad un valore maggiore di quella inferiore.
- il significato delle soglie dipende dalle seguenti funzioni:

Funzione Min: con la funzione Min la soglia inferiore è d'intervento quella superiore di ripristino. Quando il valore della misura selezionata è sotto il limite inferiore, dopo il ritardo impostato si ha l'attivazione della soglia. Quando il valore della misura è maggiore della soglia superiore, dopo il ritardo impostato si ha il ripristino.

Funzione Max: con la funzione Max la soglia superiore è d'intervento quella inferiore di ripristino. Quando il valore della misura selezionata è maggiore della superiore, dopo il ritardo impostato si ha l'attivazione della soglia. Quando il valore della misura è minore della soglia inferiore, dopo il ritardo impostato si ha il ripristino.

Funzione Min+Max: con la funzione Min+Max le soglie inferiore e superiore sono entrambe d'intervento. Quando il valore della misura selezionata è minore della soglia inferiore o maggiore della soglia superiore, dopo i rispettivi ritardi si ha l'intervento della soglia. Quando il valore della misura rientra nei limiti si ha il ripristino immediato

- L'intervento può significare eccitazione o diseccitazione del limite LIMn a seconda dell'impostazione.
- Se il limite LIMn è impostato con memoria, il ripristino è manuale e può

digital input on the expansion modules will be INP9. See the following table for the I/O numbering:

COD	DESCRIZIONE	BASE	EXP
INPx	Digital Inputs	1...8	9...16
OUTx	Digital Outputs	1...10	11...16
COMx	Communication ports	1	2...3
AINx	Analog Inputs	-	1...8
AOUx	Analog Outputs	-	1...8
RALx	Remote relays for Alarm / status	-	1...24

- In a similar way, there are some internal bit-variables (markers) that can be associated to the outputs or combined between them. For instance, it is possible to apply some limit thresholds to the measurements done by the system (voltage, current, power, etc.). In this case, an internal variable named LIMx will be activated when the measurements will go outside the limits defined by the user through the dedicated setting menu.
- Furthermore, there are up to 8 counters (CNT1..CNT8) that can count pulses coming from an external source (through a digital input INPx) or the number of times that a certain condition as been verified. For instance, defining a limit threshold LIMx as the count source, it will be possible to count how many times one measurement has exceeded a certain limit.
- The following table groups all the I/O and the internal variables managed by the RGK800.

CODE	DESCRIPTION	RANGE
LIMx	Limit thresholds	1...16
REMx	Remote-controlled variables	1...16
UAX	User alarms	1...8
PULx	Energy consumption pulses	1...6
CNTx	Programmable counters	1...8
PLCx	PLC logic variables	1...32

Limit thresholds (LIMx)

- The LIMn thresholds are internal variables whose status depends on the out-of-limits of one particular measurement set by the user (e.g. total active power higher than 25kW) among all those measured.
- To make the setting of the thresholds easier, since the limits can span in a very wide range, each of them can be set using a base number and a multiplier (for example: 25 x 1k = 25000).
- For each LIM, there are two thresholds (upper and lower). The upper threshold must always be set to a value higher than the lower threshold.
- The meaning of the thresholds depends on the following functions:

Min function: the lower threshold defines the trip point, while the upper threshold is for the resetting. The LIM trips when the selected measurement is less than the Lower threshold for the programmed delay. When the measured value becomes higher than the upper setpoint, after the set delay, the LIM status is reset.

Max function: the upper threshold defines the trip point, while the lower threshold is for the resetting. The LIM trips when the selected measurement is more than upper threshold for the programmed delay. When the measured value decreases below the lower setpoint, after the delay, the LIM status is reset.

Max+Min function: both thresholds are for tripping. When the measured value is less than lower or more than upper setpoints, then, after the respective delays, the LIM will trip. When the measured value returns within the limits, the LIM status will be immediately reset.

- Trip denotes either activation or de-activation of the LIM variable, depending on 'Normal status' setting.
- If the LIMn latch is enabled, the reset can be done only manually using the dedicated command in the commands menu.

essere effettuato tramite il comando apposito nel menu comandi.

- Vedere il menu di impostazione M24.

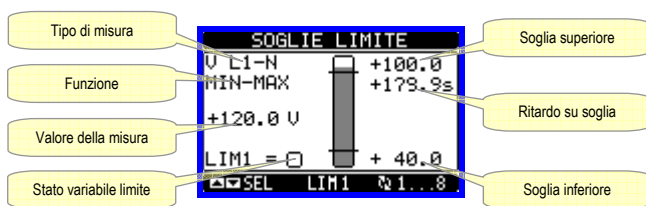

Variabili da remoto (REMX)

- RGK800 ha la possibilità di gestire un massimo di 8 variabili comandate da remoto (REM1...REM8).
- Si tratta di variabili il cui stato può essere modificato a piacere dall'utente tramite il protocollo di comunicazione e che possono essere utilizzate in abbinamento alle uscite, alla logica Booleana etc.
- Esempio: usando una variabile remota (REMX) come sorgente di una uscita (OUTx) sarà possibile attivare e disattivare liberamente un relè tramite il software di supervisione. Questo consentirebbe di utilizzare i relè di uscita del RGK800 per comandare dei carichi ad esempio illuminazione o altro.
- Un altro utilizzo delle variabili REM può essere quello di abilitare o disabilitare determinate funzioni da remoto, inserendole in una logica Booleana in AND con ingressi o uscite.

Allarmi utente (UAx)

- L'utente ha la possibilità di definire un massimo di 8 allarmi programmabili (UA1...UA8).
- Per ciascun allarme è possibile stabilire:
 - la *sorgente*, cioè la condizione che genera l'allarme
 - il *testo* del messaggio che deve comparire sul display quando questa condizione si verifica
 - le *proprietà* dell'allarme (come per gli allarmi standard), cioè in che modo esso interagisce con il controllo del gruppo elettrogeno.
- La condizione che genera l'allarme può essere ad esempio il superamento di una soglia. In questo caso la sorgente sarà una delle soglie limite LIMx.
- Se invece l'allarme deve essere visualizzato in conseguenza dell'attivazione di un ingresso digitale esterno, allora la sorgente sarà un INPx.
- Con lo stesso criterio è possibile abbinare ad un allarme anche condizioni complesse risultanti dalla combinazione logica Booleana di ingressi, soglie, etc. In questo caso si utilizzeranno le variabili PLCx.
- Per ciascun allarme l'utente ha la possibilità di definire un messaggio liberamente programmabile che comparirà sulla finestra pop-up degli allarmi.
- Per gli allarmi utente è possibile definire le proprietà con lo stesso modo utilizzato per gli allarmi normali. Sarà quindi possibile decidere se un determinato allarme deve fermare il motore, suonare la sirena, chiudere l'uscita di allarme globale ecc. Vedere il capitolo *Proprietà degli allarmi*.
- In caso di presenza contemporanea di più allarmi essi vengono mostrati a rotazione e ne viene indicato il numero totale.
- Per azzerare un allarme che è stato programmato con memoria, utilizzare l'apposito comando nel menu comandi.
- Per la definizione degli allarmi vedere menu di impostazione M32.

Logica PLC (PLCx)

- Tramite il software *Customization manager* è possibile impostare un programma *ladder* per realizzare una logica PLC interna all'RGK, in modo da poter creare liberamente qualsiasi funzione sia necessaria alle applicazioni accessorie del gruppo elettrogeno.
- Nella logica del programma è possibile inserire tutte le variabili gestite internamente dall'RGK800, quali ingressi (INPx), soglie limite (LIMx), variabili remote (REMX), stati del controller (RALx) eccetera.
- I risultati della elaborazione dei vari rami della logica ladder vengono memorizzati in variabili interne (PLCx) che possono essere poi usate per comandare delle uscite dell'RGK800, oppure come memorie di appoggio per costruire una logica più complessa, oppure ancora per

- See setup menu M24.

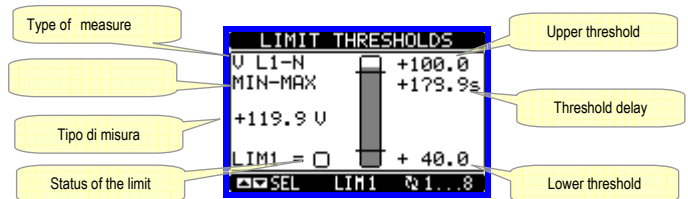

Remote-controlled variables (REMX)

- RGK800 can manage up to 8 remote-controlled variables (REM1...REM8).
- Those are variables which status can be modified by the user through the communication protocol and that can be used in combination with outputs, Boolean logic, etc.
- Example: using a remote variable (REMX) as a source for an output (OUTx), it will be possible to freely energise or de-energise one relay through the supervision software. This allows to use the RGK800 relays to drive lighting or similar loads.
- Another possible use of REM variables is to enable/disable other functions remotely, inserting them into a Boolean logic in AND with inputs or outputs.

User Alarms (UAx)

- The user has the possibility to define a maximum of 8 programmable alarms (UA1...UA8).
- For each alarm, it is possible to define:
 - the *source* that is the condition that generates the alarm,
 - the *text* of the message that must appear on the screen when this condition is met.
 - The *properties* of the alarm (just like for standard alarms), that is in which way that alarms interacts with the generator control.
- The condition that generates the alarm can be, for instance, the overcoming of a threshold. In this case, the source will be one of the limit thresholds LIMx.
- If instead, the alarm must be displayed depending on the status of an external digital input, then the source will be an INPx.
- With the same criteria, it is possible to also link complex conditions to an alarm, resulting from the logic combination of inputs, limits, etc. In this case, the Boolean logic variables PLCx must be used.
- For every alarm, the user can define a free message that will appear on the alarm page.
- The properties of the user alarms can be defined in the same way as the normal alarms. You can choose whether a certain alarm will stop the engine, activate the siren, close the global alarm output, etc. See chapter *Alarm properties*.
- When several alarms are active at the same time, they are displayed sequentially, and their total number is shown on the status bar.
- To reset one alarm that has been programmed with latch, use the dedicated command in the commands menu.
- For details on alarm programming and definition, refer to setup menu M32.

PLC Logic (PLCx)

- You can set a *ladder* program with the *Customisation manager* software for the RGK PLC logic, to easily create any function required for the genset accessory applications.
- You can enter all the variables managed by the RGK800 in the program logic, such as inputs (INPx), limit thresholds (LIMx), remote variables (REMX), and controller states (RALx), etc.
- The results of processing the various branches of the ladder logic are saved in internal variables (PLCx) which can then be used to control the outputs of the RGK800, or as backup memories to build a more complex logic, or also to control user-defined alarms (UAx).
- The logic function created with the ladder program can be verified in real

comandare degli allarmi definiti dall'utente (UAX).

- Il funzionamento della logica creata con il programma ladder può essere verificato in tempo reale ed eventualmente corretto tramite l'apposita finestra del software *Customization manager*.

Test Automatico

- Il test automatico e' una prova periodica che viene eseguita a scadenze fisse (intervallo impostabile in sede di setup) se il sistema si trova in modo AUT e se la funzione è stata abilitata.
- E' possibile decidere in quali giorni della settimana può essere eseguito il test ed in quale momento della giornata (ore-minuti).
- Vedere il menu *M16 Test Automatico* per maggiori dettagli sulla programmazione.
- Dopo l'avviamento il gen-set funziona per un tempo impostabile esaurito il quale si arresta. Prima dell'avviamento si ha la visualizzazione sul display della scritta 'T.AUT'.
- Tramite specifica impostazione di setup, e' possibile fare in modo che il test automatico venga eseguito anche se e' presente il segnale di stop esterno.



- L'abilitazione / disabilitazione del test automatico può essere effettuata anche senza entrare nel menu Setup nel seguente modo:
 - Spostarsi sulla pagina 'TEST AUTOMATICO e premere i tasti ◀ e START se si vuole abilitare la funzione oppure ◀ e STOP se la si vuole disabilitare.
- Il test automatico può essere interrotto premendo il tasto OFF.

CAN bus

- La porta CAN consente di connettere RGK800 alle centraline elettroniche di controllo (ECU) dei moderni motori, allo scopo di:
- Leggere le misure contenute nella ECU senza aggiungere sensori sul motore
- Semplificare notevolmente il cablaggio
- Ottenere una diagnostica completa e dettagliata
- Evitare il montaggio di schede di decodifica tipo CIU o Coo (coordinator)
- Controllare direttamente da CAN l'avviamento e l'arresto dei motori (quando supportato dalla ECU)
- La scheda funziona in abbinamento alle ECU dei motori piu' diffusi nelle applicazioni per gruppi elettrogeni, utilizzando lo standard definito dalla SAE J1939.
- Per la programmazione dei parametri relativi al CAN fare riferimento al menu *M21 CANBUS*

Misure supportate

- La porta CAN è in grado di decodificare e rendere disponibili una serie di misure definite dallo standard J1939 ed indicate da un numero (SPN, Suspect Parameter Number).
- A seconda del tipo di motore, sono disponibili un certo numero di misure (un sottoinsieme delle misure possibili) che vengono visualizzate sul display dell' RGK800.
- Le misure sono raggruppate in diverse sotto-pagine, che possono essere visualizzate premendo i tasti ◀ e ▶ .



time and if necessary corrected in the relevant window of the *Customisation manager*.

Automatic test

- The automatic test is a periodic test carried out at set intervals (set during setup) if the system is in AUT mode and the function has been enabled.
- It is possible to decide in which days of the week the automatic test can be executed and at what time of the day (hours:minutes).
- See menu *M16 Automatic test* for more details on automatic test programming.
- After starting, the genset runs for a set time, after which it will stop. The message 'T.AUT' is displayed before the generator starts.
- The automatic test can be set to run in setup also if there is an external stop signal.

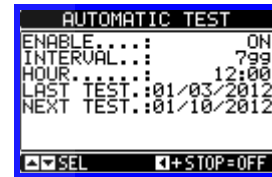

- The automatic test can be enabled/disabled without opening the Setup menu in the following way:
 - Open the 'AUTOMATIC TEST' page and press the keys ◀ and START to enable the function, or the keys ◀ and STOP to disable it.
- The automatic test can be stopped with the OFF key.

CAN bus

- The CAN port allows RGK800 controllers to be connected to the electronic control units (ECU) of modern engines in order to:
- Read the measurements contained in the ECU without adding sensors to the engine
- Considerably simplify wiring
- Obtain complete, detailed diagnostics
- Avoid assembly of CIU or Coo (coordinator) type decoding boards
- Permit direct control from CAN of engine stopping and starting (where permitted)
- The board functions in combination with the ECUs of the engines most widely used in gensets applications, using the standard defined by the SAE J1939.
- For details on CAN parameters, see setup menu *M21 CANBUS*.

Supported measurements

- The CAN port is able to decode and make available a set of measurements defined by the J1939 standard and identified by a number (SPN, Suspect Parameter Number).
- According to the type of engine, a certain number of measurements are available (a sub-set of possible measurements) that are shown on the display of the RGK800.
- The measures are grouped in several sub-pages, that can be viewed pressing ◀ and ▶ keys.

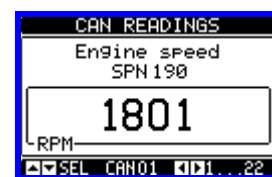

- Nella pagina successiva vengono visualizzati gli eventuali messaggi di diagnostica.
- I giri motore, la pressione dell'olio e la temperatura del liquido di raffreddamento vengono prelevate direttamente dal CAN, quindi non è necessario né il cablaggio né l'impostazione dei relativi sensori.

SPN	Descrizione	UDM
190	Giri motore	RPM
100	Pressione olio	Bar
110	Temperatura liquido raff.	°C
247	Ore motore ECU	h
102	Pressione turbo	Bar
105	Temperatura aspirazione	°C
183	Consumo istantaneo	l/h
513	Coppia attuale	%
512	Coppia richiesta	%
91	Posizione pedale acceleratore	%
92	Percentuale di carico	%
-	Lampada protezione	On-Off
-	Lampada gialla preallarme	On-Off
-	Lampada rossa allarme	On-Off
-	Lampada malfunzionamento	On-Off
174	Temperatura carburante	°C
175	Temperatura olio	°C
94	Pressione carburante	Bar
98	Livello olio	%
101	Pressione carter	Bar
109	Pressione liquido raffreddamento	Bar
111	Livello liquido raffreddamento	%
97	Acqua nel carburante	On-Off
158	Tensione batteria	VDC
106	Press. aspirazione	Bar
108	Press. atmosferica	Bar
173	Temperatura gas di scarico	°C

- Quando la ECU è spenta le misure non sono disponibili e vengono quindi sostituite da dei trattini.
- Se una misura non è disponibile su un particolare motore, viene visualizzata la scritta NA (not available).
- Se infine la misura è in errore (per esempio il sensore è scollegato) al suo posto viene visualizzato ERR.

Diagnostica

- In caso di anomalie, molte delle ECU segnalano il problema con un codice standard J1939, detto DTC (Diagnostic Trouble Code) costituito da SPN+FMI, dove SPN (Suspect Parameter Number) identifica il segnale interessato dall'anomalia, mentre FMI (Failure Mode Indicator) identifica il tipo di anomalia.

Ad esempio:

SPN-FMI
100-01

indica SPN 100 (pressione olio) e FMI 01 (troppo bassa).

- Data l'elevato numero di sensori collegati ad una ECU, vengono gestiti un numero elevato di possibili codici. In presenza di una anomalia, essa viene indicata sul display dell' RGK800 sia con la sigla che con la descrizione in lingua, nella pagina *Diagnostica CAN*.
- In caso di più allarmi presenti contemporaneamente essi vengono fatti ruotare.
- A seconda della gravità del codice viene di solito generato anche un allarme di lampada gialla (preallarme) o lampada rossa (allarme).
- Alcune ECU non adottano lo standard J1939 per la codifica degli allarmi. Anche in questo caso i DTC vengono visualizzati con il loro codice numerico e, quando possibile, con una descrizione in chiaro.
- Per azzerare gli allarmi premere o **OFF**, come di consueto.
- Se abilitato, l' RGK800 invierà sul CANbus un comando di reset allarmi appropriato al tipo di ECU selezionata.



- The next page shows the diagnostic messages.
- Engine speed, oil pressure and cooling fluid temperature are taken directly from the CAN; therefore, neither wiring or setting of the related sensors is required.

SPN	Description	U/M
190	Engine speed	RPM
100	Oil pressure	Bar
110	Coolant temperature	°C
247	ECU engine hours	h
102	Boost pressure	Bar
105	Intake manifold temperature	°C
183	Fuel rate	l/h
513	Actual torque	%
512	Demand torque	%
91	Accelerator pedal position	%
92	Load percentage	%
-	Protection indicator	On-Off
-	Amber warning indicator	On-Off
-	Red alarm indicator	On-Off
-	Malfunction indicator	On-Off
174	Fuel temperature	°C
175	Oil temperature	°C
94	Fuel delivery pressure	Bar
98	Oil level	%
101	Crankcase pressure	Bar
109	Coolant pressure	Bar
111	Coolant level	%
97	Water in fuel	On-Off
158	Battery voltage	VDC
106	Air intake pressure	Bar
108	Barometric pressure	Bar
173	Exhaust gas temperature	°C

- When the ECU is off, the measurements are not available and are therefore replaced by hyphens.
- If a measurement is not available on a particular engine, NA (Not Available) is displayed.
- If a measurement is incorrect (for example, the sensor is disconnected) ERR is displayed instead of this.

Diagnostics

- In the case of failures, many ECUs highlight the problem with a J1939 standard code, called DTC (Diagnostic Trouble Code) consisting of SPN+FMI, where SPN (Suspect Parameter Number) identifies the signal affected by the fault, while FMI (Failure Mode Indicator) identifies the type of failure.

For example:

SPN-FMI
100-01

indicates SPN 100 (oil pressure) and FMI 01 (too low).

- In view of the many sensors connected to an ECU, a high number of possible codes is managed. In the case of a fault, this is indicated on the display of the RGK800 with both a code and with a description in the related language, in the last of the sub-pages dedicated to the CAN.
- In the case of several simultaneous alarms, these are cycled periodically.
- According to the seriousness of the code, an amber alarm indicator (warning) or red alarm indicator (critical alarm) is usually generated.
- Some ECUs do not use the J1939 standard to code the alarms. Also in this case, the DTCs are displayed with their numeric code and, when possible, with an uncoded description.
- To reset the alarms, press or **OFF**, as usual.
- If enabled, the RGK800 will send a reset alarm command, according to the type of ECU selected, on the BUS.

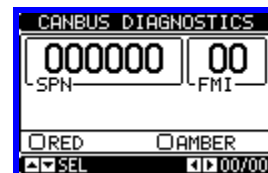

Porta di programmazione IR

- La configurazione dei parametri dell'RGK800 si può effettuare tramite la porta ottica frontale, attraverso la chiavetta di programmazione IR-USB CX01 oppure la chiavetta IR-WiFi CX02.
- Questa porta di programmazione ha i seguenti vantaggi:
 - Consente di effettuare la configurazione e la manutenzione dell'RGK800 senza la necessità di accedere al retro dell'apparecchio e quindi di aprire il quadro elettrico.
 - E' galvanicamente isolata dalla circuiteria interna dell'RGK800, garantendo la massima sicurezza per l'operatore.
 - Consente una elevata velocità di trasferimento dei dati.
 - Consente una protezione frontale IP65.
 - Restringe la possibilità di accessi non autorizzati alla configurazione del dispositivo.
- Semplicemente avvicinando una chiavetta CX.. alla porta frontale ed inserendo le spine negli appositi fori, si otterrà il vicendevole riconoscimento dei dispositivi evidenziato dal colore verde del LED LINK sulla chiavetta di programmazione.



Impostazione parametri da PC

- Mediante il software di set-up *Customization manager* è possibile effettuare il trasferimento dei parametri di set-up (precedentemente impostati) da RGK800 al disco del PC e viceversa.
- Il trasferimento dei parametri da PC a RGK può essere parziale, cioè solo i parametri dei menù specificati.
- Oltre ai parametri con il PC è possibile definire:
 - Dati relativi alle caratteristiche delle curve dei sensori di pressione, temperatura, livello carburante e della protezione termica del generatore.
 - Logo personalizzato che appare alla messa in tensione ed ogniqualvolta si esce dal set-up da tastiera.
 - Pagina informativa dove poter inserire informazioni, caratteristiche, dati ecc. concernenti l'applicazione.
 - Programmazione e debug della logica PLC
 - Caricamento di set di lingue alternative a quelle di default.

IR programming port

- The parameters of the RGK800 can be configured through the front optical port, using the IR-USB CX01 programming dongle, or with the IR-WiFi CX02 dongle.
- This programming port has the following advantages:
 - You can configure and service the RGK800 without access to the rear of the device or having to open the electrical board.
 - It is galvanically isolated from the internal circuits of the RGK800, guaranteeing the greatest safety for the operator.
 - High speed data transfer.
 - Ip65 front panel.
 - Limits the possibility of unauthorized access with device config.
- Simply hold the CX.. dongle up to the front panel, connecting the plugs to the relevant connectors, and the device will be acknowledged as shown by the LINK LED on the programming dongle flashing green.



Parameter setting (setup) with PC

- You can use the *Customization manager* set-up software to transfer (previously programmed) set-up parameters from the RGK800 to the hard drive of the PC and vice versa.
- The parameter may be partially transferred from the PC to the RGK, transferring only the parameters of the specified menus.
- The PC can be used to set parameters and also the following:
 - Data on the characteristics of the pressure, temperature, fuel level sensor curves, and the generator protection
 - Customised logo displayed on power-up and every time you exit keyboard setup.
 - Info page where you can enter application information, characteristics, data, etc.
 - PLC logic debug and programming.
 - Load alternative set of languages to default.

Impostazione dei parametri (setup) dal pannello frontale

- Per accedere al menu di programmazione dei parametri (setup):
 - predisporre la scheda in modalità **OFF**
 - dalla normale visualizzazione misure, premere ✓ per richiamare il menu principale
 - selezionare l'icona . Se essa non è abilitata (visualizzata in grigio) significa che è necessario inserire la password di sblocco (vedere capitolo *Accesso tramite password*).
 - premere ✓ per accedere al menu impostazioni.
- Viene visualizzata la tabella in figura, con la selezione dei sotto-menu di impostazione, nei quali sono raggruppati tutti i parametri secondo un criterio legato alla loro funzione.
- Selezionare il menu desiderato tramite i tasti ▲ ▼ e confermare con ✓.
- Per uscire e tornare alla visualizzazione misure premere **OFF**.



Impostazione: selezione menu

- Nella seguente tabella sono elencati i sottomenu disponibili :

Cod	MENU	DESCRIZIONE
M01	UTILITA'	Lingua, luminosità, pagine display ecc.
M02	GENERALE	Dati caratteristici dell'impianto
M03	PASSWORD	Impostazione codici di accesso
M04	CONFIGURAZIONI	Configurazioni multiple 1..4 selezionabili
M05	BATTERIA	Parametri batteria gruppo
M06	ALLARMI ACUSTICI	Controllo buzzer interno e sirena
M07	VELOCITA' MOTORE	Sorgente misura RPM, soglie limite
M08	PRESSIONE OLIO	Sorgente misura, soglie limite
M09	TEMPERATURA LIQ.	Sorgente misura, soglie limite
M10	LIVELLO CARB.	Sorgente misura, soglie limite, rabbocco
M11	AVVIAMENTO	Modo avviamento e arresto motore
M12	COMMUTAZIONE	Modo commutazione carico
M13	CONTROLLO RETE	Limiti di accettabilità tensione rete
M14	CONTROLLO GEN.	Limiti di accettabilità tensione
M15	PROT. GENERATORE	Soglie, curve termiche, guasto a terra
M16	TEST AUTOMATICO	Periodo, durata, modo test automatico
M17	MANUTENZIONE	Intervalli di manutenzione
M18	INGRESSI PROG.	Funzioni ingressi digitali programmabili
M19	USCITE PROG.	Funzioni uscite digitali programmabili
M20	COMUNICAZIONE	Indirizzo, formato, protocollo
M21	CAN BUS	Tipo ECU, opzioni di controllo
M22	GESTIONE CARICO	Gestione carico fittizio, carichi prioritari
M23	VARIE	Funzioni quali mutual stand-by, EJP
M24	SOGLIE LIMITE	Soglie limite programmabili su misure
M25	CONTATORI	Contatori generici programmabili
M26	PAGINE UTENTE	Pagine con misure a scelta
M27	REMOTAZIONE	Segnalazione allarmi/stati su relè esterni
M28	INGRESSO RESISTIVO	Ingresso resistivo ausil. programmabile
M29	INGRESSI ANALOGICI	Ingressi in
M30	USCITE ANALOGICHE	Uscite analogiche tensione/corrente
M31	IMPULSI ENERGIA	Impulsi di conteggio energia
M32	ALLARMI UTENTE	Allarmi programmabili
M33	PROPRIETA' ALLARMI	Abilitazione ed effetto degli allarmi

- Selezionare il sotto-menu e premere il tasto ✓ per visualizzare i parametri.
- Tutti i parametri sono visualizzati con codice, descrizione, valore attuale.

Parameter setting (setup) from front panel

- To open the parameters programming menu (setup):
 - turn the unit in **OFF** mode
 - in normal measurements view, press ✓ to call up the main menu
 - select the icon . If it is disabled (displayed in grey) you must enter the password (see chapter *Password access*).
 - press ✓ to open the setup menu.
- The table shown in the illustration is displayed, with the settings sub-menus of all the parameters on the basis of their function.
- Select the required menu with keys ▲ ▼ and confirm with ✓.
- Press **OFF** to return to the valves view.



Settings: menu selection

- The following table lists the available submenus:

Cod	MENU	DESCRIPTION
M01	UTILITY	Language, brightness, display pages, etc.
M02	GENERAL	System specifications
M03	PASSWORD	Password settings
M04	CONFIGURATIONS	1..4 multiple configurations selectable
M05	BATTERY	Genset battery parameters
M06	ACOUSTIC ALARMS	Internal buzzer and external siren control
M07	ENGINE SPEED	Limit thresholds, rpm valve source
M08	OIL PRESSURE	Limit thresholds, valve source
M09	COOLANT TEMP.	Limit thresholds, valve source
M10	FUEL LEVEL	Filling, limit thresholds, measurement
M11	ENGINE STARTING	Engine start/stop mode
M12	LOAD SWITCHING	Load switching mode
M13	MAINS CONTROL	Mains voltage limits of acceptability
M14	GEN CONTROL	Generator voltage limits of acceptability
M15	GEN PROTECTION	Ground-fault, protection curves,
M16	AUTOMATIC TEST	Automatic test mode, duration, period
M17	MAINTENANCE	Maintenance intervals
M18	PROG. INPUTS	Programmable digital inputs functions
M19	PROG. OUTPUTS	Programmable digital outputs functions
M20	COMMUNICATION	Address, format, protocol
M21	CAN BUS	ECU type, control options
M22	LOAD MANAGEMENT	Priority loads, dummy load management
M23	MISCELLANEOUS	Mutual stand-by, EJP, function, etc.
M24	LIMIT THRESHOLDS	Customisable limit thresholds
M25	COUNTERS	Programmable generic counters
M26	USER PAGES	Custom page dimensions
M27	REMOTE ALARMS	External relay alarm/state signals
M28	RESISTIVE INPUT	Programmable aux. resistive input
M29	ANALOG INPUTS	Voltage/current/temperature inputs
M30	ANALOG OUTPUTS	Voltage/current outputs
M31	ENERGY PULSES	Energy metering pulses
M32	USER ALARM	Programmable alarms
M33	ALARM PROPERTIES	Alarms effect enabling

- Select the sub-menu and press ✓ to show the parameters.
- Each parameter is shown with code, description and actual setting value.

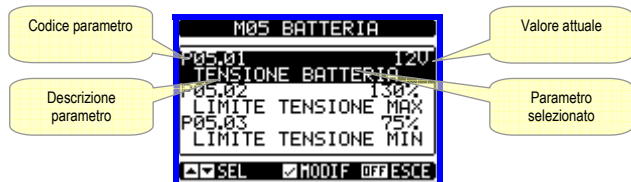

Impostazione: selezione parametri

- Se si vuole modificare il valore di un parametro, dopo averlo selezionato premere ✓.
- Se non è stata immessa la password livello Avanzato, non sarà possibile accedere alla pagina di modifica, e verrà visualizzato un messaggio di accesso negato.
- Se invece si ha l'accesso, verrà visualizzata la pagina di modifica.

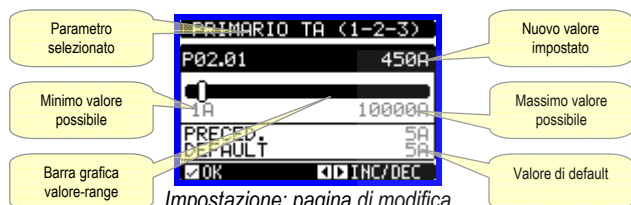

Impostazione: pagina di modifica

- Quando si è in modalità modifica, il valore può essere modificato con i tasti ◀ e ▶. Vengono visualizzati anche una barra grafica che indica il range di impostazione, i valori minimi e massimi possibili, il valore precedente e quello di default.
- Premendo ◀ + ▲ il valore viene impostato al minimo possibile, mentre con ▲ + ▶ viene impostato al massimo.
- Premendo contemporaneamente ◀ + ▶ l'impostazione viene riportata al valore di default di fabbrica.
- Durante l'impostazione di un testo, con i tasti ▲ e ▼ si seleziona il carattere alfanumerico e con ◀ e ▶ si sposta il cursore all'interno del testo. Premendo contemporaneamente ▲ e ▼ la selezione alfanumerica si posiziona direttamente sul carattere 'A'.
- Premere ✓ per tornare alla selezione parametri. Il valore immesso rimane memorizzato.
- Premere OFF per salvare i cambiamenti ed uscire dall'impostazione. Il controller esegue un reset e ritorna in funzionamento normale.
- Se non vengono premuti tasti per 2 minuti consecutivi, il menu setup viene abbandonato automaticamente e il sistema torna alla visualizzazione normale senza salvare i parametri.
- Rammentiamo che, per i soli dati di set-up modificabili da tastiera, è possibile fare una copia di sicurezza nella memoria eeprom dell'RGK800. Questi stessi dati all'occorrenza possono essere ripristinati nella memoria di lavoro I comandi di copia di sicurezza e ripristino dei dati sono disponibili nel menù comandi.

Tabella parametri

M01 - UTILITA'	UdM	Default	Range
P01.01 Lingua		English	English Italiano Francais Espagnol Portuguese
P01.02 Impostazione orologio alla alimentazione		OFF	OFF-ON
P01.03 Modalità operativa alla alimentazione		Modo OFF	Modo OFF Precedente
P01.04 Contrasto LCD	%	50	0-100
P01.05 Intensità retroilluminazione display alta	%	100	0-100
P01.06 Intensità retroilluminazione display bassa	%	25	0-50
P01.07 Tempo passaggio a retroilluminazione bassa	s	180	5-600
P01.08 Ritorno a pagina di default	s	300	OFF / 10-600
P01.09 Pagina di default		VLL	(lista pagine)
P01.10 Identificativo generatore		(vuoto)	Stringa 20 car.

- P01.01 - Selezione lingua per i testi sul display.
- P01.02 - Attivazione accesso automatico al setup dell'orologio dopo una messa in tensione.
- P01.03 - Alla messa in tensione, l'apparecchio parte in modalità OFF oppure nella stessa modalità in cui era stato spento.
- P01.04 - Regolazione del contrasto del LCD.
- P01.05 - Regolazione della retroilluminazione alta del display.
- P01.06 - Regolazione della retroilluminazione bassa del display.
- P01.07 - Ritardo passaggio a retroilluminazione bassa del display.
- P01.08 - Ritardo di ripristino della visualizzazione della pagina di default quando non vengono premuti tasti. Se impostato a OFF il display rimane sempre sulla ultima pagina selezionata manualmente.
- P01.09 - Pagina di default visualizzata dal display alla accensione e dopo il ritardo.
- P01.10 - Testo libero con nome alfanumerico identificativo dello specifico generatore. Usata



Set-up: parameter selection

- To modify the setting of one parameter, select it and then press ✓.
- If the Advanced level access code has not been entered, it will not be possible to enter editing page and an access denied message will be shown.
- If instead the access rights are confirmed, then the editing screen will be shown.

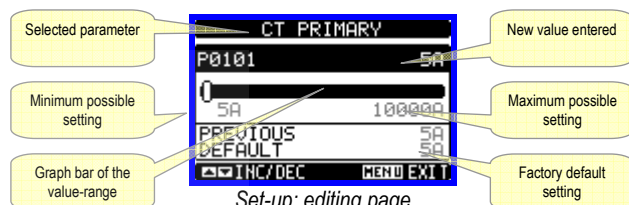

Set-up: editing page

- When the editing screen is displayed, the parameter setting can be modified with ◀ and ▶ keys. The screen shows the new setting, a graphic bar that shows the setting range, the maximum and minimum values, the previous setting and the factory default.
- Pressing ◀ + ▲ the value is set to the minimum possible, while with ▲ + ▶ it is set to the maximum.
- Pressing simultaneously ◀ + ▶, the setting is set to factory default.
- During the entry of a text string, keys ▲ and ▼ are used to select the alphanumeric character while ◀ and ▶ are used to move the cursor along the text string. Pressing keys ▲ and ▼ simultaneously will move the character selection straight to character 'A'.
- Press ✓ to go back to the parameter selection. The entered value is stored.
- Press OFF to save all the settings and to quit the setup menu. The controller executes a reset and returns to normal operation.
- If the user does not press any key for more than 2 minutes, the system leaves the setup automatically and goes back to normal viewing without saving the changes done on parameters.
- N.B.: a backup copy of the setup data (settings that can be modified using the keyboard) can be saved in the eeprom memory of the RGK800. This data can be restored when necessary in the work memory. The data backup 'copy' and 'restore' commands can be found in the commands menu.

Table of parameters

M01 - UTILITY	UdM	Default	Range
P01.01 Language		English	English Italiano Francais Espagnol Portuguese
P01.02 Set power delivery clock		OFF	OFF-ON
P01.03 Power-on operating mode		OFF mode	OFF mode Previous
P01.04 LCD contrast	%	50	0-100
P01.05 Display backlight intensity high	%	100	0-100
P01.06 Display backlight intensity low	%	25	0-50
P01.07 Time to switch to low backlighting	s	180	5-600
P01.08 Return to default page	s	300	OFF / 10-600
P01.09 Default page		VLL	(page list)
P01.10 Generator identifier		(empty)	String 20 chr.

- P01.01 - Select display text language.
- P01.02 - Active automatic clock settings access after power-up.
- P01.03 - Start system in OFF mode after power-up or in same mode it was switched off in.
- P01.04 - Adjust LCD contrast.
- P01.05 - Display backlight high adjustment.
- P01.06 - Display backlight low adjustment.
- P01.07 - Display backlight low delay.
- P01.08 - Default page display restore delay when no key pressed. If set to OFF the display will always show the last page selected manually.
- P01.09 - Default page displayed on power-up and after delay.
- P01.10 - Free text with alphanumeric identifier name of specific generator. Used also for identification after remote reporting alarms/events via SMS/E-mail.

anche per identificarsi dopo telesegnalazione di allarmi/eventi via SMS / E.mail.

M02 - GENERALE		UdM	Default	Range
P02.01	Primario TA Nr. 1-2-3	A	5	1-10000
P02.02	Secondario TA Nr. 1-2-3	A	5	1-5
P02.03	Lettura corrente TA Nr. 1-2-3		Carico	Carico Generatore
P02.04	Primario TA Nr. 4	A	5	1-10000
P02.05	Secondario TA Nr.4	A	5	1-5
P02.06	Lettura corrente TA Nr. 4		OFF	OFF Neutro Terra
P02.07	Utilizzo TV		OFF	OFF-ON
P02.08	Primario TV	V	100	50-50000
P02.09	Secondario TV	V	100	50-500
P02.10	Controllo sequenza fasi		OFF	OFF L1-L2-L3 L3-L2-L1

P02.01 - Valore del primario dei trasformatori di corrente delle fasi. Esempio: con TA 800/5 impostare 800.
P02.02 - Valore del secondario dei trasformatori di corrente delle fasi. Esempio: con TA 800/5 impostare 5.
P02.03 - Posizionamento dei TA delle fasi. Se posizionati sul carico, la corrente (e relative potenza ed energia) vengono attribuite alla rete o al generatore a seconda di quale interruttore è chiuso.
P02.04 - Valore del primario del quarto trasformatore di corrente.
P02.05 - Valore del secondario del quarto trasformatore di corrente.
P02.06 - Posizionamento del quarto TA. **OFF** = non montato. **Neutro** = Lettura corrente di neutro. **Terra** = Lettura corrente dispersione a terra. In quest'ultimo caso è possibile impostare delle soglie di intervento sul guasto a terra.
P02.07 - Utilizzo trasformatori di tensione (TV) sugli ingressi di misura tensione rete / generatore.
P02.08 - Valore del primario degli eventuali trasformatori di tensione.
P02.09 - Valore del secondario degli eventuali trasformatori di tensione.
P02.10 - Abilitazione controllo sequenza fasi. **OFF** = nessun controllo. **Diretta** = L1-L2-L3. **Inversa** = L3-L2-L1. Nota: Abilitare anche i corrispondenti allarmi.

M03 - PASSWORD		UdM	Default	Range
P03.01	Utilizzo password		OFF	OFF-ON
P03.02	Password livello Utente		1000	0-9999
P03.03	Password livello Avanzato		2000	0-9999
P03.04	Password accesso remoto		OFF	OFF/1-9999

P03.01 - Se impostato ad OFF, la gestione delle password è disabilitata e l'accesso alle impostazioni e al menu comandi è libero.
P03.02 - Con P03.01 attivo, valore da specificare per attivare l'accesso a livello utente. Vedere capitolo Accesso tramite password.
P03.03 - Come P03.02, riferito all'accesso livello Avanzato.
P03.04 - Se impostato ad un valore numerico, diventa il codice da specificare via comunicazione seriale prima di poter inviare comandi da controllo remoto.

M04 - CONFIGURAZIONI (CNFn, n=1...4)		UdM	Default	Range
P04.n.01	Tensione nominale	V	400	50-500000
P04.n.02	Tipo di collegamento		L1-L2-L3-N	L1-L2-L3-N L1-L2-L3 L1-N-L2 L1-N
P04.n.03	Tipo controllo tensioni		L-L	L-L L-N L-L + L-N
P04.n.04	Corrente nominale	A	5	1-10000
P04.n.05	Frequenza nominale	Hz	50	50 60 400
P04.n.06	Giri nominali motore	RPM	1500	750-3600
P04.n.07	Potenza attiva nominale	kW	Aut	Aut / 1-10000
P04.n.08	Potenza apparente nominale	kVA	Aut	Aut / 1-10000

Nota: Questo menu è diviso in 4 sezioni, riferite alle 4 configurazioni CNF1...CNF4. Vedere apposito capitolo sulla gestione configurazioni variabili.
P04.n.01 - Tensione nominale della rete e del generatore. Per sistemi polifase, impostare sempre la tensione concatenata.
P04.n.02 - Scelta del tipo di connessione, trifase con/senza neutro, bifase o monofase.
P04.n.03 - Controlli di tensione effettuati su concatenate, tensioni di fase o entrambe.
P04.n.04 - Corrente nominale del generatore. Usata per l'impostazione percentuale delle soglie di protezione.
P04.n.05 - Frequenza nominale della rete e del generatore.
P04.n.06 - Numero di giri nominali del motore (RPM).
P04.n.07 - Potenza attiva nominale del generatore. Usata per l'impostazione percentuale delle soglie di protezione, gestione carico fittizio, carichi prioritari, ecc. Se impostato a Aut, viene calcolata usando tensione nominale e primario TA.
P04.n.08 - Potenza apparente nominale del generatore.

M05 - BATTERIA		UdM	Default	Range
P05.01	Tensione nominale batteria	V	12	12 / 24
P05.02	Limite tensione MAX	%	130	110-140%
P05.03	Limite tensione MIN	%	75	60-130%
P05.04	Ritardo tensione MIN/MAX	s	10	0-120

M02 - MAIN MENU		UdM	Default	Range
P02.01	Nos. 1-2-3 CT Primary	A	5	1-10000
P02.02	Nos. 1-2-3 CT Secondary	A	5	1-5
P02.03	Nos. 1-2-3 CT Current valve		Load	Load Generator
P02.04	No. 4 CT Primary	A	5	1-10000
P02.05	No. 4 CT Secondary	A	5	1-5
P02.06	No. 4 CT Current valve		OFF	OFF Neutral Earth
P02.07	VT Use		OFF	OFF-ON
P02.08	VT Primary	V	100	50-50000
P02.09	VT Secondary	V	100	50-500
P02.10	Phase sequence control		OFF	OFF L1-L2-L3 L3-L2-L1

P02.01 - Value of the phase current transformers primary. Example: set 800 for 800/5 CT.
P02.02 - Value of the phase current transformers secondary. Example: set 5 for 800/5 CT.
P02.03 - Positioning of phase CT. If positioned on load, the current (and the relative power and energy) are switched to the mains or generator on the basis of which circuit breaker is closed.
P02.04 - Primary value of the fourth current transformer.
P02.05 - Secondary value of the fourth current transformer..
P02.06 - Positioning of the fourth CT. **OFF** = not installed. **Neutral** = Neutral current reading. **Earth** = Earth leakage current reading. In this case ground fault thresholds of intervention can be set.
P02.07 - Using voltage transformers (TV) on mains/generator voltage metering inputs.
P02.08 - Primary value of any voltage transformer.S.
P02.09 - Secondary value of any voltage transformers.
P02.10 - Enable phase sequence control. **OFF** = no control. **Direct** = L1-L2-L3. **Reverse** = L3-L2-L1. Note: Enable also corresponding alarms.

M03 - PASSWORD		UdM	Default	Range
P03.01	Use password.		OFF	OFF-ON
P03.02	User level password		1000	0-9999
P03.03	Advanced level password		2000	0-9999
P03.04	Remote access password		OFF	OFF/1-9999

P03.01 - If set to OFF, password management is disabled and anyone has access to the settings and commands menu.
P03.02 - With P03.01 enabled, this is the value to specify for activating user level access. See Password access chapter.
P03.03 - As for P03.02, with reference to Advanced level access.
P03.04 - If set to a numeric value, this becomes the code to specify via serial communication before sending commands from a remote control.

M04 - CONFIGURATIONS (CNFn, n=1...4)		UdM	Default	Range
P04.n.01	Rated voltage	V	400	50-500000
P04.n.02	Type of connection		L1-L2-L3-N	L1-L2-L3-N L1-L2-L3 L1-N-L2 L1-N
P04.n.03	Type of voltage control		L-L	L-L L-N L-L + L-N
P04.n.04	Rated current	A	5	1-10000
P04.n.05	Rated frequency	Hz	50	50 60 400
P04.n.06	Rated engine rpm	RPM	1500	750-3600
P04.n.07	Rated active power	kW	Aut	Aut / 1-10000
P04.n.08	Rated apparent power	kVA	Aut	Aut / 1-10000

Note: This menu is divided into 4 sections, which refer to 4 configurations CNF1...CNF4. See relevant chapter on managing the variable configurations.
P04.n.01 - Rated voltage of mains and generator. Always set the line-to-line voltage for polyphase systems
P04.n.02 - Choice of the type of connection, 3-phase with/without neutral, 2-phase or single phase.
P04.n.03 - Voltage controls performed on line-to-line voltages, phase voltages or both.
P04.n.04 - Rated current of the generator. Used for the percentage settings of the protection thresholds.
P04.n.05 - Rated frequency of mains and generator.
P04.n.06 - Rated engine rpm.
P04.n.07 - Rated active power of the generator. Used for the percentage settings of the protection thresholds, dummy load management, priority loads, etc. If set to Aut, it is calculated using the CT primary and rated voltage.
P04.n.08 - Rated apparent power of the generator.

M05 - BATTERY		UdM	Default	Range
P05.01	Battery rated voltage	V	12	12 / 24
P05.02	MAX. voltage limit	%	130	110-140%
P05.03	MIN. voltage limit	%	75	60-130%
P05.04	MIN./MAX. voltage delay	s	10	0-120

P05.01 - Tensione nominale di batteria.
P05.02 - Soglia di intervento allarme tensione MAX batteria.
P05.03 - Soglia di intervento allarme tensione MIN batteria.
P05.04 - Ritardo di intervento allarmi MIN e MAX batteria.

P05.01 - Rated battery voltage.
P05.02 - Battery MAX. voltage alarm intervention threshold.
P05.03 - Battery MIN. voltage alarm intervention threshold.
P05.04 - Battery MIN. and MAX. alarms intervention delay.

M06 – ALLARMI ACUSTICI		UdM	Default	Range
P06.01	Modo suono sirena su allarme		A tempo	OFF Tastiera A tempo Ripetuto
P06.02	Tempo attivazione suono su allarme	s	30	OFF/1-600
P06.03	Tempo attivazione suono prima di avviamento	s	OFF	OFF / 1-60
P06.04	Tempo attivazione suono su inizio controllo remoto	s	OFF	OFF / 1-60
P06.05	Tempo attivazione suono su mancanza rete	s	OFF	OFF / 1-60
P06.06	Dispositivo segnalazione acustica		BUZZER+SI RENA	OFF SIRENA BUZZER BUZZER+SIR
P06.07	Buzzer su pressione tasti	s	0.15	OFF / 0.01-0.50

P06.01 - **OFF** = sirena disabilitata. **Tastiera** = Sirena suona continuamente fino a che non viene tacitata premendo un tasto sulla tastiera frontale. **A tempo** = Suona per il tempo specificato con P06.02. **Ripetuto** = Suona per il tempo P06.02, pausa per un tempo triplo, poi ripete ciclicamente.
P06.02 - Durata attivazione segnalazione acustica su allarme.
P06.03 - Durata attivazione segnalazione acustica prima di un qualsiasi avviamento motore.
P06.04 - Durata attivazione segnalazione acustica in seguito alla attivazione di un controllo remoto via canale di comunicazione.
P06.05 - Durata attivazione segnalazione acustica in seguito a mancanza tensione rete.
P06.06 - Scelta dispositivo di segnalazione acustica.
P06.07 - Attivazione e durata buzzer su pressione tasti.

M06 - ACOUSTIC ALARMS		UdM	Default	Range
P06.01	Siren mode for alarm.		Time	OFF Keyboard Time Repeat
P06.02	Siren activation time for alarm.	s	30	OFF/1-600
P06.03	Siren activation time before starting.	s	OFF	OFF / 1-60
P06.04	Siren activation time for emote control initialisation.	s	OFF	OFF / 1-60
P06.05	Siren activation time for mains outage.	s	OFF	OFF / 1-60
P06.06	Acoustic warning devices		BUZZER+SI REN	OFF SIREN BUZZER BUZZER+SIR
P06.07	Buzzer for key press	s	0.15	OFF / 0.01-0.50

P06.01 - **OFF** = siren disabled. **Keyboard** = Siren goes off continuously until silenced by pressing a key on the front panel. **Timed** = Activated for the specified time with P06.02. **Repeated** = Activated for time P06.02, pause for 3x time, then repeated periodically.
P06.02 - Duration of buzzer activation for alarm.
P06.03 - Duration of buzzer activation before engine start.
P06.04 - Duration of buzzer activation after remote control via communication channel.
P06.05 - Duration of buzzer activation after mains outage.
P06.06 - Select buzzer.
P06.07 - Activation and duration of buzzer for key press.

M07 – VELOCITA' MOTORE		UdM	Default	Range
P07.01	Sorgente misura velocità motore		W	OFF FREQ-GEN. W Pick-up LS Pick-up HS CAN
P07.02	Rapporto RPM / W - pick-up		1.000	0.001-50.000
P07.03	Limite velocità MAX	%	110	100-120
P07.04	Ritardo allarme velocità MAX	s	3.0	0.5-60.0
P07.05	Limite velocità MIN	%	90	80-100
P07.06	Ritardo allarme velocità MIN	s	5	0-600

P07.01 - Selezione sorgente dalla quale prelevare la misura dei giri motore. **OFF** = giri non visualizzati e controllati. **Freq. Gen** = RPM dedotti dalla frequenza dell'alternatore di potenza. A frequenza nominale corrispondono giri nominali. **W** = RPM misurati da frequenza del segnale W, con riferimento al rapporto RPM/W impostato con il parametro seguente. **Pick-up LS** = RPM misurati da sensore pick-up, usando ingresso a bassa sensibilità (per segnali robusti). **Pick-up HS** = come precedente, con ingresso a alta sensibilità (per segnali deboli). **CAN** = RPM letti dalla ECU motore tramite CAN bus.
P07.02 - Rapporto fra RPM e frequenza del segnale W o pick-up. Può essere impostato manualmente oppure acquisito automaticamente tramite la seguente procedura: Dalla pagina velocità motore, con motore in moto a giri nominali, premere contemporaneamente **START** e ✓ per 5 secondi. Il sistema acquisirà l'attuale velocità come quella nominale, usando la frequenza attuale del W per calcolare il valore del parametro P07.02.
P07.03 - **P07.04** - Soglia limite e ritardo per la generazione dell'allarme di velocità motore troppo alta.
P07.05 - **P07.06** - Soglia limite e ritardo per la generazione dell'allarme di velocità motore troppo bassa.

M07 - ENGINE SPEED		UdM	Default	Range
P07.01	Engine speed reading source		W	OFF FREQ-GEN. W Pick-up LS Pick-up HS CAN
P07.02	RPM/W ratio - pick-up		1.000	0.001-50.000
P07.03	MAX. speed limit	%	110	100-120
P07.04	MAX. speed alarm delay	s	3.0	0.5-60.0
P07.05	MIN. speed limit	%	90	80-100
P07.06	MIN. speed alarm delay	s	5	0-600

P07.01 - Select source for engine speed readings. **OFF** = rpm not displayed and controlled. **Freq. Gen** = RPM calculated on the basis of power alternator frequency. Rated rpm corresponds to rated frequency. **W** = RPM measured using the frequency of signal W, with reference to RPM/W ratio set with the following parameter. **Pick-up LS** = RPM measured by pick-up sensor, using a low sensitivity input (for strong signals). **Pick-up HS** = as above, with high-sensitivity input (for weak signals). **CAN** = RPM read by engine ECU through CAN bus.
P07.02 - Ratio between the RPM and the frequency of the W or pick-up signal. Can be set manually or acquired automatically through the following procedure: From the engine speed page, with engine running at nominal speed, press **START** and ✓ together for 5 seconds. The system will acquire the present speed as the rated one, using the present frequency of the W signal to calculate the value of parameter P07.02.
P07.03 - **P07.04** - Limit threshold and delay for generating engine speed too high alarm.
P07.05 - **P07.06** - Limit threshold and delay for generating engine speed too low alarm.

M08 – PRESSIONE OLIO		UdM	Default	Range
P08.01	Sorgente misura		OFF	OFF PRESS CAN AINx
P08.02	Nr. canale		1	1..8
P08.03	Tipo sensore resistivo		VDO	VDO VEGLIA DATCON CUSTOM ...
P08.04	Offset sensore resistivo	Ohm	0	-30.0 - +30.0
P08.05	Unità di misura pressione		bar	bar psi
P08.06	Preallarme pressione MIN	(bar/ psi)	3.0	0.1-180.0
P08.07	Limite allarme pressione MIN	(bar/ psi)	2.0	0.1-180.0

P08.01 - Specifica da quale sorgente viene prelevata la misura della pressione olio. **OFF** = non gestita. **PRESS** = prelevata dal sensore resistivo con ingresso analogico sul morsetto PRESS. **CAN** = Prelevata dal CAN bus. **AINx** = prelevata dall'ingresso analogico di un modulo di espansione EXP.

M08 - OIL PRESSURE		UdM	Default	Range
P08.01	Reading source		OFF	OFF PRESS CAN AINx
P08.02	Channel no.		1	1..8
P08.03	Type of resistive sensor		VDO	VDO VEGLIA DATCON CUSTOM ...
P08.04	Resistive sensor offset	Ohm	0	-30.0 - +30.0
P08.05	Pressure units of measurement		bar	bar psi
P08.06	MIN. pressure prealarm	(bar/ psi)	3.0	0.1-180.0
P08.07	MIN. pressure alarm limit	(bar/ psi)	2.0	0.1-180.0

P08.01 - Specifies which source is used for reading the oil pressure. **OFF** = not managed. **PRESS** = read from resistive sensor with analog input on PRESS terminal. **CAN** = Read from CAN bus. **AINx** = read from analog input of an EXP expansion module.
P08.02 - Channel number (x) to specify if AINx was selected for the previous parameter.

P08.02 - Numero di canale (x) da specificare se al parametro precedente è stato selezionato AINx.

P08.03 - Nel caso si utilizzi un sensore resistivo, seleziona quale curva utilizzare. Le curve possono essere impostate liberamente utilizzando il software Customization manager.

P08.04 - Nel caso si utilizzi un sensore resistivo, permette di aggiungere o togliere un offset in Ohm alla curva impostata, per compensare ad esempio la lunghezza dei cavi. Questo valore può essere anche impostato senza entrare in setup, tramite la funzione rapida nel menu comandi che consente di vedere le misure mentre si esegue la taratura.

P08.05 - Sceglie l'unità di misura per la pressione olio.

P08.06 - P08.07 - Definiscono rispettivamente le soglie di preallarme e di allarme per la pressione minima olio. Vedere rispettivi allarmi.

P08.03 - When using a resistive sensor, selects which curve to use. The curves can be custom set using the Customisation Manager software.

P08.04 - When using a resistive sensor, this lets you add or subtract an offset in Ohms from the set curve, to compensate for cable length for example. This value can also be set without opening setup by using the quick function in the commands menu which lets you view the measurements while calibrating.

P08.05 - Selects the unit of measurement for the oil pressure.

P08.06 - P08.07 - Define respectively the prealarm and alarm thresholds for MIN. oil pressure. See respective alarms.

M09 - TEMPERATURA LIQUIDO REFRIGERANTE		UdM	Defau.06It	Range
P09.01	Sorgente misura		OFF	OFF TEMP CAN AINx
P09.02	Nr. canale		1	1..8
P09.03	Tipo sensore resistivo		VDO	VDO VEGLIA DATCON CUSTOM
P09.04	Offset sensore resistivo	Ohm	0	-30.0 - +30.0
P09.05	Unità di misura temperatura		°C	°C °F
P09.06	Preallarme temperatura MAX	°	90	20-300
P09.07	Limite allarme temperatura MAX	°	100	20-300
P09.08	Limite allarme temperatura MIN	°	OFF	OFF/20-300
P09.09	Temperatura presa carico	°	OFF	OFF/20-300
P09.10	Soglia attivazione riscaldatore	°	OFF	OFF/20-300
P09.11	Soglia disattivazione riscaldatore	°	OFF	OFF/20-300
P09.12	Ritardo allarme sensore temperatura guasto	min	OFF	OFF / 1 - 60

P09.01 - Specifica da quale sorgente viene prelevata la misura della temperatura liquido refrigerante. **OFF** = non gestita. **TEMP** = Prelevata dal sensore resistivo con ingresso analogico sul morsetto TEMP. **CAN** = Prelevata dal CAN bus. **AINx** = prelevata dall'ingresso analogico di un modulo di espansione EXP.

P09.02 - Numero di canale (x) da specificare se al parametro precedente è stato selezionato AINx.

P09.03 - Nel caso si utilizzi un sensore resistivo, seleziona quale curva utilizzare. Le curve possono essere impostate liberamente utilizzando il software Customization manager.

P09.04 - Nel caso si utilizzi un sensore resistivo, permette di aggiungere o togliere un offset in Ohm alla curva impostata, per compensare ad esempio la lunghezza dei cavi. Questo valore può essere anche impostato senza entrare in setup, tramite la funzione rapida nel menu comandi che consente di vedere le misure mentre si esegue la taratura.

P09.05 - Sceglie l'unità di misura per la temperatura.

P09.06 - P09.07 - Definiscono rispettivamente le soglie di allarme e di preallarme per la temperatura massima liquido. Vedere rispettivi allarmi.

P09.08 - Definisce la soglia di allarme per la temperatura minima liquido. Vedere rispettivi allarmi.

P09.09 - Se la temperatura del motore è superiore a questa soglia (motore già caldo) , la presa del carico viene fatta dopo 5s invece che dopo il tempo normale di presenza impostato con P14.05. Se invece la temperatura è inferiore (motore freddo) viene atteso il tempo impostato.

P09.10 - P09.11 - Definiscono le soglie per il controllo on-off dell'uscita programmata con la funzione preriscaldamento.

P09.12 - Ritardo prima della generazione dell'allarme di sensore resistivo temperatura guasto.

M09 - COOLANT TEMPERATURE		UdM	Default	Range
P09.01	Reading source		OFF	OFF TEMP CAN AINx
P09.02	Channel no.		1	1..8
P09.03	Type of resistive sensor		VDO	VDO VEGLIA DATCON CUSTOM
P09.04	Resistive sensor offset	Ohm	0	-30.0 - +30.0
P09.05	Temperature unit of measurement		°C	°C °F
P09.06	MAX. temperature prealarm	°	90	20-300
P09.07	MAX. temperature alarm limit	°	100	20-300
P09.08	MIN. temperature alarm limit	°	OFF	OFF/20-300
P09.09	Load increase temperature	°	OFF	OFF/20-300
P09.10	Heater activation threshold	°	OFF	OFF/20-300
P09.11	Heater deactivation threshold	°	OFF	OFF/20-300
P09.12	Temperature sensor fault alarm delay	min	OFF	OFF / 1 - 60

P09.01 - Specifies which source is used for reading the coolant temperature. **OFF** = not managed. **TEMP** = Read from resistive sensor with analog input on TEMP terminal. **CAN** = Read from CAN bus. **AINx** = Read from analog input of an EXP expansion module.

P09.02 - Channel number (x) to specify if AINx was selected for the previous parameter.

P09.03 - When using a resistive sensor, selects which curve to use. The curves can be custom set using the Customisation manager software.

P09.04 - When using a resistive sensor, this lets you add or subtract an offset in Ohms from the set curve, to compensate for cable length for example. This value can also be set without opening setup by using the quick function in the commands menu which lets you view the measurements while calibrating.

P09.05 - Selects the unit of measurement for the temperature.

P09.06 - P09.07 - Define respectively the alarm and prealarm thresholds for MAX. temperature of the liquid. See respective alarms.

P09.08 - Defines the min. liquid temperature alarm threshold. See respective alarms.

P09.09 - If the engine temperature is higher than this threshold (engine is warm) , then the load is connected to the generator after 5s instead of waiting the usual presence delay set with P14.05. If instead the temperature is lower , then the system will wait the elapsing of the whole presence time.

P09.10 - P09.11 - Defines the thresholds for on-off control of the output programmed with the preheating function

P09.12 - Delay before a temperature resistive sensor fault alarm is generated.

M10 - LIVELLO CARBURANTE		UdM	Default	Range
P10.01	Sorgente misura		OFF	OFF FUEL CAN AINx
P10.02	Nr. canale		1	1..8
P10.03	Tipo sensore resistivo		VDO	VDO VEGLIA DATCON CUSTOM
P10.04	Offset sensore resistivo	Ohm	0	-30.0 - +30.0
P10.05	Unità di misura capacità		%	% gal
P10.06	Capacità serbatoio		OFF	OFF / 1-30000
P10.07	Preallarme carburante MIN	%	20	0-100
P10.08	Livello carburante MIN	%	10	0-100
P10.09	Livello start pompa rabbocco carburante	%	OFF	OFF/ 0-100
P10.10	Livello stop pompa rabbocco carburante	%	OFF	OFF/ 0-100
P10.11	Consumo orario nominale del motore	l/h	OFF	OFF / 0.0-100.0
P10.12	Sensibilità allarme furto carburante	%	OFF	OFF / 0-100
P10.13	Abilitazione pagina efficienza energetica		OFF	OFF ON

P10.01 - Specifica da quale sorgente viene prelevata la misura dell livello carburante. **OFF** =

M10 - FUEL LEVEL		UdM	Default	Range
P10.01	Reading source		OFF	OFF FUEL CAN AINx
P10.02	Channel no.		1	1..8
P10.03	Type of resistive sensor		VDO	VDO VEGLIA DATCON CUSTOM
P10.04	Resistive sensor offset	Ohm	0	-30.0 - +30.0
P10.05	Capacity unit of measurement		%	% gal
P10.06	Tank capacity		OFF	OFF / 1-30000
P10.07	MIN. fuel level prealarm	%	20	0-100
P10.08	MIN. fuel level	%	10	0-100
P10.09	Start filling with fuel pump level	%	OFF	OFF/ 0-100
P10.10	Stop filling with fuel pump level	%	OFF	OFF/ 0-100
P10.11	Rated hourly engine consumption	l/h	OFF	OFF / 0.0-100.0
P10.12	Fuel theft alarm sensitivity	%	OFF	OFF / 0-100
P10.13	Enable energy efficiency page		OFF	OFF ON

P10.01 - Specifies which source is used for reading the fuel level. **OFF** = not managed. **FUEL**

non gestita. **FUEL** = Prelevata dal sensore resistivo con ingresso analogico sul morsetto FUEL. **CAN** = Prelevata dal CAN bus. **AINx** = prelevata dall'ingresso analogico di un modulo di espansione EXP.

- P10.02** - Numero di canale (x) da specificare se al parametro precedente è stato selezionato AINx.
- P10.03** - Nel caso si utilizzi un sensore resistivo, seleziona quale curva utilizzare. Le curve possono essere impostate liberamente utilizzando il software Customization manager.
- P10.04** - Nel caso si utilizzi un sensore resistivo, permette di aggiungere o togliere un offset in Ohm alla curva impostata, per compensare ad esempio la lunghezza dei cavi. Questo valore può essere anche impostato senza entrare in setup, tramite la funzione rapida nel menu comandi che consente di vedere le misure mentre si esegue la taratura.
- P10.05** - Sceglie l'unità di misura per la capacità serbatoio e carburante residuo.
- P10.06** - Definisce la capacità del serbatoio, usata per l'indicazione della autonomia.
- P10.07 - P10.08** - Definiscono rispettivamente le soglie di preallarme e di allarme per il livello minimo carburante. Vedere rispettivi allarmi.
- P10.09** - Con livello carburante inferiore a questa soglia, avvia pompa rabbocco.
- P10.10** - Con livello carburante superiore o uguale a questa soglia, arresta pompa rabbocco.
- P10.11** - Consumo orario nominale del motore. Utilizzato per il calcolo della autonomia minima residua.
- P10.12** - Imposta un coefficiente per la sensibilità dell'allarme furto carburante. Valori bassi = alta sensibilità - Valori alti = bassa sensibilità. Valori suggeriti: fra 3% e 5%..
- P10.13** - Abilita la visualizzazione di una sotto-pagina della pagina livello carburante con i dati calcolati di efficienza energetica del gruppo elettrogeno.

= Read from resistive sensor with analog input on FUEL terminal. **CAN** = Read from CAN bus. **AINx** = Read from analog input of EXP expansion module.

- P10.02** - Channel number (x) to specify if AINx was selected for the previous parameter.
- P10.03** - When using a resistive sensor, selects which curve to use. The curves can be custom set using the Customisation manager software.
- P10.04** - When using a resistive sensor, this lets you add or subtract an offset in Ohms from the set curve, to compensate for cable length for example. This value can also be set without opening setup by using the quick function in the commands menu, which lets you view the measurements while calibrating.
- P10.05** - Selects the unit of measurement for fuel tank capacity and available fuel.
- P10.06** - Defines the fuel tank capacity, used to indicate autonomy.
- P10.07 - P10.08** - Defines respectively the prealarm and alarm thresholds for min. fuel level. See respective alarms.
- P10.09** - The fuel filling pump starts when the fuel drops below this level.
- P10.10** - The fuel filling pump stops when the fuel reaches or is higher than this level.
- P10.11** - Rated hourly engine consumption. Used to calculate minimum autonomy left.
- P10.12** - Sets a coefficient for fuel theft alarm sensitivity. Low values = high sensitivity - High values = low sensitivity. Suggested values between 3% and 5%.
- P10.13** - Enables the display of a sub-page on the fuel level page, with the genset energy efficiency data.

M11 - AVVIAMENTO MOTORE	UdM	Default	Range
P11.01 Soglia motore avviato da tensione alternatore caricabatteria	VDC	10.0	OFF/3.0-30
P11.02 Soglia motore avviato da tensione generatore	%	25	OFF/10-100
P11.03 Soglia motore avviato da frequenza generatore	%	30	OFF/10-100
P11.04 Soglia motore avviato da velocità motore	%	30	OFF/10-100
P11.05 Tempo preriscaldamento candele	s	OFF	OFF/1-600
P11.06 Temperatura stacco preriscaldamento carburante	°	OFF	OFF/20-300
P11.07 Timeout preriscaldamento carburante	s	OFF	OFF/1-900
P11.08 Tempo fra EV e start	s	1.0	OFF/1.0-30.0
P11.09 Numero tentativi di avviamento		5	1-30
P11.10 Durata tentativo di avviamento	s	5	1-60
P11.11 Pausa fra tentativi di avviamento	s	5	1-60
P11.12 Pausa avviamento interrotto e successivo	s	OFF	OFF/1-60
P11.13 Tempo inibizione allarmi dopo avviamento	s	8	1-120
P11.14 Tempo inibizione sovra velocità dopo avviamento	s	8	1-120
P11.15 Tempo di funzionamento decelerato	s	OFF	OFF/1-600
P11.16 Temperatura fine decelerazione	°	OFF	OFF/20-300
P11.17 Modo ciclo di raffreddamento		Carico	Sempre Carico Soglia temp.
P11.18 Tempo di raffreddamento	s	120	1-3600
P11.19 Soglia temperatura fine raffreddamento	°	OFF	OFF/1-250
P11.20 Tempo magneti di arresto	s	OFF	OFF/1-60
P11.21 Ritardo valvola gas	s	OFF	OFF/1-60
P11.22 Tempo cicchetto	s	OFF	OFF/1-60
P11.23 Tempo valvola aria	s	OFF	OFF/1-60
P11.24 Soglia stacco aria	%	5	1-100
P11.25 Nr. Tentativi avviamento con aria		2	1-10
P11.26 Modo tentativi aria		Consecutivi	Consecutivi Alternati
P11.27 Modo tentativi di avviamento aria compressa		OFF	OFF Consecutivi Alternati
P11.28 Modo elettrovalvola carburante		Normale	Normale Continuo
P11.29 Modo funzionamento candele		Normale	Normale +Start +Ciclo
P11.30 Modo funzionamento magneti di arresto		Normale	Normale Impulso No pausa

- P11.01** - Soglia riconoscimento motore in moto da tensione alternatore carica batteria (D+/AC).
- P11.02** - Soglia riconoscimento motore in moto da tensione del generatore (VAC).
- P11.03** - Soglia riconoscimento motore in moto tramite la frequenza del generatore.
- P11.04** - Soglia riconoscimento motore in moto tramite il segnale di velocità 'W' o pick-up.
- P11.05** - Tempo di preriscaldamento delle candele motore prima di avviamento.
- P11.06** - Temperatura motore sopra la quale viene interrotto il preriscaldamento carburante.
- P11.07** - Tempo massimo attivazione preriscaldamento carburante.
- P11.08** - Tempo che intercorre fra l'apertura della valvola carburante e l'attivazione del motorino di avviamento.
- P11.09** - Numero totale di tentativi di avviamento automatico del motore.
- P11.10** - Durata del tentativo di avviamento.
- P11.11** - Pausa tra un tentativo di avviamento durante il quale non è stato rilevato il segnale di motore in moto e quello successivo.
- P11.12** - Pausa tra un tentativo di avviamento interrotto causa falsa partenza motore ed il successivo tentativo di avviamento.
- P11.13** - Tempo di inibizione allarmi subito dopo avviamento motore. Utilizzato per gli allarmi con la proprietà motore in moto attivata. Esempio: minima pressione olio.
- P11.14** - Come parametro precedente, riferito in particolare agli allarmi di massima velocità.

M11 - ENGINE STARTING	UdM	Default	Range
P11.01 Battery charger alternator voltage engine start threshold	VDC	10.0	OFF/3.0-30
P11.02 Generator voltage engine start threshold	%	25	OFF/10-100
P11.03 Generator frequency engine start threshold	%	30	OFF/10-100
P11.04 Engine speed start threshold	%	30	OFF/10-100
P11.05 Glow plugs preheating time	s	OFF	OFF/1-600
P11.06 Fuel preheating disconnection temperature	°	OFF	OFF/20-300
P11.07 Fuel preheating timeout	s	OFF	OFF/1-900
P11.08 Time between Ev and start	s	1.0	OFF/1.0-30.0
P11.09 Number of attempted starts		5	1-30
P11.10 Duration of attempted starts	s	5	1-60
P11.11 Pause between attempted starts	s	5	1-60
P11.12 Pause between end of attempted start and next attempt	s	OFF	OFF/1-60
P11.13 Alarms inhibition time after starting	s	8	1-120
P11.14 Overspeed inhibition time after starting	s	8	1-120
P11.15 Deceleration time	s	OFF	OFF/1-600
P11.16 Deceleration end temperature	°	OFF	OFF/20-300
P11.17 Cooling cycle mode		Load	Always Load Temp. thresh.
P11.18 Cooling time	s	120	1-3600
P11.19 Cooling end temperature threshold	°	OFF	OFF/1-250
P11.20 Stop magnets time	s	OFF	OFF/1-60
P11.21 Gas valve delay	s	OFF	OFF/1-60
P11.22 Priming valve time	s	OFF	OFF/1-60
P11.23 Choke time	s	OFF	OFF/1-60
P11.24 Air disconnect threshold	%	5	1-100
P11.25 No. of attempted starts with air		2	1-10
P11.26 Air attempts mode		Consecutive	Consecutive Alternating
P11.27 Compressed air starting attempts mode		OFF	OFF Consecutive Alternating
P11.28 Fuel solenoid valve mode		Normal	Normal Continuous
P11.29 Glow plugs mode		Normal	Normal +Start +Cycle
P11.30 Stop magnets mode		Normal	Normal Pulse No pausa

- P11.01** - Battery charger alternator voltage engine running acknowledgement threshold (D+/AC).
- P11.02** - Generator voltage engine running acknowledgement threshold (VAC).
- P11.03** - Generator frequency engine running acknowledgement threshold.
- P11.04** - Engine running 'W' or pick-up speed signal acknowledgement threshold.
- P11.05** - Glow plug preheating time before starting.
- P11.06** - Engine temperature above which fuel preheating is disabled.
- P11.07** - Max. fuel preheating time.
- P11.08** - Time between the activation of fuel EV and the activation of starting motor.
- P11.09** - Total number of automatic engine start attempts.
- P11.10** - Duration of start attempt.
- P11.11** - Pause between one start attempt, during which no engine running signal was detected, and next attempt.
- P11.12** - Pause between one start attempt which was stopped due to a false start and next start attempt.
- P11.13** - Alarms inhibition time immediately after engine start. Used for alarms with the "engine running" property activated. Example: min. oil pressure
- P11.14** - As for previous parameter, with reference in particular to max. speed alarms.
- P11.15** - Programmed output energizing time with decelerator function.

P11.15 - Tempo di eccitazione della uscita programmato con la funzione *deceleratore*.
P11.16 - Temperatura motore sopra alla quale viene disabilitato il funzionamento decelerato.
P11.17 - Modo esecuzione ciclo di raffreddamento. **Sempre** = Il ciclo di raffreddamento viene eseguito sempre ad ogni spegnimento automatico del motore (a meno di allarmi che prevedano l'arresto immediato). **Carico** = Il ciclo di raffreddamento viene eseguito solo se il generatore ha assunto il carico. **Soglia Temperatura** = Il ciclo di raffreddamento viene eseguito solo fintanto che la temperatura motore è più elevata della soglia specificata nei parametri seguenti.
P11.18 - Durata massima del ciclo di raffreddamento. Esempio: tempo che intercorre tra la sconnessione del carico dal generatore e l'effettivo arresto del motore.
P11.19 - Temperatura sotto la quale il raffreddamento non viene eseguito o viene interrotto.
P11.20 - Tempo di eccitazione della uscita programmata con la funzione *magnete di stop*.
P11.21 - Tempo che intercorre tra l'attivazione della uscita di *start* (motorino di avviamento) e la attivazione della uscita programmata con la funzione *valvola gas*.
P11.22 - Tempo di eccitazione della uscita programmata con la funzione *cicchetto*.
P11.23 - Tempo di eccitazione della uscita programmata con la funzione *valvola aria* (choke).
P11.24 - Soglia percentuale riferita alla tensione di generatore nominale impostata, superata la quale viene diseccitata l'uscita programmata come *valvola aria*.
P11.25 - Numero di tentativi con *valvola aria* attivata.
P11.26 - Modo comando valvola aria (choke) per motori a benzina. **Consecutivi** = tutti gli avviamenti vengono eseguiti utilizzando la valvola aria. **Alternati** = gli avviamenti avvengono effettuati alternativamente con o senza valvola aria.
P11.27 - Modo comando uscita *start aria compressa*: **OFF** = l'uscita programmata con la funzione *start aria compressa* è disabilitata. **Consecutivi** = La prima metà degli avviamenti viene eseguita con l'uscita di avviamento, la seconda metà con l'uscita programmata come aria compressa. **Alternati** = gli avviamenti avvengono alternativamente con l'attivazione dell'uscita di avviamento oppure con l'uscita *aria compressa*.
P11.28 - Modo comando uscita *Elettrovalvola carburante*: **Normale** = il relé *elettrovalvola carburante* viene disattivato durante le pause fra i tentativi di avviamento. **Continuo** = durante le pause tra un tentativo d'avviamento ed il successivo il relé *elettrovalvola carburante* rimane attivato.
P11.29 - Modo comando uscita *Candelelle preriscaldamento*: **Normale** = l'uscita *candellelle* viene eccitata prima dell'avviamento per la durata impostata. **+Start** = L'uscita *candellelle* rimane attivata anche durante la fase di avviamento. **+Ciclo** = L'uscita *candellelle* rimane attivata durante tutto il ciclo di avviamento.
P11.30 - Modo comando uscita *Magnete di arresto*: **Normale** = l'uscita *magnete di stop* viene attivata durante la fase di arresto e successivamente all'effettivo arresto del motore viene prolungata per il tempo impostato. **Pulse** = l'uscita *magnete di stop* rimane attivata solo durante un impulso temporizzato. **No pausa** = durante la pausa tra un avviamento ed il successivo non viene attivata l'uscita *magnete di stop*. Durante la fase di arresto l'uscita *magnete di stop* rimane attivata sino all'esaurimento del tempo impostato.

P11.16 - Engine temperature above which the deceleration function is disabled.
P11.17 - Cooling cycle mode. **Always** = The cooling cycle runs always every time the engine stops in automatic mode (unless there is an alarm that stops the engine immediately). **Load** = The cooling cycle only runs if the generator has connected to the load. **Temperature threshold** = The cooling cycle is only run for as long as the engine temperature is higher than the threshold specified in the following parameters.
P11.18 - Max. duration of the cooling cycle. Example: time between load disconnection from the generator and when the engine actually stops.
P11.19 - Temperature below which cooling is stopped.
P11.20 - Programmed output energizing time with *stop magnets* function.
P11.21 - Time from the activation of the *start* output (starter motor) and the activation of the output programmed with the function *gas valve*.
P11.22 - Programmed output energizing time with *priming valve* function.
P11.23 - Programmed output energizing time with *choke* function.
P11.24 - Percentage threshold with reference to set rated generator voltage, after which the output programmed as *choke* is de-energized.
P11.25 - Number of attempts with *choke* on.
P11.26 - Choke command mode for petrol engines. **Consecutive** = All starts use the choke. **Alternate** = Alternate starts with and without choke.
P11.27 - *Compressed air start* output command mode: **OFF** = The output programmed with the *compressed air start* function is disabled. **Consecutive** = The first half of the starts are with the starting output, the second half with the output programmed for compressed air. **Alternate** = The starts alternate between activation of the starting output and the output programmed for *compressed air*.
P11.28 - *Fuel solenoid valve* output command mode: **Normal** = The *fuel solenoid valve* relay is disabled between start attempts. **Continuous** = The *fuel solenoid valve* remains enabled between start attempts.
P11.29 - *Glowplug preheating* output command mode: **Normal** = The *glowplugs* output is energized for the set time before starting. **+Start** = The *glowplugs* output remains energized also during the starting phase. **+Cycle** = The *glowplugs* output remains energized also during the starting cycle.
P11.30 - *Stop magnets* output command mode: **Normal** = The *stop magnets* output is energized during the stop phase and continues for the set time after the engine has stopped. **Pulse** = The *stop magnets* output remains energized for a timed pulse only. **No pause** = The *stop magnets* output is not energized between one start and the next. output The *stop magnets* output remains energized during the stop phase for the set time.

M12 - COMMUTAZIONE CARICO		UdM	Default	Range
P12.01	Tempo interblocco rete/generatore	s	0.5	0.0-60.0
P12.02	Ritardo allarme feedback	s	5	1-60
P12.03	Tipo dispositivi di commutazione		Contattori	Contattori Interruttori Commutatori
P12.04	Apertura contatore generatore su avaria elettrica		ON	OFF-ON
P12.05	Tipo di comando interruttori / commutatori		Impulsivo	Impulsivo Continuo
P12.06	Durata impulso apertura	s	10	0-600
P12.07	Durata impulso chiusura	s	1	0-600
P12.08	Comando apertura interruttori		OBP	OBP OAP

P12.01 - Tempo che intercorre tra la avvenuta apertura del dispositivo di commutazione Rete e il comando di chiusura del dispositivo di commutazione Generatore e viceversa.
P12.02 - Tempo massimo per cui il sistema tollera che l'ingresso di feedback dello stato dei dispositivi di commutazione non corrisponda allo stato comandato dalla scheda, in presenza della tensione necessaria al loro movimento. Superato questo tempo, vengono emessi gli allarmi di avaria dispositivo di commutazione.
P12.03 - Scelta tipo dispositivi di commutazione. **Contattori** = Comando con 2 uscite. **Interruttori motorizzati** = comando con 4 uscite (apri-chiudi Rete / apri-chiudi generatore). **Commutatori motorizzati** = comando con 3 uscite (Chiudi rete, Apri entrambe, chiudi generatore).
Nota: Quando si utilizzano interruttori o commutatori motorizzati è obbligatorio utilizzare gli ingressi di feedback.
P12.04 - Se impostato ad ON, In caso di presenza di un qualsiasi allarme con la proprietà *Avaria elettrica* abilitata, il contatore generatore viene aperto.
P12.05 - In casodi utilizzo di interruttori o commutatori motorizzati, i comandi di apertura possono essere: **Impulsivo** = mantenuto per il tempo necessario al compimento della manovra e prolungato del tempo impostato nei due parametri seguenti. **Continuo** = comando di apertura o chiusura mantenuto continuamente.
P12.06 - P12.07 - Tempi di prolungamento del comando di tipo impulsivo (tempi minimi di permanenza del comando).
P12.08 - Definisce la tempistica del comando di apertura interruttori: **OBP (Open Before Presence)** = invia il comando di apertura di un dispositivo *prima* che sia disponibile la tensione sulla sorgente alternativa (esempio: in seguito ad una mancanza rete il comando di apertura interruttore rete è inviato subito, prima che sia disponibile la tensione di generatore). **OAP (Open After Presence)** = Il comando di apertura viene generato solo *dopo* che la tensione della sorgente alternativa si è resa disponibile.

M12 - LOAD CHANGEOVER		UdM	Default	Range
P12.01	Mains/generator interlock time	s	0.5	0.0-60.0
P12.02	Feedback alarm delay	s	5	1-60
P12.03	Switchgear type		Contactors	Contactors Breakers Changeover
P12.04	Generator contactor open for electrical fault		ON	OFF-ON
P12.05	Type of circuit breaker/commutator command		Pulse	Continuous Pulse
P12.06	Opening pulse duration	s	10	0-600
P12.07	Closing pulse duration	s	1	0-600
P12.08	Circuit breakers open command		OBP	OBP OAP

P12.01 - Time from the opening of the Mains switchgear, after which the Generator switchgear closing command is given and vice versa.
P12.02 - Max. time for which the system tolerates that the input of the feedback on the switchgear state fails to correspond to the state controlled by the board, in the presence of the voltage necessary to move the same. Switchgear fault alarms are generated after this time.
P12.03 - Selects the type of switchgear. **Contactors** = Command with 2 outputs. **Motorized circuit breakers** = Command with 4 outputs (open-close Mains/open-close generator). **Motorized changeovers** = Command with 3 outputs (Close Mains, Open both, close generator).
Note: When motorized breakers or changeover are used, the use of feedback inputs is mandatory.
P12.04 - When set to ON, if any alarm with the *Electrical fault* property enabled is active, the generator contactor is opened.
P12.05 - There are the following opening commands for motorized circuit breakers or commutators: **Pulse** = Maintained for the time necessary to complete the manoeuvre and extended for the time set in the two following parameters. **Continuous** = Opening or closing command maintained continuously.
P12.06 - P12.07 - Impulse type command extension times (min. permanence times for the command).
P12.08 - Defines the circuit breakers open command times: **OBP (Open Before Presence)** = Sends the open command to a device *before* there is voltage at the alternative source (for example: following a mains outage, the mains circuit breaker open command is sent immediately, before voltage is supplied by the generator). **OAP (Open After Presence)** = The opening command is only generated *after* voltage from the alternative source is available.

M13 - CONTROLLO TENSIONE RETE		UdM	Default	Range
P13.01	Limite tensione MIN	%	85	70-100
P13.02	Ritardo tensione MIN	s	5	0-600

M13 - MAINS VOLTAGE CONTROL		UdM	Default	Range
P13.01	MIN. voltage limit	%	85	70-100
P13.02	MIN voltage delay	s	5	0-600



P13.03	Limite tensione MAX	%	115	100-130 / OFF
P13.04	Ritardo tensione MAX	s	5	0-600
P13.05	Ritardo rientro rete nei limiti	s	20	1-9999
P13.06	Isteresi limiti MIN/MAX	%	3.0	0.0-5.0
P13.07	Limite asimmetria MAX	%	15	OFF / 5-25
P13.08	Ritardo asimmetria MAX	s	5	0-600
P13.09	Limite frequenza MAX	%	110	100-120/OFF
P13.10	Ritardo frequenza MAX	s	5	0-600
P13.11	Limite frequenza MIN	%	90	OFF/80-100
P13.12	Ritardo frequenza MIN	s	5	0-600
P13.13	Modo controllo RETE		INT	OFF INT EXT
P13.14	Controllo RETE in modo RESET/OFF		OFF	OFF ON OFF+GLOB ON+GLOB
P13.15	Controllo RETE in modo MAN		OFF	OFF ON OFF+GLOB ON+GLOB
P13.16	Tempo ritardo avviamento motore in seguito amancanza rete	s	OFF	OFF / 1-9999
P13.17	Ritardo rete nei limiti se il gruppo non è avviato	s	2	0-999

Nota: Questo menu non è presente nella versione RGK800SA.

- P13.01 – Valore percentuale della soglia d'intervento di minima tensione.
P13.02 – Ritardo all'intervento di minima tensione.
P13.03 – Valore percentuale della soglia d'intervento di massima tensione, disabilitabile.
P13.04 – Ritardo all'intervento di massima tensione.
P13.05 – Ritardo trascorso il quale la tensione di rete viene considerata nei limiti.
P13.06 – Isteresi % calcolata rispetto al valore minimo e massimo impostati, per ripristino tensione nei limiti.
P13.07 – Soglia massima di asimmetria tra le fasi, riferita alla tensione nominale
P13.08 – Ritardo all'intervento per asimmetria.
P13.09 – Soglia (disabilitabile) di intervento di massima frequenza.
P13.10 – Ritardo di intervento di massima frequenza.
P13.11 – Soglia (disabilitabile) di intervento di minima frequenza.
P13.12 – Ritardo di intervento di minima frequenza.
P13.13 – **OFF** = Controllo rete disabilitato. **INT** = Controllo rete affidato all'RGK800.
EXT = Controllo rete affidato ad un apparecchio esterno. E' possibile utilizzare un ingresso programmabile con la funzione *Controllo rete esterno* collegato al dispositivo di controllo rete esterno.
P13.14 – **OFF** = il controllo tensione rete in modalità RESET è disattivato. **ON** = il controllo rete in modalità RESET è attivato. **OFF+GBL** = il controllo rete in RESET è disattivato ma il relé programmato con la funzione allarme globale interviene o meno a seconda che la rete sia rispettivamente assente o presente. **ON+GBL** = il controllo rete in RESET è attivato ed il relé programmato con la funzione allarme globale interviene o meno a seconda che la rete sia rispettivamente assente o presente.
P13.15 – Vedere P13.14 ma riferito alla modalità MANUALE.
P13.16 – Ritardo all'avviamento del motore quando la tensione di rete non rientra nei limiti impostati. Se impostato ad OFF, il ciclo di avviamento inizia contemporaneamente alla apertura del contattore rete.
P13.17 – Ritardo tensione rete nei limiti quando il motore non è ancora avviato.

M14 – CONTROLLO TENSIONE GENERATORE	UdM	Default	Range	
P14.01	Limite tensione MIN	%	80	70-100
P14.02	Ritardo tensione MIN	s	5	0-600
P14.03	Limite tensione MAX	%	115	100-130 / OFF
P14.04	Ritardo tensione MAX	s	5	0-600
P14.05	Ritardo rientro generatore nei limiti	s	20	1-9999
P14.06	Isteresi limiti MIN/MAX	%	3.0	0.0-5.0
P14.07	Limite asimmetria MAX	%	15	OFF / 5-25
P14.08	Ritardo asimmetria MAX	s	5	0-600
P14.09	Limite frequenza MAX	%	110	100-120/OFF
P14.10	Ritardo frequenza MAX	s	5	0-600
P14.11	Limite frequenza MIN	%	90	OFF/80-100
P14.12	Ritardo frequenza MIN	s	5	0-600
P14.13	Modo controllo tensione generatore		INT	OFF INT EXT
P14.14	Tempo ritardo allarme bassa tensione generatore	s	240	1-600
P14.15	Tempo ritardo allarme alta tensione generatore	s	10	1-600

- P14.01 – Valore percentuale della soglia d'intervento di minima tensione.
P14.02 – Ritardo all'intervento di minima tensione.
P14.03 – Valore percentuale della soglia d'intervento di massima tensione, disabilitabile.
P14.04 – Ritardo all'intervento di massima tensione.
P14.05 – Ritardo trascorso il quale la tensione di generatore viene considerata nei limiti.
P14.06 – Isteresi % calcolata rispetto al valore minimo e massimo impostati, per ripristino tensione nei limiti.
P14.07 – Soglia massima di asimmetria tra le fasi, riferita alla tensione nominale
P14.08 – Ritardo all'intervento per asimmetria.
P14.09 – Soglia (disabilitabile) di intervento di massima frequenza.
P14.10 – Ritardo di intervento di massima frequenza.
P14.11 – Soglia (disabilitabile) di intervento di minima frequenza.
P14.12 – Ritardo di intervento di minima frequenza.
P14.13 – **OFF** = Controllo generatore disabilitato. **INT** = Controllo tensione generatore affidato all'RGK800. **EXT** = Controllo generatore affidato ad un apparecchio esterno. E' possibile utilizzare un ingresso programmabile con la funzione *Controllo generatore*

P13.03	MAX. voltage limit	%	115	100-130 / OFF
P13.04	MAX. voltage delay	s	5	0-600
P13.05	Mains restore delay within limits	s	20	1-9999
P13.06	MIN./MAX. limits hysteresis	%	3.0	0.0-5.0
P13.07	MAX. asymmetry limit	%	15	OFF / 5-25
P13.08	MAX. asymmetry delay	s	5	0-600
P13.09	MAX. frequency limit	%	110	100-120/OFF
P13.10	MAX. frequency delay	s	5	0-600
P13.11	MIN. frequency limit	%	90	OFF/80-100
P13.12	MIN. frequency delay	s	5	0-600
P13.13	MAINS control mode		INT	OFF INT EXT
P13.14	MAINS control in RESET/OFF mode		OFF	OFF ON OFF+GLOB ON+GLOB
P13.15	MAINS control in MAN mode		OFF	OFF ON OFF+GLOB ON+GLOB
P13.16	Engine start delay after mains outage	s	OFF	OFF / 1-9999
P13.17	Mains delay if genset hasn't started	s	2	0-999

Note: Menu not present in RGK800SA version.

- P13.01 – Percentage value for minimum voltage intervention threshold.
P13.02 – Minimum voltage intervention delay.
P13.03 – Percentage value for maximum voltage intervention threshold (can be disabled).
P13.04 – Maximum voltage intervention delay.
P13.05 – Delay after which the mains voltage is considered within the limits.
P13.06 – % hysteresis calculated with reference to the minimum and maximum value set, to restore the voltage to within the limits.
P13.07 – Maximum threshold for asymmetry between the phases, with reference to the rated voltage
P13.08 – Asymmetry intervention delay.
P13.09 – Max. frequency intervention threshold (can be disabled).
P13.10 – Max. frequency intervention delay.
P13.11 – Min. frequency intervention threshold (can be disabled).
P13.12 – Min. frequency intervention delay.
P13.13 – **OFF** = Mains control disabled. **INT** = Mains controlled by RGK800.
EXT = Mains controlled by external device. A programmable input can be used with the *External mains control* function connected to the external mains control device.
P13.14 – **OFF** = Mains voltage control in RESET mode disabled. **ON** = Mains control in RESET mode enabled. **OFF+GBL** = Mains control in RESET disabled, but the relay programmed with the global alarm function intervenes or not depending on whether the mains is respectively absent or present. **OFF+GBL** = Mains control in RESET enabled, and the relay programmed with the global alarm function intervenes or not depending on whether the mains is respectively absent or present.
P13.15 – See P13.14 with reference to MANUAL mode.
P13.16 – Engine start delay when mains voltage fails to meet set limits. If set to OFF, the starting cycle starts when the mains contactor opens.
P13.17 – Mains voltage delay within limits - engine hasn't started yet.

M14 - GENERATOR VOLTAGE CONTROL	UdM	Default	Range	
P14.01	MIN. voltage limit	%	80	70-100
P14.02	MIN voltage delay	s	5	0-600
P14.03	MAX. voltage limit	%	115	100-130 / OFF
P14.04	MAX. voltage delay	s	5	0-600
P14.05	Generator voltage return delay within limits	s	20	1-9999
P14.06	MIN./MAX. limits hysteresis	%	3.0	0.0-5.0
P14.07	MAX. asymmetry limit	%	15	OFF / 5-25
P14.08	MAX. asymmetry delay	s	5	0-600
P14.09	MAX. frequency limit	%	110	100-120/OFF
P14.10	MAX. frequency delay	s	5	0-600
P14.11	MIN. frequency limit	%	90	OFF/80-100
P14.12	MIN. frequency delay	s	5	0-600
P14.13	Generator voltage control mode		INT	OFF INT EXT
P14.14	Generator voltage low alarm delay	s	240	1-600
P14.15	Generator voltage high alarm delay	s	10	1-600

- P14.01 – Percentage value for minimum voltage intervention threshold.
P14.02 – Minimum voltage intervention delay.
P14.03 – Percentage value for maximum voltage intervention threshold (can be disabled).
P14.04 – Maximum voltage intervention delay.
P14.05 – Delay after which the generator voltage is considered within the limits.
P14.06 – % hysteresis calculated with reference to the minimum and maximum value set, to restore the voltage to within the limits.
P14.07 – Maximum threshold for asymmetry between the phases, with reference to the rated voltage
P14.08 – Asymmetry intervention delay.
P14.09 – Max. frequency intervention threshold (can be disabled).
P14.10 – Max. frequency intervention delay.
P14.11 – Min. frequency intervention threshold (can be disabled).
P14.12 – Min. frequency intervention delay.
P14.13 – **OFF** = Generator control disabled. **INT** = Generator controlled by RGK800. **EXT** = Generator controlled by external device. A programmable input can be used with the

esterno collegato al dispositivo di controllo generatore esterno.
P14.14 – Ritardo per l'allarme *A28 Bassa tensione generatore*.
P14.15 – Ritardo per l'allarme *A29 Alta tensione generatore*.

External mains control function connected to the external generator control device.
P14.14 – *A28 Low generator voltage alarm delay.*
P14.15 – *A29 High generator voltage alarm delay.*

M15 – PROTEZIONE GENERATORE	UdM	Default	Range
P15.01 Soglia limite allarme corrente max.	%	OFF	100-500/OFF
P15.02 Ritardo intervento corrente max	s	4.0	0.0-60.0
P15.03 Soglia limite allarme cortocircuito	%	OFF	100-500/OFF
P15.04 Ritardo intervento cortocircuito	s	0.02	0.00-10.00
P15.05 Tempo ripristino protezione	s	60	0-5000
P15.06 Classe di protezione termica		OFF	OFF P1 P2 P3 P4
P15.07 Tempo di ripristino protezione termica	s	60	0-5000
P15.08 Soglia corrente allarme guasto a terra	A	OFF	OFF / 0.03 - 30.00
P15.09 Ritardo allarme guasto a terra	s	0.02	0.00-60.00

P15.01 – Soglia percentuale riferita alla corrente nominale impostata per la generazione dell'allarme **Errore. L'origine riferimento non è stata trovata.** *Massima corrente generatore.*
P15.02 – Ritardo intervento per la soglia del parametro precedente.
P15.03 – Soglia percentuale riferita alla corrente nominale impostata per la generazione dell'allarme **Errore. L'origine riferimento non è stata trovata.** *Corto circuito generatore.*
P15.04 – Ritardo intervento per la soglia del parametro precedente.
P15.05 – Tempo dopo il quale è possibile ripristinare l'allarme di protezione termica.
P15.06 – Scelta di una delle possibili curve di protezione termica integrale del generatore. Le curve possono essere impostate tramite il software di programmazione *Customization manager*. Se impostato, abilita la visualizzazione della pagina con lo stato termico del generatore.
P15.07 – Tempo minimo necessario al ripristino dopo l'intervento di una protezione termica.
P15.08 – Soglia di intervento dell'allarme **Errore. L'origine riferimento non è stata trovata.** *Guasto a terra.* Se impostato, abilita la visualizzazione della corrispondente pagina sul display.
P15.09 – Ritardo intervento per la soglia del parametro precedente.

M15 - GENERATOR PROTECTION	UdM	Default	Range
P15.01 Max. current alarm limit threshold	%	OFF	100-500/OFF
P15.02 Max. current intervention delay	s	4.0	0.0-60.0
P15.03 Short-circuit alarm limit threshold	%	OFF	100-500/OFF
P15.04 Short-circuit intervention delay	s	0.02	0.00-10.00
P15.05 Protection reset time	s	60	0-5000
P15.06 Protection class		OFF	OFF P1 P2 P3 P4
P15.07 Thermal protection reset time	s	60	0-5000
P15.08 Ground fault alarm current threshold	A	OFF	OFF / 0.03 - 30.00
P15.09 Ground fault alarm delay	s	0.02	0.00-60.00

P15.01 – Percentage threshold with reference to the rated current set for activating the *Max. generator current* alarm.
P15.02 – Previous parameter threshold intervention delay.
P15.03 – Percentage threshold with reference to the rated current set for activating the *Generator short-circuit* alarm.
P15.04 – Previous parameter threshold intervention delay.
P15.05 – Time after which the thermal protection alarm can be reset.
P15.06 – Selects one of the possible integral thermal protection curves for the generator. The curves can be custom set using the *Customisation manager* software . If set, this enables displaying the page with the thermal state of the generator.
P15.07 – Min. time required for reset after thermal protection tripped.
P15.08 – Intervention threshold for *Earth fault* alarm. If set this enables displaying the corresponding page on the display.
P15.09 – Previous parameter threshold intervention delay.

M16 – TEST AUTOMATICO	UdM	Default	Range
P16.01 Abilitazione TEST automatico		OFF	OFF / ON
P16.02 Intervallo tra i TEST	gg	7	1-60
P16.03 Abilitazione TEST al lunedì		ON	OFF / ON
P16.04 Abilitazione TEST al martedì		ON	OFF / ON
P16.05 Abilitazione TEST al mercoledì		ON	OFF / ON
P16.06 Abilitazione TEST al giovedì		ON	OFF / ON
P16.07 Abilitazione TEST al venerdì		ON	OFF / ON
P16.08 Abilitazione TEST al sabato		ON	OFF / ON
P16.09 Abilitazione TEST alla domenica		ON	OFF / ON
P16.10 Ora inizio TEST	h	12	00-23
P16.11 Minuti inizio TEST	min	00	00-59
P16.12 Durata del TEST	min	10	1-600
P16.13 TEST automatico con commutazione del carico		OFF	OFF Carico Carico fittizio
P16.14 Esecuzione TEST automatico anche con stop esterno attivato		OFF	OFF/ON

P16.01 – Attiva l'esecuzione del test periodico. Questo parametro può essere modificato direttamente dal frontale senza accedere al setup (vedere capitolo Test Automatico) ed il suo stato corrente è visualizzato nella apposita pagina del display.
P16.02 – Tempo d'intervallo tra un test periodico ed il successivo. Se nel giorno della scadenza del periodo il test non è abilitato, l'intervallo verrà allungato di conseguenza al successivo giorno abilitato.
P16.03...P16.09 Abilita l'esecuzione del test automatico nei singoli giorni della settimana. OFF significa che in quel giorno il test non verrà eseguito. Attenzione!! L'orologio datario deve essere impostato correttamente.
P16.10 – **P16.11** Stabilisce l'ora e i minuti di inizio del test periodico. Attenzione!! L'orologio datario deve essere impostato correttamente.
P16.12 – Durata in minuti del test periodico
P16.13 – Gestione del carico durante l'esecuzione del test periodico: **OFF** = Il carico non viene commutato. **Carico** = Abilita la commutazione del carico dalla rete al generatore. **Carico fittizio** = Viene inserito il carico fittizio, mentre il carico dell'impianto non viene commutato.
P16.14 – Esegue il test periodico anche se l'ingresso programmato con la funzione Stop esterno risulta attivato.

M16 - AUTOMATIC TEST	UdM	Default	Range
P16.01 Enable automatic TEST		OFF	OFF / ON
P16.02 Time interval between TESTS	dd	7	1-60
P16.03 Enable TEST on Monday		ON	OFF / ON
P16.04 Enable TEST on Tuesday		ON	OFF / ON
P16.05 Enable TEST on Wednesday		ON	OFF / ON
P16.06 Enable TEST on Thursday		ON	OFF / ON
P16.07 Enable TEST on Friday		ON	OFF / ON
P16.08 Enable TEST on Saturday		ON	OFF / ON
P16.09 Enable TEST on Sunday		ON	OFF / ON
P16.10 TEST start time	h	12	00-23
P16.11 TEST start minutes	min	00	00-59
P16.12 TEST duration	min	10	1-600
P16.13 Automatic TEST with load switching		OFF	OFF Load Dummy load
P16.14 Automatic TEST run also with external stop enabled		OFF	OFF/ON

P16.01 – Enable periodic test. This parameter can be changed directly on the front panel without using setup (see chapter Automatic Test) and its current state is shown on the relevant page of the display.
P16.02 – Time interval between one periodic test and the next. If the test isn't enabled the day the period expires, the interval will be extended to the next enabled day.
P16.03...P16.09 Enables the automatic test in each single day of the week. OFF means the test will not be performed on that day. Warning!! The calendar clock must be set to the right date and time.
P16.10 – **P16.11** Sets the time (hour and minutes) when the periodic test starts. Warning!! The calendar clock must be set to the right date and time.
P16.12 – Duration in minutes of the periodic test
P16.13 – Load management during the periodic test: **OFF** = The load will not be switched. **Load** = Enables switching the load from the mains to the generator. **Dummy load** = The dummy load is switched in, and the system load will not be switched.
P16.14 – Runs the periodic test even if the input programmed with the External stop function is enabled.

M17 – MANUTENZIONE (MNTn, n=1...3)	UdM	Default	Range
P17.n.01 Intervallo di manutenzione n	h	OFF	OFF/1-99999
P17.n.02 Conteggio intervallo manutenzione n		Ore motore	Ore assolute Ore motore Ore carico

Nota: Questo menu è diviso in 3 sezioni, riferite ai 3 intervalli di manutenzione indipendenti MNT1...MNT3.
P17.n.01 – Definisce il periodo di manutenzione programmata, espresso in ore. Se impostato ad OFF, questo intervallo di manutenzione è disabilitato.
P17.n.02 – Definisce come deve essere contato il trascorrere del tempo per l'intervallo di manutenzione specifico: **Ore Assolute** = Viene contato il tempo effettivo trascorso dalla data della precedente manutenzione. **Ore motore** = Vengono contate le ore di

M17 - MAINTENANCE (MNTn, n=1...3)	UdM	Default	Range
P17.n.01 Service interval n	h	OFF	OFF/1-99999
P17.n.02 Service interval n count		Engine hours	Absolute hrs Engine hrs Load hrs

Note: This menu is divided into 3 sections, which refer to 3 independent service intervals MNT1...MNT3.
P17.n.01 – Defines the programmed maintenance period, in hours. If set to OFF, this service interval is disabled.
P17.n.02 – Defines how the time should be counted for the specific maintenance interval: **Absolute hours** = The actual time that elapsed from the date of the previous service. **Engine hours** = The operating hours of the engine. **Load hours** = The

funzionamento del motore. **Ore carico** = Vengono contate le ore in cui il generatore ha alimentato il carico.

hours for which the generator supplied the load.

M18 – INGRESSI PROGRAMMABILI (INPn, n=1...16)		UdM	Default	Range
P18.n.01	Funzione Ingresso INPn		(varie)	(Vedi Tabella funzioni ingressi)
P18.n.02	Indice funzione (x)		OFF	OFF / 1...99
P18.n.03	Tipo contatto		NO	NO/NC
P18.n.04	Ritardo chiusura	s	0.0	0.0-6000.0
P18.n.05	Ritardo apertura	s	0.0	0.0-6000.0

Nota: Questo menu è diviso in 16 sezioni, riferite ai 16 possibili ingressi digitali INP1...INP16 gestibili dall'RGK800, di cui INP1...INP8 sulla scheda base e INP9...INP16 sugli eventuali moduli di espansione.

P18.n.1 – Scelta della funzione dell'ingresso selezionato (vedi tabella funzioni ingressi programmabili).

P18.n.2 – Indice eventualmente associato alla funzione programmata al parametro precedente. Esempio: Se la funzione dell'ingresso è impostata su *Esecuzione menu comandi Cxx*, e si vuole far sì che questo ingresso esegua il comando C.07 del menu comandi, allora P18.n.02 va impostato al valore 7.

P18.n.3 – Scelta del tipo di contatto NO normalmente aperto o NC normalmente chiuso.

P18.n.4 – Ritardo alla chiusura del contatto sull'ingresso selezionato.

P18.n.5 – Ritardo all'apertura del contatto sull'ingresso selezionato.

M18 - PROGRAMMABLE INPUTS (INPn, n=1...16)		UdM	Default	Range
P18.n.01	INPn input function		(various)	(see Input functions table)
P18.n.02	Function index (x)		OFF	OFF / 1...99
P18.n.03	Contact type		NO	NO/NC
P18.n.04	Closing delay	s	0.0	0.0-6000.0
P18.n.05	Opening delay	s	0.0	0.0-6000.0

Note: This menu is divided into 16 sections that refer to 16 possible digital inputs INP1...INP16, which can be managed by the RGK800; INP1...INP8 on the base board and INP9...INP16 on any installed expansion modules.

P18.n.1 – Selects the functions of the selected input (see programmable inputs functions table).

P18.n.2 – Index associated with the function programmed in the previous parameter. Example: If the input function is set to *Cxx commands menu execution*, and you want this input to perform command C.07 in the commands menu, P18.n.02 should be set to value 7.

P18.n.3 – Select type of contact: NO (Normally Open) or NC (Normally Closed).

P18.n.4 – Contact closing delay for selected input.

P18.n.5 – Contact opening delay for selected input.

M19 – USCITE PROGRAMMABILI (OUTn, n=1...16)		UdM	Default	Range
P19.n.01	Funzione uscita OUTn		(varie)	(Vedi Tabella funzioni uscite)
P19.n.02	Indice funzione (x)		OFF	OFF / 1...99
P19.n.03	Uscita normale / inversa		NOR	NOR / REV

Nota: Questo menu è diviso in 16 sezioni, riferite alle 16 possibili uscite digitali OUT1...OUT16 gestibili dall'RGK800, di cui OUT1...OUT10 sulla scheda base e OUT11...OUT16 sugli eventuali moduli di espansione.

P19.n.1 – Scelta della funzione della uscita selezionata (vedi tabella funzioni uscite programmabili).

P19.n.2 – Indice eventualmente associato alla funzione programmata al parametro precedente. Esempio: Se la funzione dell'uscita è impostata sulla funzione *Allarme Axx*, e si vuole far sì che questa uscita si ecciti quando si verifica l'allarme A31, allora P19.n.02 va impostato al valore 31.

P19.n.3 – Imposta lo stato della uscita quando la funzione ad essa associata non è attiva:
NOR = uscita diseccitata, REV = uscita eccitata.

M19 - PROGRAMMABLE OUTPUTS (OUTn, n=1...16)		UdM	Default	Range
P19.n.01	Output function OUTn		(various)	(see Output functions table)
P19.n.02	Function index (x)		OFF	OFF / 1...99
P19.n.03	Normal/reverse output		NOR	NOR / REV

Note: This menu is divided into 16 sections that refer to 16 possible digital outputs OUT1...OUT16, which can be managed by the RGK800; OUT1...OUT10 on the base board and OUT11...OUT16 on any installed expansion modules.

P19.n.1 – Selects the functions of the selected output (see programmable outputs functions table).

P19.n.2 – Index associated with the function programmed in the previous parameter. Example: If the output function is set to *Alarm Axx*, and you want this output to be energized for alarm A31, then P19.n.02 should be set to value 31.

P19.n.3 – Sets the state of the output when the function associated with the same is inactive:
NOR = output de-energized, REV = output energized.

M20 – COMUNICAZIONE (COMn, n=1...3)		UdM	Default	Range
P20.n.01	Indirizzo seriale nodo		01	01-255
P20.n.02	Velocità seriale	bps	9600	1200 2400 4800 9600 19200 38400 57600 115200
P20.n.03	Formato dati		8 bit – n	8 bit, no parità 8 bit, dispari 8 bit, pari 7 bit, dispari 7 bit, pari
P20.n.04	Bit di stop		1	1-2
P20.n.05	Protocollo		(varie)	Modbus RTU Modbus ASCII Modbus TCP Propri. ASCII
P20.n.06	Indirizzo IP		192.168.1.1	000.000.000.0 00 – 255.255.255.2 55
P20.n.07	Subnet mask		0.0.0.0	000.000.000.0 00 – 255.255.255.2 55
P20.n.08	Porta IP		1001	0-9999
P20.n.09	Funzione canale		Slave	Slave Gateway Mirror

Nota: questo menu è diviso in 3 sezioni, per i canali di comunicazione COM1...3. Il canale COM1 identifica la porta RS-485 di serie, mentre COM2 e COM3 sono riservate alle eventuali porte di comunicazione su moduli di espansione EXP. La porta di programmazione frontale a infrarossi ha parametri di comunicazione fissi e quindi non necessita di alcun menu di impostazione.

P20.n.01 – Indirizzo seriale (nodo) del protocollo di comunicazione.

P20.n.02 – Velocità di trasmissione della porta di comunicazione.

P20.n.03 – Formato dati. Impostazioni a 7 bit possibili solo per protocollo ASCII.

P20.n.04 – Numero bit di stop.

P20.n.05 – Scelta del protocollo di comunicazione.

P20.n.06, P20.n.07, P20.n.08 – Coordinate TCP-IP per applicazioni con interfaccia Ethernet. Non utilizzati con altri tipi di moduli di comunicazione.

M20 - COMMUNICATION (COMn, n=1...3)		UdM	Default	Range
P20.n.01	Node serial address		01	01-255
P20.n.02	Serial speed	bps	9600	1200 2400 4800 9600 19200 38400 57600 115200
P20.n.03	Data format		8 bit – n	8 bit, no parity 8 bit, odd 8 bit, even 7 bit, odd 7 bit, even
P20.n.04	Stop bits		1	1-2
P20.n.05	Protocol		(various)	Modbus RTU Modbus ASCII Modbus TCP Propri. ASCII
P20.n.06	IP address		192.168.1.1	000.000.000.0 00 – 255.255.255.2 55
P20.n.07	Subnet mask		0.0.0.0	000.000.000.0 00 – 255.255.255.2 55
P20.n.08	IP port		1001	0-9999
P20.n.09	Channel function		Slave	Slave Gateway Mirror

Note: this menu is divided into 3 sections for communication channels COM1...3. Channel COM1 identifies serial port RS-485, while COM2 and COM3 are for any communications ports on EXP expansion modules. The front IR communication port has fixed communication parameters, so no setup menu is required.

P20.n.01 – Serial (node) address of the communication protocol.

P20.n.02 – Communication port transmission speed.

P20.n.03 – Data format. 7 bit settings can only be used for ASCII protocol.

P20.n.04 – Stop bit number.

P20.n.05 – Select communication protocol.

P20.n.06, P20.n.07, P20.n.08 – TCP-IP coordinates for applications with Ethernet interface. Not used with other types of communication modules.

P20.n.09 – Modo di funzionamento della porta. **Slave** = funzionamento normale, l'apparecchio risponde ai messaggi di un master esterno. **Gateway** = L'apparecchio analizza in locale i messaggi a lui destinati (indirizzo seriale) e invece inoltra attraverso la interfaccia RS485 quelli destinati ad altri nodi. Vedere capitolo *Canali di comunicazione*. **Mirror** = il canale di comunicazione è utilizzato per il collegamento di un pannello ripetitore RGKRD.

P20.n.09 – Port function mode. **Slave** = Normal operating mode, the device answers the messages sent by an external master. **Gateway** = The device analyses messages received locally (sent to its serial address) and forwards those addressed to other nodes through the RS485 interface. See chapter *Communication channels*. **Mirror** = The communication channel is used for connection to a RGKRD repeater panel.

M21 - CANBUS	UdM	Default	Range
P21.01	Tipo ECU Motore	OFF	OFF GENERIC J1939 VOLVO EDC VOLVO EMS VOLVO EMS2 SCANIA S6 DEUTZ EMR2 PERKINS 2800 JOHN DEERE IVECO NEF IVECO CURSOR
P21.02	Modo operativo ECU	M	M M+E M+E+T M+E+T+C
P21.03	Alimentazione ECU	ON	OFF-1...600-ON
P21.04	Ridirezione allarmi da CAN	OFF	OFF-ON
<p>P21.01 - Scelta del tipo di ECU del motore. Se la ECU che si intende utilizzare non fa parte della lista di quelle possibili, scegliere <i>Generic J1939</i>. In questo caso l'RGK800 analizza solo i messaggi sul CAN che aderiscono alla norma SAE J1939.</p> <p>P21.02 - Modo di comunicazione sul CAN bus. M = solo Misure. L' RGK800 cattura solo le misure (pressioni, temperature ecc) inviate sul CAN dalla ECU del motore. M+E – Oltre a leggere le misure, l'RGK800 cattura e visualizza i messaggi diagnostici e di allarme emessi dalla ECU. M+E+T – Come precedente, ma in più l'RGK800 trasmette sul CANbus i comandi necessari per l'azzeramento della diagnostica ecc. M+E+T+C = Come precedente, ma in più vengono anche gestiti i comandi di start/stop motore via CANbus.</p> <p>P21.03 - Tempo di prolungamento della alimentazione della ECU tramite l'uscita programmata con la funzione <i>Alimentazione ECU</i>, dopo che l'elettrovalvola carburante è stata diseccitata. Questo è anche il tempo per il quale viene alimentata la ECU dopo che sono stati premuti dei tasti sulla tastiera frontale, in modo da poter leggere le misure da essa fornite.</p> <p>P21.04 - Alcuni degli allarmi principali vengono generati tramite messaggio CAN invece che in modo tradizionale. OFF = gli allarmi (olio, temperatura ecc.) sono gestiti in modo standard. Le segnalazioni diagnostiche della ECU sono visualizzate sulla apposita pagina <i>Diagnostica CAN</i>. Di solito tutti gli allarmi da CAN generano anche i cumulativi <i>Lampada gialla</i> (preallarme) o <i>Lampada rossa</i> (allarme critico), gestibili con le loro proprietà. ON = I messaggi diagnostici da CAN che hanno un diretto corrispondente nella tabella allarmi generano anche questo allarme, oltre ai consueti lampada gialla e lampada rossa. Vedere il capitolo sugli allarmi per la lista di quelli ridirezionabili.</p>			

M21 - CANBUS	UdM	Default	Range
P21.01	Engine ECU type	OFF	OFF GENERIC J1939 VOLVO EDC VOLVO EMS VOLVO EMS2 SCANIA S6 DEUTZ EMR2 PERKINS 2800 JOHN DEERE IVECO NEF IVECO CURSOR
P21.02	ECU operating mode	M	M M+E M+E+T M+E+T+C
P21.03	ECU power input	ON	OFF-1...600-ON
P21.04	CAN alarms redirect	OFF	OFF-ON
<p>P21.01 - Selects the type of engine ECU. If the ECU you wish to use can't be found in the list of possible choices, select <i>Generic J1939</i>. In this case, the RGK800 only analyses messages on the CAN that meet SAE J1939 standards.</p> <p>P21.02 - Communication mode on CAN bus. M = Measurements only. The RGK800 only captures the measurements (pressures, temperatures, etc.) sent to the CAN by the engine ECU. M+E – As well as the measurements, the RGK800 captures and displays the diagnostic and alarm messages of the ECU. M+E+T – As above, but the RGK800 also sends the commands for resetting diagnostics, etc. to the CANbus. M+E+T+C = As above, but engine start/stop commands are also managed via CANbus.</p> <p>P21.03 - ECU power extension time through the output programmed with the function <i>ECU Power</i>, after the solenoid valve has been de-energized. This is also the time for which the ECU is powered after the keys have been pressed on the front keyboard, to read the measurements sent by the same.</p> <p>P21.04 - Some of the main alarms are generated by a CAN message, instead of in the traditional way. OFF = The alarms (oil, temperature, etc.) are managed in the standard way. The ECU diagnostic reports are displayed on the page <i>CAN Diagnostics</i>. Usually all the CAN alarms also generate the cumulative <i>Yellow lamp</i> (prealarm) or <i>Red lamp</i> (critical alarm), which can be managed with their properties. ON = CAN diagnostics messages with a direct correspondence in the alarms table also generate this alarm, as well as activating the yellow and red lamp. See the alarms chapter for the list of redirectable alarms.</p>			

M22 - GESTIONE CARICO	UdM	Default	Range
P22.01	Avviamento su soglia potenza kW	OFF	OFF-ON
P22.02	Soglia avviamento generatore	kW	0-9999
P22.03	Ritardo soglia avviamento	s	0-9999
P22.04	Soglia arresto	kW	0-9999
P22.05	Ritardo soglia arresto	s	0-9999
P22.06	Gestione carico fittizio (<i>dummy load</i>)	OFF	OFF 1 STEP 2 STEP 3 STEP 4 STEP
P22.07	Soglia inserimento step dummy load	kW	0-9999
P22.08	Ritardo inserimento dummy load	s	0-9999
P22.09	Soglia sgancio step dummy load	kW	0-9999
P22.10	Ritardo sgancio dummy load	s	0-9999
P22.11	Tempo ON dummy load	min	OFF/1-600
P22.12	Tempo OFF dummy load	min	OFF/1-600
P22.13	Gestione sgancio carichi (<i>load shedding</i>)	OFF	OFF 1 STEP 2 STEP 3 STEP 4 STEP
P22.14	Soglia inserimento step load shedding	kW	0-9999
P22.15	Ritardo inserimento load shedding	s	0-9999
P22.16	Soglia sgancio step load shedding	kW	0-9999
P22.17	Ritardo sgancio load shedding	s	0-9999
P22.18	Soglia allarme kW max	%	OFF/1-250
P22.19	Ritardo soglia kW max	s	0-9999
<p>P22.01...P22.05 - Utilizzati per avviare il generatore quando il carico supera una soglia in kW misurata sul ramo rete, normalmente con lo scopo di non eccedere il limite massimo concesso dall'ente fornitore di energia, alimentando il carico con il generatore. Quando il carico scende sotto la soglia di P22.04, il generatore viene arrestato ed il carico ricommutato sulla rete.</p> <p>P22.06 - Abilitazione gestione carico fittizio e definizione del numero di gradini (step) da cui esso è composto. Quando il carico sul generatore è troppo basso, vengono inseriti dei carichi fittizi per il numero massimo di step qui impostati, secondo una logica incrementale.</p> <p>P22.07...P22.10 - Soglie e ritardi per la inserzione o la disinserzione di uno step del carico fittizio.</p> <p>P22.11...P22.12 - Se abilitati, fanno sì che il carico fittizio venga inserito e disinserto ciclicamente con i periodi definiti da questi parametri.</p> <p>P22.13 - Abilitazione gestione sgancio carichi non prioritari (<i>load shedding</i>) e definizione del</p>			

M22 - LOAD MANAGEMENT	UdM	Default	Range
P22.01	Start-up on power threshold kW	OFF	OFF-ON
P22.02	Generator start-up threshold	kW	0-9999
P22.03	Start-up threshold delay	s	0-9999
P22.04	Stop threshold	kW	0-9999
P22.05	Stop threshold delay	s	0-9999
P22.06	Dummy load management (<i>dummy load</i>)	OFF	OFF 1 STEP 2 STEP 3 STEP 4 STEP
P22.07	Dummy load step switch-in threshold	kW	0-9999
P22.08	Dummy load switch-in delay	s	0-9999
P22.09	Dummy load step switch-out threshold	kW	0-9999
P22.10	Dummy load switch-out delay	s	0-9999
P22.11	Dummy load ON time	min	OFF/1-600
P22.12	Dummy load OFF time	min	OFF/1-600
P22.13	Load shedding (<i>load shedding</i>)	OFF	OFF 1 STEP 2 STEP 3 STEP 4 STEP
P22.14	Load shedding step switch-in threshold	kW	0-9999
P22.15	Load shedding switch-in delay	s	0-9999
P22.16	Load shedding step switch-out threshold	kW	0-9999
P22.17	Load shedding switch-out delay	s	0-9999
P22.18	Max. kW alarm threshold	%	OFF/1-250
P22.19	Max. kW alarm delay	s	0-9999
<p>P22.01...P22.05 - Used to start the generator when the load exceeds a threshold in kW measured on a branch of the mains, normally to prevent exceeding the maximum limit set by the energy provider supplying the load with the generator. When the load drops to below P22.04, the generator is stopped and the load is switched back to the mains.</p> <p>P22.06 - Enable dummy load management, setting the number of steps for the same. When the generator load is too low, dummy loads are switched in for the maximum number of steps set on the basis of incremental logic.</p> <p>P22.07...P22.10 - Thresholds and delays for switching-in or switching-out a dummy load step.</p> <p>P22.11...P22.12 - If enabled, the dummy load will be switched in and out cyclically at the time intervals defined by these parameters.</p> <p>P22.13 - Enable non-priority load switch-out (<i>load shedding</i>) defining the number of load sections to disconnect. When the load on the generator is too high, non-priority loads are disconnected in various sections, on the basis of incremental logic.</p>			

numero di sezioni di carico scollegabili. Quando il carico sul generatore è troppo alto, vengono sezionati dei carichi non prioritari in varie sezioni, secondo una logica incrementale.

P22.14...P22.17 - Soglie e ritardi per la disinserzione o la inserzione di una sezione di carico non prioritario.

P22.18...P22.19 - Soglia e ritardo per la generazione dell'allarme A35 *Superamento soglia kW generatore*.

P22.14...P22.17 - Thresholds and delays for switching-out or switching-in a non-priority load section.

P22.18...P22.19 - Thresholds and delays for generating the alarm A35 *Generator kW threshold exceeded*.

M23 - VARIE	UdM	Default	Range
P23.01 Pre-carica ore di noleggjo	h	OFF	OFF/1-99999
P23.02 Modo conteggio ore noleggjo		Ore motore	Ore assolute Ore motore Ore carico
P23.03 Abilitazione ingresso emergenza		ON	OFF/ON
P23.04 Funzione mutual stand-by		OFF	OFF COM1 COM2 COM3
P23.05 Modo alternanza mutual stand-by		Start	Start Tempo
P23.06 Tempo di alternanza mutual stand-by	h	12	1-1000
P23.07 Modo remotazione allarmi		OFF	OFF OUT CAN
P23.08 Modo funzionamento EJP		Normale	Normale EJP EJP-T SCR
P23.09 Ritardo avviamento EJP	min	25	0-240
P23.10 Ritardo commutazione EJP	min	5	0-240
P23.11 Blocco ricommutazione EJP		ON	OFF/ON
P23.12 Start su allarme feedback rete		OFF	OFF/ON
P23.13 Uscita modalità operativa		OFF	OFF O M O+M ...
P23.14 Analisi armonica			OFF THD HAR

P23.01 - Numero di ore di noleggjo da pre-caricare nel contatore quando viene eseguito il comando *C14 Ricarica ore noleggjo*.

P23.02 - Modo decremento del contatore ore di noleggjo. Quando questo contatore arriva a zero, viene generato l'allarme *A48 Ore di noleggjo esaurite*. **Ore assolute** = Decremento in base al tempo reale trascorso. **Ore motore** = Ore di funzionamento del motore. **Ore carico** = Ore di alimentazione carico.

P23.03 - Abilitazione dell'ingresso di emergenza incorporato nel morsetto +COM1, comune positivo delle uscite OUT1 e OUT2 (funzione di default: EV carburante e Start). **ON** = Quando +COM1 viene scollegato dal positivo della batteria, viene generato automaticamente l'allarme *A23 Arresto di emergenza*. **OFF** = scollegando +COM1 dal positivo batteria non viene generato alcun allarme.

P23.04 - Abilitazione della funzione *Mutual stand-by* e definizione della porta di comunicazione utilizzata per il collegamento con il generatore alternativo.

P23.05 - Modo alternanza dei gruppi per la funzione *mutualstand-by*. **Start** = l'alternanza fra i gruppi avviene ad ogni nuova richiesta di intervento. In caso di necessità viene avviato il gruppo con il minor numero di ore di funzionamento, ed esso rimane in moto fino a che non è più necessaria la marcia (le condizioni che hanno determinato l'avviamento vengono meno). **Tempo** = In caso di necessità viene avviato il gruppo con il minor numero di ore di funzionamento, ed esso rimane in moto fino a che le sue ore non superano le ore del gruppo alternativo di una quantità uguale o superiore a quella programmata con il parametro seguente. Quando questa condizione si verifica, il carico viene passato da un gruppo all'altro.

P23.06 - Scostamento massimo fra le ore di funzionamento dei gruppi in *mutual stand-by*. Vedere parametro precedente.

P23.07 - Tipo di collegamento fra RGK800 e unità remotazione relè RGKRR. **OFF** = comunicazione disabilitata. **OUT** = Comunicazione tramite una uscita programmabile impostata sulla funzione *Remotazione allarmi*, collegata all'ingresso digitale dell'RGKRR. **CAN** = RGK800 e RGKRR comunicano attraverso interfaccia CAN. Salvo diversa indicazione per una ECU specifica, è normalmente possibile comunicare contemporaneamente con RGKRR ed ECU motore sulla stessa linea CAN. Vedere manuale operativo RGKRR per maggiori dettagli.

P23.08 - **Normale** = Modalità standard di funzionamento in modalità AUT. **EJP** = vengono utilizzati 2 ingressi programmabili impostati con le funzioni *Avviamento a distanza* e *Telecommutazione* per il funzionamento come EJP. Quando si chiude l'ingresso di avviamento viene attivato il tempo ritardo avviamento motore (P23.09) al termine del quale viene eseguito il ciclo di avviamento. Successivamente, al sopraggiungere del consenso di telecommutazione, se il motore è partito regolarmente, il carico viene commutato dalla rete al generatore. Il carico ritorna sulla rete all'apertura del consenso telecommutazione ed il gruppo esegue il ciclo di arresto all'apertura dell'ingresso di start. La funzione EJP è abilitata solo se il sistema è in modalità automatico. Le protezioni e gli allarmi funzionano come di consueto. **EJP-T** = La funzione EJP/T è una variante semplificata della precedente EJP, dove la partenza del motore viene comandata in modo identico, ma la commutazione del carico avviene a tempo anziché con un segnale esterno apposito. Questa funzione impiega quindi un solo ingresso digitale, cioè quello di avviamento. Il tempo di ritardo per effettuare la commutazione parte da quando viene chiuso il comando di avviamento, ed è impostabile tramite il parametro P23.10 *Ritardo di commutazione*. **SCR** = La funzione SCR è molto simile alla funzione EJP. In questa modalità l'ingresso di avviamento abilita la partenza del gruppo come in EJP, ma senza attendere il tempo di ritardo P23.09. L'ingresso di telecommutazione ha ancora la funzione di consenso alla commutazione che avviene dopo il *Ritardo commutazione* P23.10.

P23.09 - Ritardo fra la chiusura del segnale EJP di avviamento del generatore e l'inizio del

M23 - MISCELLANEOUS	UdM	Default	Range
P23.01 Rent hours pre-charge	h	OFF	OFF/1-99999
P23.02 Rent hours calculation method			
P23.03 Enable emergency input		ON	OFF/ON
P23.04 Mutual stand-by function		OFF	OFF COM1 COM2 COM3
P23.05 Mutual stand-by alternating mode		Start	Start Time
P23.06 Mutual stand-by alternating time	h	12	1-1000
P23.07 Remote alarms mode		OFF	OFF OUT CAN
P23.08 EJP function mode		Normal	Normal EJP EJP-T SCR
P23.09 EJP starting delay	min	25	0-240
P23.10 EJP switching delay	min	5	0-240
P23.11 ELP re-switching block		ON	OFF/ON
P23.12 Start on mains feedback alarm		OFF	OFF/ON
P23.13 Operating mode output		OFF	OFF O M O+M ...
P23.14 Harmonic analysis			OFF THD HAR

P23.01 - Number of rent hours to pre-charge in the counter on command *C14 Recharge rent hours*.

P23.02 - Rent hours counter down count mode. When this counter reaches zero, the *A48 Rent hours expired* alarm is generated. **Absolute hours** = Decreasing count on the basis of the real time expired. **Engine hours** = The operating hours of the engine. **Load hours** = Hours supplying load.

P23.03 - Enable emergency input incorporated in terminal +COM1, common positive of outputs OUT1 and OUT2 (default function: Start and fuel solenoid valve). **ON** = When +COM1 is disconnected from the positive terminal of the battery, the *A23 Emergency stop* alarm is automatically generated. **OFF** = When +COM1 is disconnected from battery terminal, no alarm is generated.

P23.04 - Enables *Mutual stand-by* function and defines the communication port used to connect to an alternative generator.

P23.05 - Alternating genset mode for mutual stand-by function. **Start** = The gensets alternate with every request for intervention. If necessary the genset with the lowest number of operating hours is started, and remains operational as long as required (until the conditions that started the genset are no longer applicable). **Time** = If necessary the genset with the lowest number of operating hours is started, and remains operational until its operating hours exceed those of the alternative genset by an amount equal to or greater than those programmed with the following parameter. When this condition arises, the load is switched from one genset to the other.

P23.06 - Max. deviation on the operating hours of the gensets in mutual stand-by. See previous parameter.

P23.07 - Type of connection between RGK800 and RGKRR relay remote unit. **OFF** = Communication disabled. **OUT** = Communication through programmable output set for *Remote alarms* function, connected to the digital input of the RGKRR. **CAN** = The RGK800 and RGKRR communicate through the CAN interface. Unless there are indications to the contrary for a specific ECU, it is usually possible to communicate simultaneously with the RGKRR and the engine ECU on the same CAN line. See RGKRR manual for more details.

P23.08 - **Normal** = Standard operation in AUT mode. **EJP** = 2 programmable inputs are used, set with the functions *Remote starting* and *Remote switching* for EJP. When the starting input closes the engine start (P23.09) delay is enabled, after which the start cycle runs. Then, when the remote switching go-ahead is received, if the engine started properly, the load will be switched from the mains to the generator. The load is restored to the mains by the remote switching go-ahead opening and the genset runs a stop cycle when the start input opens. The EJP function is only enabled if the system is in automatic mode. The cutouts and alarms function as usual. **EJP-T** = The EJP/T function is a simplified variation of the previous EJP, and in this case the engine start is controlled in the same way, but a timer switches the load instead of an external signal. This function therefore uses only one digital input, the starting input. The switching delay starts from when the start command closes, and can be set using parameter P23.10 *Switching delay*.

SCR = The SCR function is very similar to the EJP function. In this mode, the starting input enables genset starting as for EJP, without waiting for delay P23.09. The remote switching input still has a switching go-ahead function after *Switching delay* P23.10.

P23.09 - Delay between the closing of the generator EJP starting signal and the beginning of the starting cycle.

P23.10 - Delay for switching the load from mains to generator in EJP and SCR mode.

P23.11 - If ON, in EJP and EJP-T mode, the load will not be switched back to the mains in the case of a generator malfunction, but only when the signals on the EJP inputs give a

ciclo di avviamento.

P23.10 – Ritardo di commutazione del carico da rete a generatore in modalità EJP e SCR.

P23.11 – Se ON, in modalità EJP e EJP-T il carico non viene ricommutato sul lato rete in caso di avaria del generatore, ma solo quando i segnali sugli ingressi EJP danno il consenso.

P23.12 - Se On, in caso di avaria del dispositivo di commutazione lato rete che ne comporti la mancata chiusura e la conseguente generazione dell'allarme *A41 Anomalia contattore rete*, il motore viene avviato e il carico commutato sul generatore.

P23.13 - Definisce in quale delle modalità operative si deve attivare l'uscita programmata con la funzione *Modo di funzionamento*. Ad esempio, se si programma questo parametro su O+M, l'uscita *Modo di funzionamento* verrà attivata quando l' RGK800 si trova in modalità OFF oppure MAN.

P23.14 - Definisce se deve essere effettuata l'analisi armonica sulle forme d'onda di tensione e corrente del generatore. **OFF** = Analisi armonica non effettuata. **THD** = Solo calcolo e visualizzazione THD (Total Harmonic Distortion). **THD+HAR** = Calcolo e visualizzazione del THD, dello spettro armonico e delle forme d'onda.

go-ahead.

P23.12 - If On, in the case of a mains switchgear malfunction which doesn't prevent closing and the consequent generation of the alarm *A41 Mains contactor anomaly*, the engine is started and the load switched to the generator.

P23.13 - Defines in which operating mode the programmed output with the *Operating mode* function is enabled. For example, if this parameter is programmed for O+M, the *Operating mode* output will be enabled when the RGK800 is in OFF or MAN mode.

P23.14 - Defines whether the harmonic analysis should be performed on the generator voltage and current waveforms. **OFF** = Harmonic analysis not performed. **THD** = THD (Total Harmonic Distortion) display and calculation only. **THD+HAR** = THD display and calculation of the harmonic spectrum and wave form.

M24 - SOGLIE LIMITE (LIMn, n = 1...16)		UdM	Default	Range
P24.n.01	Misura di riferimento		OFF	OFF- (lista misure) AINx CNTx
P24.n.02	Sorgente misura di riferimento		OFF	OFF RETE GEN
P24.n.03	Nr. Canale (x)		1	1..99
P24.n.04	Funzione		Max	Max Min Min+Max
P24.n.05	Soglia superiore		0	-9999 - +9999
P24.n.06	Moltiplicatore		x1	/100 - x10k
P24.n.07	Ritardo	s	0	0.0 - 600.0
P24.n.08	Soglia inferiore		0	-9999 - +9999
P24.n.09	Moltiplicatore		x1	/100 - x10k
P24.n.10	Ritardo	s	0	0.0 - 600.0
P24.n.11	Stato a riposo		OFF	OFF-ON
P24.n.12	Memoria		OFF	OFF-ON

Nota: questo menu è diviso in 16 sezioni, per le soglie limite LIM1..16

P24.n.01 – Definisce a quale delle misure fornite dall'RGK800 applicare la soglia limite.

P24.n.02 – Se la misura di riferimento è una misura elettrica, qui si definisce se essa è riferita alla rete o al generatore.

P24.n.03 – Se la misura di riferimento è una misura interna multicanale (esempio AINx), qui si definisce quale canale.

P24.n.04 – Definisce il modo di funzionamento della soglia limite. **Max** = LIMn attivo quando la misura supera P24.n.03. P24.n.06 è la soglia di ripristino. **Min** = LIMn attivo quando la misura è inferiore a P24.n.06. P24.n.03 è la soglia di ripristino. **Min+Max** = LIMn attivo quando la misura è superiore a P24.n.03 oppure inferiore a P24.n.06.

P24.n.05 e **P24.n.06** - Definiscono la soglia superiore, che è data dal valore di P24.n.03 moltiplicato per P24.n.04.

P24.n.07 - Ritardo di intervento sulla soglia superiore.

P24.n.08, P08.n.09, P08.n.10 - come sopra, riferiti alla soglia inferiore.

P24.n.11 - Permette di invertire lo stato del limite LIMn.

P24.n.12 - Definisce se la soglia rimane memorizzata e va azzerata manualmente tramite menu comandi (ON) o se si ripristina automaticamente (OFF).

M24 - LIMIT THRESHOLDS (LIMn, n = 1...16)		UdM	Default	Range
P24.n.01	Reference measurement		OFF	OFF- (measur. list) AINx CNTx
P24.n.02	Reference measurement source		OFF	OFF MAINS GEN
P24.n.03	Channel no. (x)		1	1..99
P24.n.04	Function		Max	Max Min Min+Max
P24.n.05	Upper threshold		0	-9999 - +9999
P24.n.06	Multiplier		x1	/100 - x10k
P24.n.07	Delay	s	0	0.0 - 600.0
P24.n.08	Lower threshold		0	-9999 - +9999
P24.n.09	Multiplier		x1	/100 - x10k
P24.n.10	Delay	s	0	0.0 - 600.0
P24.n.11	Idle state		OFF	OFF-ON
P24.n.12	Memory		OFF	OFF-ON

Nota: this menu is divided into 16 sections for the limit thresholds LIM1..16

P24.n.01 – Defines to which RGK800 measurements the limit threshold applies.

P24.n.02 – If the reference measurement is an electrical measurement, this defines if it refers to the generator.

P24.n.03 – If the reference measurement is an internal multichannel measurement (AINx for example), the channel is defined.

P24.n.04 – Defines the operating mode of the limit threshold. **Max** = LIMn enabled when the measurement exceeds P24.n.03. P24.n.06 is the reset threshold. **Min** = LIMn enabled when the measurement is less than P24.n.06. P24.n.03 is the reset threshold. **Min+Max** = LIMn enabled when the measurement is greater than P24.n.03 or less than P24.n.06.

P24.n.05 and **P24.n.06** - Define the upper threshold, obtained by multiplying value P24.n.03 by P24.n.04.

P24.n.07 - Upper threshold intervention delay.

P24.n.08, P08.n.09, P08.n.10 - As above, with reference to the lower threshold.

P24.n.11 - Inverts the state of limit LIMn.

P24.n.12 - Defines whether the threshold remains memorized and is reset manually through command menu (ON) or if it is reset automatically (OFF).

M25 - CONTATORI (CNTn, n = 1...8)		UdM	Default	Range
P25.n.01	Sorgente conteggio		OFF	OFF ON INPx OUTx LIMx REMx PLCx RALx
P25.n.02	Numero canale (x)		1	1-99
P25.n.03	Moltiplicatore		1	1-1000
P25.n.04	Divisore		1	1-1000
P25.n.05	Descrizione del contatore		CNTn	(Testo - 16 caratteri)
P25.n.06	Unità di misura		UMn	(Testo - 6 caratteri)
P25.n.07	Sorgente di reset		OFF	OFF-ON-INPx- OUTx-LIMx- REMx-PLCx- RALx
P25.n.08	Numero canale (x)		1	1-16

Nota: questo menu è diviso in 8 sezioni, per i contatori CNT1..8

P25.n.01 - Segnale che provoca l'incremento del conteggio (sul fronte di salita). Può essere la messa in tensione dell' RGK800 (ON), il superamento di una soglia (LIMx), l'attivazione di un ingresso esterno (INPx), una condizione logica (PLCx) ecc.

P25.n.02 - Numero del canale x riferito al parametro precedente.

P25.n.03 - K moltiplicativo. Gli impulsi contati vengono moltiplicati per questo valore prima di essere visualizzati.

P25.n.04 - K frazionario. Gli impulsi contati vengono divisi per questo valore prima di essere visualizzati. Se diverso da 1, il contatore viene visualizzato con 2 cifre decimali.

P25.n.05 - Descrizione del contatore. Testo libero 16 caratteri.

M25 - COUNTERS (CNTn, n = 1...8)		UdM	Default	Range
P25.n.01	Count source		OFF	OFF ON INPx OUTx LIMx REMx PLCx RALx
P25.n.02	Channel number (x)		1	1-99
P25.n.03	Multiplier		1	1-1000
P25.n.04	Divisor		1	1-1000
P25.n.05	Description of the counter		CNT n	(Text - 16 characters)
P25.n.06	Unit of measurement		UMn	(Text - 6 characters)
P25.n.07	Reset source		OFF	OFF-ON- INPx-OUTx- LIMx-REMx- PLCx-RALx
P25.n.08	Channel number (x)		1	1-16

Nota: this menu is divided into 8 sections for counters CNT1..8

P25.n.01 - Signal that increments the count (on the output side). This may be the start-up of the RGK800 (ON), when a threshold is exceeded (LIMx), an external input is enabled (INPx), or for a logic condition (PLCx), etc.

P25.n.02 - Channel number x with reference to the previous parameter.

P25.n.03 - Multiplier K. The counted pulses are multiplied by this value before being displayed.

P25.n.04 - Divisional K. The counted pulses are divided by this value before being displayed. If other than 1, the counter is displayed with 2 decimal points.

P25.n.05 - Counter description. 16-character free text.

P25.n.06 - Counter unit of measurement. 6-character free text.

P25.n.06 - Unità di misura del contatore. Testo libero 6 caratteri.
P25.n.07 - Segnale che provoca l'azzeramento del conteggio. Fino a che questo segnale è attivo il conteggio rimane al valore zero.
P25.n.08 - Numero del canale x riferito al parametro precedente.

P25.n.07 - Signal that resets the count. As long as this signal is enabled, the count remains zero.
P25.n.08 - Channel number x with reference to the previous parameter.

M26 - PAGINE UTENTE (PAGn, n = 1...4)	UdM	Default	Range
P26.n.01 Abilitazione pagina		OFF	OFF – ON
P26.n.02 Titolo		PAGn	(testo 16 char)
P26.n.03 Misura 1		OFF	OFF-(tutte le misure)
P26.n.04 Misura 2		OFF	OFF-(tutte le misure)
P26.n.05 Misura 3		OFF	OFF-(tutte le misure)

Nota: questo menu è diviso in 4 sezioni, per le pagine utente PAG1...PAG4
P26.n.01 = Abilita la pagina utente PAGn.
P26.n.02 = Titolo della pagina utente. Testo libero.
P26.n.03, P26.n.04, P26.n.05 = Misure che verranno visualizzate nei riquadri della pagina utente.

M26 - USER PAGES (PAGn, n = 1...4)	UdM	Default	Range
P26.n.01 Enable page		OFF	OFF – ON
P26.n.02 Title		PAGn	(text - 16 char)
P26.n.03 Measurement 1		OFF	OFF/ (all measures)
P26.n.04 Measurement 2		OFF	OFF/ (all measures)
P26.n.05 Measurement 3		OFF	OFF/ (all measures)

Note: this menu is divided into 4 sections for the user pages PAG1...PAG4
P26.n.01 = Enables user page PAGn.
P26.n.02 = User page title. Free text.
P26.n.03, P26.n.04, P26.n.05 = Measurements which will be displayed in the text boxes on the user page.

M27 - REMOTAZIONE ALLARMI /STATI (RALn, n = 1...24)	UdM	Default	Range
P27.n.01 Funzione uscita RALn		(varie)	(Vedi tabella funzioni uscita)
P27.n.02 Indice funzione (x)		OFF	OFF / 1...99
P27.n.03 Uscita normale / inversa		NOR	NOR / REV

Nota: questo menu è diviso in 24 sezioni, per le variabili di remozione stati/allarmi RAL1...RAL24, disponibili in abbinamento alla unità esterna RGKRR
P27.n.01 - Seleziona la funzione della uscita remota RALn. Le uscite remote (relè della unità remota RGKRR) possono assumere le stesse funzioni delle uscite locali, inclusi gli stati operativi, gli allarmi ecc.
P27.n.02 - Indice eventualmente associato alla funzione programmata al parametro precedente. Esempio: Se la funzione dell'uscita remota è impostata sulla funzione *Allarme Axx*, e si vuole far sì che questa uscita si ecciti quando si verifica l'allarme A31, allora P27.n.02 va impostato al valore 31.
P27.n.03 - Imposta lo stato della uscita quando la funzione ad essa associata non è attiva:
NOR = uscita diseccitata, **REV** = uscita eccitata.

M27 - REMOTE ALARM/STATUS (RALn, n = 1...24)	UdM	Default	Range
P27.n.01 Output function RALn		(various)	(See Output functions table)
P27.n.02 Function index (x)		OFF	OFF / 1...99
P27.n.03 Normal/reverse output		NOR	NOR / REV

Note: this menu is divided into 24 sections for the state/alarms remote variables RAL1...RAL24, available with the RGKRR external unit.
P27.n.01 - Selects the remote output function RALn. The remote outputs (relay from RGKRR remote unit) can have the same functions as local outputs, including operating states, alarms, etc.
P27.n.02 - Index associated with the function programmed in the previous parameter.
 Example: If the remote output function is set to *Alarm Axx*, and you want this output to be energized for alarm A31, then P27.n.02 should be set to value 31.
P27.n.03 - Sets the state of the output when the function associated with the same is inactive:
NOR = output de-energized, **REV** = output energized.

M28 - INGRESSO RESISTIVO PROGR.	UdM	Default	Range
P28.01 Curva sensore resistivo		OFF	OFF VDO VEGLIA DATCON CUSTOM
P28.02 Offset sensore resistivo	Ohm	0	-30.0 - +30.0
P28.03 Descrizione	AINn	(Testo - 16 caratteri)	
P28.04 Unità di misura	UMn	(Testo - 6 caratteri)	

P28.01 - Seleziona quale curva Misura/Ohm utilizzare. Le curve possono essere impostate liberamente utilizzando il software Customization manager.
P28.02 - Permette di aggiungere o togliere un offset in Ohm alla curva impostata, per compensare ad esempio la lunghezza dei cavi. Questo valore può essere anche impostato senza entrare in setup, tramite la funzione rapida nel menu comandi che consente di vedere le misure mentre si esegue la taratura.
P28.03 - Descrizione della misura associata al sensore resistivo programmabile (testo libero).
P28.04 - Unità di misura (testo libero).

M28 - PROGRAMMABLE RESISTIVE SENSOR	UdM	Default	Range
P28.01 Resistive sensor curve		OFF	OFF VDO VEGLIA DATCON CUSTOM
P28.02 Resistive sensor offset	Ohm	0	-30.0 - +30.0
P28.03 Description	AINn	(text - 16 char.)	
P28.04 Unit of measurement	UMn	(text - 16 char.)	

P28.01 - Selects which Measurement/Ohm curve to use. The curves can be custom set using the Customisation Manager software.
P28.04 - This lets you add or subtract an offset in Ohms from the set curve, to compensate for cable length for example. This value can also be set without opening setup by using the quick function in the commands menu which lets you view the measurements while calibrating.
P28.03 - Description of the measurement associated with the programmable resistive sensor (free text).
P28.04 - Unit of measurement (free text).

M29 - INGRESSI ANALOGICI (AINn, n=1...6)	UdM	Default	Range
P29.n.01 Tipo di ingresso		OFF	OFF 0...20mA 4...20mA 0...10V -5V...+5V PT100
P29.n.02 Valore inizio scala		0	-9999 - +9999
P29.n.03 Moltiplicatore		x1	/100 - x1k
P29.n.04 Valore fondo scala		0	-9999 - +9999
P29.n.05 Moltiplicatore		x1	/100 - x1k
P29.n.06 Descrizione	AINn	(Testo - 16 caratteri)	
P29.n.07 Unità di misura	UMn	(Testo - 6 caratteri)	

M29 - ANALOG INPUTS (AINn, n=1...6)	UdM	Default	Range
P29.n.01 Input type.		OFF	OFF 0...20mA 4...20mA 0...10V -5V...+5V PT100
P29.n.02 Start of scale value		0	-9999 - +9999
P29.n.03 Multiplier		x1	/100 - x1k
P29.n.04 End of scale value		0	-9999 - +9999
P29.n.05 Multiplier		x1	/100 - x1k
P29.n.06 Description	AINn		
P29.n.07 Unit of measurement	UMn		

Nota: questo menu è diviso in 6 sezioni, per gli ingressi analogici AIN1...AIN6, disponibili in abbinamento ai moduli di espansione EXP1004

P29.n.01 - Specifica il tipo di sensore collegato all'ingresso analogico. A seconda del tipo selezionato, il sensore dovrà essere collegato al morsetto opportuno. Vedere manuale modulo di ingresso.

P29.n.02 e P29.n.03 - Definiscono il valore da visualizzare quando il segnale del sensore è al minimo, cioè all'inizio del range definito dal tipo (0mA, 4mA, 0V, -5V ecc). Nota: questi parametri non vengono utilizzati quando il sensore è di tipo PT100.

P29.n.04 e P29.n.05 - Definiscono il valore da visualizzare quando il segnale del sensore è al massimo, cioè al fondoscala del range definito dal tipo (20ma, 10V, +5V ecc). Questi parametri non vengono utilizzati quando il sensore è di tipo PT100.

P29.n.06 - Descrizione della misura legata all'ingresso analogico. Testo libero 16 caratteri.

P29.n.07 - Unità di misura. Testo libero 6 caratteri. Se l'ingresso è di tipo PT100 e il testo dell'unità di misura è °F, la visualizzazione della temperatura sarà in gradi Fahrenheit, altrimenti sarà in gradi Celsius.

Esempio applicativo: L'ingresso analogico AIN3 dovrà leggere un segnale 4...20mA da un sensore di livello elettronico, che dovrà essere indicato sul display con la descrizione 'Livello serbatoio riserva', e con un fondo scala di 1500 litri.
 Programmiamo quindi la sezione 3 di questo menu, riferita a AIN3.
 P29.3.01 = 4...20mA
 P29.3.02 = 0
 P29.3.03 = x1 (0 x 1 = 0 litri, valore inizio scala corrispondente a 4mA)
 P29.3.04 = 1500 (1500 x 1 = 1500, valore fondo scala riferito a 20mA)
 P29.3.05 = x1
 P29.3.06 = 'Liv. Serbatoio riserva'
 P29.3.07 = 'litri'

Note: this menu is divided into 6 sections for the analog inputs AIN1...AIN6, available with the EXP1004 expansion modules.

P29.n.01 - Specifies the type of sensor connected to analog input. The sensor should be connected to the appropriate terminal for the type selected. See input module manual.

P29.n.02 and P29.n.03 - Define the value to display for a min. sensor signal, in other words at the start of the range defined by the type (0mA, 4mA, 0V, -5V, etc.). Note: these parameters aren't used for a type PT100 sensor.

P29.n.04 and P29.n.05 - Define the value to display for a max. sensor signal, in other words at the end of scale of the range defined by the type (20ma, 10V, +5V, etc.). These parameters aren't used for a type PT100 sensor.

P29.n.06 - Description of measurements associated with analog input. 16-character free text.

P29.n.07 - Unit of measurement. 6-character free text. If the input is type PT100 and the text of the unit of measurement is °F, the temperature will be displayed in degrees Fahrenheit, otherwise it will be in degrees Celsius.

Example of application: The analog input AIN3 must read a 4...20mA signal from an electronic level sensor, that will have to be shown on the display with the description 'Reserve fuel tank level', with a full scale of 1500 litres.
 So, we must program section 3 of this menu, that is referred to AIN3.
 P29.3.01 = 4...20mA
 P29.3.02 = 0
 P29.3.03 = x1 (0 x 1 = 0 litres, initial scale value that corresponds to 4mA)
 P29.3.04 = 1500 (1500 x 1 = 1500, full scale value that corresponds to 20mA)
 P29.3.05 = x1
 P29.3.06 = 'Reserve tank level'
 P29.3.07 = 'litres'

M30 - USCITE ANALOGICHE (AOUn, n=1...6)	UdM	Default	Range
P30.n.01 Tipo di uscita		OFF	OFF 0...20mA 4...20mA 0...10V -5V...+5V
P30.n.02 Misura di riferimento		OFF	OFF- (misure)
P30.n.03 Sorgente di riferimento		OFF	OFF RETE GEN
P30.n.04 Numero canale (x)			
P30.n.05 Valore inizio scala		0	-9999 - +9999
P30.n.06 Moltiplicatore		x1	/100 - x10k
P30.n.07 Valore fondo scala		0	-9999 - +9999
P30.n.08 Moltiplicatore		x1	/100 - x10k

Nota: questo menu è diviso in 6 sezioni, per le uscite analogiche AO1...AO6, disponibili in abbinamento ai moduli di espansione EXP1005

P30.n.01 - Specifica il tipo di segnale analogico in uscita. A seconda del tipo selezionato, il collegamento dovrà essere effettuato sul morsetto opportuno. Vedere il manuale del modulo di uscita analogica.

P30.n.02 - Misura da cui dipende il valore dell'uscita analogica.

P30.n.05 e P30.n.06 - Definiscono il valore della misura che corrisponde ad un valore in uscita al minimo del range (0mA, 4mA, 0V, -5V ecc).

P30.n.07 e P30.n.08 - Definiscono il valore della misura che corrisponde al massimo del range (20ma, 10V, +5V, ecc).

Esempio applicativo: L'uscita analogica AO2 dovrà emettere un segnale 0...20mA proporzionale alla potenza attiva totale in uscita dal generatore, da 0 a 500kW.
 Programmiamo quindi la sezione 2 di questo menu, riferita a AO2.
 P30.2.01 = 0...20mA
 P30.2.02 = kW tot
 P30.2.03 = GEN
 P30.2.04 = 1 (non utilizzato)
 P30.2.05 = 0
 P30.2.06 = x1 (0 x 1 = 0 W, valore inizio scala)
 P30.2.07 = 500
 P30.2.08 = x1k (500 x 1k = 500 kW, valore fondo scala)

M30 - ANALOG OUTPUTS (AOUn, n=1...6)	UdM	Default	Range
P30.n.01 Output type		OFF	OFF 0...20mA 4...20mA 0...10V -5V...+5V
P30.n.02 Reference measurement		OFF	OFF- (meas.)
P30.n.03 Reference source		OFF	OFF MAINS GEN
P30.n.04 Channel nr. (x)			
P30.n.05 Start of scale value		0	-9999 - +9999
P30.n.06 Multiplier		x1	/100 - x10k
P30.n.07 End of scale value		0	-9999 - +9999
P30.n.08 Multiplier		x1	/100 - x10k

Note: this menu is divided into 6 sections for the analog outputs AO1...AO6 available with EXP1005 expansion modules

P30.n.01 - Specifies the type of output analog signal. The sensor should be connected to the appropriate terminal on the basis of the type selected. See analog output module manual.

P30.n.02 - Measurement on which the analog output value depends.

P30.n.05 and P30.n.06 - Define the value of the measurement that corresponds to a min. output value in the range (0mA, 4mA, 0V, -5V, etc.).

P30.n.07 and P30.n.08 - Define the value of the measurement that corresponds to a max. value in the range (20ma, 10V, +5V, etc.).

Application example: The analog output AO2 must emit a 0...20mA signal proportional to the total active power output of the generator, from 0 to 500kW.
 So, we must program section 2 of this menu, that is referred to AO2.
 P30.2.01 = 0...20mA
 P30.2.02 = kW tot
 P30.2.03 = GEN
 P30.2.04 = 1 (not used)
 P30.2.05 = 0
 P30.2.06 = x1 (0 x 1 = 0 W, begin of scale value)
 P30.2.07 = 500
 P30.2.08 = x1k (500 x 1k = 500 kW, full scale value)

M31 - IMPULSI ENERGIA (PULn, n=1...6)	UdM	Default	Range
P31.n.01 Sorgente impulso		OFF	OFF kWh M kWh G kvarh M kvarh G kVA M kVA G
P31.n.02 Unità di conteggio		100	10/100/1k/10k
P31.n.03 Durata impulso	s	0.1	0.1-1.00

Nota: questo menu è diviso in 6 sezioni, per la generazione delle variabili impulso sul consumo energia PUL1...PUL6.

P31.n.01 - Definisce da quale contatore di energia deve essere generato l'impulso, fra i 6 possibili contatori gestiti dall'RGK800. kWh M = energia attiva rete. kWh G = energia attiva generatore. kvarh M = Energia reattiva rete. kvarh G = Energia reattiva generatore. kVA M = energia apparente rete. kVA G = energia apparente generatore.

P31.n.02 - Quantità di energia che deve accumularsi per l'emissione di un impulso (esempio 10Wh, 100Wh, 1kWh ecc.).

P31.n.03 - Durata dell'impulso.

M31 - ENERGY PULSES (PULn, n=1...6)	UdM	Default	Range
P31.n.01 Pulse source		OFF	OFF kWh M kWh G kvarh M kvarh G kVA M kVA G
P31.n.02 Counting unit		100	10/100/1k/10k
P31.n.03 Pulse duration	s	0.1	0.1-1.00

Note: this menu is divided into 6 sections, for the generation of energy consumption pulse variables PUL1...PUL6.

P31.n.01 - Defines which energy meter should generate the pulse of the 6 possible meters managed by the RGK800. kWh M = Mains active energy. kWh G = Generator active energy. kvarh M = Mains reactive energy. kvarh G = Generator reactive energy. kVA M = Mains apparent energy. kVA G = Generator apparent energy.

P31.n.02 - The quantity of energy which must accumulate for a pulse to be emitted (for example 10Wh, 100Wh, 1kWh, etc.).

P31.n.03 - Pulse duration.

*Esempio applicativo: Ad ogni 0,1 kWh in uscita dal generatore, dovrà essere generato un impulso della durata di 500ms sulla uscita OUT10.
Innanzitutto bisogna creare una variabile interna impulso, ad esempio PUL1. Quindi programiamo la sezione 1 di questo menu come segue:
P31.1.01 = kWh G (energia attiva generatore)
P31.1.02 = 100Wh (corrispondenti a 0,1 kWh)
P31.1.03 = 0,5
A questo punto bisognerà impostare l'uscita OUT10 legandola alla variabile impulso PUL1:
P19.10.01 = PULx
P19.10.02 = 1 (PUL1)
P19.10.03 = NOR*

*Application example: For every 0,1 kWh output by generator, a pulse of 100ms has to be generated on output OUT10.
First of all we should generate an internal pulse variable, for instance PUL1. So we must program section 1 of this menu as follows:
P31.1.01 = kWh G (generator active energy)
P31.1.02 = 100Wh (correspond to 0,1 kWh)
P31.1.03 = 0,5
Now we must set output OUT10 and link it to PUL1:
P19.10.01 = PULx
P19.10.02 = 1 (PUL1)
P19.10.03 = NOR*

M32 - ALLARMI UTENTE (UAn, n=1...8)	UdM	Default	Range
P32.n.01 Sorgente allarme		OFF	OFF INPx OUTx LIMx REMX PLCx RALx
P32.n.02 Numero canale (x)		1	1-8
P32.n.03 Testo		UAn	(testo – 20 char)

Nota: questo menu è diviso in 8 sezioni, per la definizione degli allarmi utente UA1...UA8.
P32.n.01 - Definizione dell' ingresso digitale o variabile interna la cui attivazione genera l'allarme utente.
P32.n.02 - Numero di canale riferito al parametro precedente.
P32.n.03 - Testo libero che comparirà nella finestra di allarme.

*Esempio applicativo: L'allarme utente UA3 deve essere generato dalla chiusura dell'ingresso INP5, e deve mostrare il messaggio 'Sportelli aperti'.
In questo caso impostare la sezione di menu 3 (per l'allarme UA3):
P32.3.01 = INPx
P32.3.02 = 5
P32.3.03 = 'Sportelli aperti'*

M32 - USER ALARMS (UAn, n=1...8)	UdM	Default	Range
P32.n.01 Alarm source		OFF	OFF INPx OUTx LIMx REMX PLCx RALx
P32.n.02 Channel number (x)		1	1-8
P32.n.03 Text		UAn	(text – 20 char)

Note: this menu is divided into 8 sections for user alarms UA1...UA8
P32.n.01 - Defines the digital input or internal variable that generates the user alarm when it is activated.
P32.n.02 - Channel number x with reference to the previous parameter.
P32.n.03 - Free text that appears in the alarm window.

*Example of application: User alarm UA3 must be generated by the closing of input INP5, and must display the message 'Panels open'.
In this case, set the section of menu 3 (for alarm UA3):
P32.3.01 = INPx
P32.3.02 = 5
P32.3.03 = 'Panels open'*

Allarmi

- Al sorgere di un allarme, il display mostra una icona di allarme, un codice identificativo e la descrizione dell'allarme nella lingua selezionata.



- Se vengono premuti dei tasti di navigazione delle pagine, la finestra pop-up con le indicazioni di allarme scompare momentaneamente per poi ricomparire dopo alcuni secondi.
- Fintanto che un allarme è attivo il LED rosso vicino all'icona di allarme sul frontale lampeggia.
- Se abilitati, gli allarmi acustici locali e remoti vengono attivati.
- Il reset degli allarmi si può effettuare in uno dei seguenti modi:
 - premendo il tasto ✓
 - premendo il tasto OFF
- Passando in modalità operativa OFF si prevengono avviamenti indesiderati del motore a seguito del reset dell'allarme stesso.
- Se l'allarme non si resetta, significa che persiste la causa che lo ha provocato.
- In seguito al verificarsi di uno o più allarmi, l'RGK800 ha un comportamento dipendente dalla impostazione delle *proprietà* degli allarmi attivi.

Alarms

- When an alarm is generated, the display will show an alarm icon, the code and the description of the alarm in the language selected.

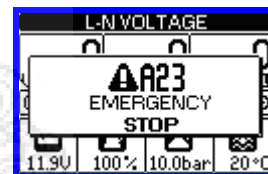

- If the navigation keys in the pages are pressed, the pop-up window showing the alarm indications will disappear momentarily, to reappear again after a few seconds.
- The red LED near the alarm icon on the front panel will flash when an alarm is active.
- If enabled, the local and remote alarm buzzers will be activated.
- Alarms can be reset in one of the following ways:
 - by pressing the key ✓
 - by pressing the OFF key.
- Switching OFF prevents unexpected engine starting after resetting the alarm.
- If the alarm cannot be reset, the problem that generated the alarm must still be solved.
- In the case of one or more alarms, the behaviour of the RGK800 depends on the *properties* settings of the active alarms.

Proprietà degli allarmi

Ad ogni allarme, compresi gli allarmi utente (*User Alarms*, UAx) possono essere assegnate diverse proprietà:

- **Allarme abilitato** - Abilitazione generale dell'allarme. Se non abilitato è come se non esistesse.
- **Allarme ritenitivo** - Rimane memorizzato anche se è stata rimossa la causa che lo ha provocato.
- **Allarme globale** - Attiva l'uscita assegnata a questa funzione.
- **Avaria meccanica** - Attiva l'uscita assegnata a questa funzione.
- **Avaria elettrica** - Attiva l'uscita assegnata a questa funzione.
- **Sirena** - Attiva l'uscita assegnata a questa funzione, con le modalità definite nel menu Allarmi acustici.
- **Arresto motore** - Provoca l'arresto del motore.
- **Raffreddamento motore** - Provoca l'arresto del motore con ciclo di raffreddamento secondo le modalità programmate (durata, condizioni).
- **Attivo con motore avviato** - L'allarme viene generato solo quando il motore è in moto ed è trascorso il tempo di inserimento allarmi.
- **Inibizione** - L'allarme può essere disabilitato temporaneamente tramite l'attivazione di un ingresso programmabile con la funzione Inibizione allarmi.
- **Modem** - Viene effettuato un collegamento modem con le modalità previste dai relativi dati di set-up impostati.
- **No LCD** - L'allarme viene gestito normalmente ma non viene visualizzato sul display.

Tabella allarmi

COD	DESCRIZIONE	PROPRIETA' ALLARMI DI DEFAULT											
		Abilitato	Ritenitivo	All. Glob.	Av. Mec.	Av. Elett.	Sirena	Stop mot.	Raffredd.	Mot. Avv.	Inibiz.	Modem	No LCD
A01	Preallarme temperatura motore (sensore analogico)			•			•			•		•	
A02	Alta temperatura motore (sensore analogico)		•	•	•		•	•		•		•	
A03	Guasto sensore analogico temperatura		•	•	•		•			•		•	
A04	Alta temperatura motore (sensore digitale)	•	•	•	•		•			•		•	
A05	Bassa temperatura motore (sensore analogico)			•			•					•	
A06	Preallarme pressione olio (sensore analogico)			•			•			•		•	
A07	Bassa pressione olio (sensore analogico)		•	•	•		•	•		•		•	
A08	Guasto sensore analogico pressione		•	•	•		•			•		•	
A09	Bassa pressione olio (sensore digitale)	•	•	•	•		•	•		•		•	
A10	Guasto sensore digitale pressione	•	•	•	•		•			•		•	
A11	Preallarme livello carburante (sensore analogico)			•			•					•	
A12	Basso livello carburante (sensore analogico)			•			•					•	
A13	Guasto sensore analogico livello		•	•	•		•					•	
A14	Basso livello carburante (sensore digitale)	•		•			•					•	
A15	Tensione batteria alta	•	•	•	•		•					•	
A16	Tensione batteria bassa	•	•	•	•		•					•	
A17	Batteria inefficiente	•	•	•	•		•					•	
A18	Avaria alternatore carica batteria	•	•	•	•		•	•		•		•	
A19	Avaria segnale "W / pick-up"		•	•	•		•			•		•	
A20	Bassa velocità motore "W / pick-up"		•	•	•		•			•		•	
A21	Alta velocità motore "W / pick-up"		•	•	•		•	•		•		•	
A22	Mancato avviamento	•	•	•	•		•	•				•	
A23	Arresto di emergenza	•	•	•	•		•	•		•		•	
A24	Arresto inaspettato	•	•	•	•		•	•		•		•	
A25	Mancato arresto	•	•	•	•		•	•				•	

Alarm properties

Various properties can be assigned to each alarm, including user alarms (*User Alarms*, UAx):

- **Alarm enabled** - General enabling of the alarm. If the alarm isn't enabled, it's as if it doesn't exist.
- **Retained alarm** - Remains in the memory even if the cause of the alarm has been eliminated.
- **Global alarm** - Activates the output assigned to this function.
- **Mechanical fault** - Activates the output assigned to this function.
- **Electrical fault** - Activates the output assigned to this function.
- **Siren** - Activates the output assigned to this function, as configured in the acoustic Alarms menu.
- **Engine stop** - Stops the engine.
- **Engine cooling** - Stops the engine after a cooling cycle, depending on the cooling mode programming (duration and conditions).
- **Active with engine running** - The alarm is only generated when the engine is running and the alarms activation time has elapsed.
- **Inhibition** - The alarm can be temporarily disabled by activating an input that can be programmed with the Inhibit alarms function.
- **Modem** - A modem is connected as configured in setup.
- **No LCD** - The alarm is managed normally, but not shown on the display.

Alarm table

COD	DESCRIPTION	DEFAULT ALARM PROPERTIES											
		Enabled	Retained	Glob. Al.	Fault	Fault	Siren	Engine	Cooling	Motor	Inhibit.	Modem	No LCD
A01	Engine temperature warning (analog sensor)			•			•			•		•	
A02	High engine temperature (analog sensor)		•	•	•		•	•		•		•	
A03	Analog temperature sensor fault		•	•	•		•			•		•	
A04	High engine temperature (digital sensor)	•	•	•	•		•	•		•		•	
A05	Low engine temperature (analog sensor)			•			•					•	
A06	Oil pressure prealarm (analog sensor)			•			•			•		•	
A07	Low oil pressure (analog sensor)		•	•	•		•	•		•		•	
A08	Analog pressure sensor fault		•	•	•		•			•		•	
A09	Low oil pressure (digital sensor)	•	•	•	•		•	•		•		•	
A10	Digital pressure sensor fault	•	•	•	•		•			•		•	
A11	Fuel level prealarm (analog sensor)			•			•					•	
A12	Fuel level low (analog sensor)			•			•			•		•	
A13	Analog level sensor fault		•	•	•		•					•	
A14	Fuel level low (digital sensor)	•		•			•					•	
A15	High battery voltage.	•	•	•	•		•					•	
A16	Low battery voltage	•	•	•	•		•					•	
A17	Inefficient battery	•	•	•	•		•					•	
A18	Battery alternator fault	•	•	•	•		•	•		•		•	
A19	"Pick-up/W" signal fault		•	•	•		•			•		•	
A20	"Pick-up/W" engine speed low		•	•	•		•			•		•	
A21	"Pick-up/W" engine speed high		•	•	•		•	•		•		•	
A22	Starting failed	•	•	•	•		•	•				•	
A23	Emergency stopping	•	•	•	•		•	•		•		•	
A24	Unexpected stop	•	•	•	•		•	•		•		•	
A25	Engine stopping failure	•	•	•	•		•	•				•	

Descrizione degli allarmi

COD	DESCRIZIONE	MOTIVAZIONE ALLARME
A01	Preallarme temperatura motore (sensore analogico)	Temperatura motore superiore alla soglia di preallarme impostata con P09.06.
A02	Alta temperatura motore (sensore analogico)	Temperatura motore superiore alla soglia di allarme impostata con P09.07.
A03	Guasto sensore analogico temperatura	Il sensore resistivo di temperatura risulta con circuito aperto (scollegato). Se la misura proviene dal CAN, l'allarme viene generato da un apposito messaggio diagnostico.
A04	Alta temperatura motore (sensore digitale)	Sovratemperatura del motore segnalata dall'attivazione dell'ingresso digitale programmato con apposita funzione.
A05	Bassa temperatura motore (sensore analogico)	Temperatura motore inferiore alla soglia di allarme impostata con P09.08.
A06	Preallarme pressione olio (sensore analogico)	Pressione olio motore inferiore alla soglia di preallarme impostata con P08.06.
A07	Bassa pressione olio (sensore analogico)	Pressione olio motore inferiore alla soglia di allarme impostata con P08.07.
A08	Guasto sensore analogico pressione	Il sensore resistivo di pressione risulta con circuito aperto (scollegato). Se la misura proviene dal CAN, l'allarme viene generato da un apposito messaggio diagnostico.
A09	Bassa pressione olio (sensore digitale)	Bassa pressione olio segnalata dall'attivazione dell'ingresso digitale programmato con apposita funzione.
A10	Guasto sensore digitale pressione	Con motore fermo da oltre un minuto, il sensore olio non è chiuso a segnalare mancanza di pressione. Si presuppone quindi una interruzione del collegamento.
A11	Preallarme livello carburante (sensore analogico)	Livello carburante inferiore alla soglia di preallarme impostata con P10.07.
A12	Basso livello carburante (sensore analogico)	Livello carburante inferiore alla soglia allarme impostata con P10.08.
A13	Guasto sensore analogico livello	Il sensore resistivo di livello carburante risulta con circuito aperto (scollegato).
A14	Basso livello carburante (sensore digitale)	Basso livello del carburante segnalato dall'attivazione dell'ingresso digitale programmato con apposita funzione.
A15	Tensione batteria alta	Tensione di batteria più elevata della soglia impostata con P05.02 per un tempo superiore a P05.04.
A16	Tensione batteria bassa	Tensione di batteria più bassa della soglia impostata con P05.03 per un tempo superiore a P05.04.
A17	Batteria inefficiente	Tentativi di avviamento esauriti con abbassamento della tensione di batteria sotto la soglia minima di alimentazione
A18	Avaria alternatore carica batteria	Si verifica quando viene rilevato il motore in moto (presenza tensione e/o frequenza del generatore o 'W / pick-UP') ma il segnale di alternatore carica-batteria (D+) rimane sotto la soglia di tensione motore avviato P11.01 per più di 4 secondi.
A19	Avaria segnale "W / pick-up"	Con misura di velocità abilitata, l'allarme si verifica quando viene rilevato il motore in moto (presenza segnale alternatore carica batteria o tensione e/o frequenza del generatore) ma il segnale di velocità "W / pick-up" non viene rilevato entro 5 secondi. Se la misura proviene dal CAN, l'allarme viene generato da un apposito messaggio diagnostico.
A20	Bassa velocità motore "W / pick-up"	Si verifica quando viene rilevato il motore in moto (presenza segnale alternatore carica batteria o tensione e/o frequenza del generatore), non decelerato, e il segnale di velocità "W / pick-up" rimane sotto la soglia di P07.05 per il tempo impostato in P07.06.
A21	Alta velocità motore "W / pick-up"	Si verifica quando il segnale di velocità "W / pick-up" rimane sopra la soglia di P07.03 per il tempo impostato in P07.04.
A22	Mancato avviamento	Si verifica quando, dopo avere effettuato il numero di tentativi di avviamento impostati, il motore non è partito.
A23	Arresto di emergenza	Allarme generato quando viene tolta alimentazione al morsetto +COM1 (con P23.03 abilitato) oppure dalla apertura di un ingresso digitale programmato con la funzione 'Arresto di emergenza'.
A24	Arresto inaspettato	Questo allarme si manifesta quando il motore si arresta autonomamente, dopo il tempo inserimento allarmi, senza che l'apparecchio ne abbia provocato intenzionalmente lo spegnimento.
A25	Mancato arresto	Allarme generato se il motore non si è ancora fermato dopo 65 secondi dall'inizio della fase di arresto.

Alarm description

COD	DESCRIPTION	ALARM EXPLANATION
A01	Engine temperature prealarm (analog sensor)	Engine temperature higher than prealarm threshold set in P09.06.
A02	High engine temperature (analog sensor)	Engine temperature higher than alarm threshold set in P09.07.
A03	Analog temperature sensor fault	Open circuit (disconnected) resistive temperature sensor. If the measurement has been sent by the CAN, the alarm is generated by a specific diagnostics message.
A04	High engine temperature (digital sensor)	Engine overtemperature signal on activation of digital input programmed with relevant function.
A05	Low engine temperature (analog sensor)	Engine temperature lower than alarm threshold set in P09.08.
A06	Oil pressure prealarm (analog sensor)	Engine oil pressure lower than prealarm threshold set in P08.06.
A07	Low oil pressure (analog sensor)	Engine oil pressure lower than alarm threshold set in P08.07.
A08	Analog pressure sensor fault	Open circuit (disconnected) resistive pressure sensor. If the measurement has been sent by the CAN, the alarm is generated by a specific diagnostics message.
A09	Low oil pressure (digital sensor)	Low oil pressure signal on activation of digital input programmed with relevant function.
A10	Digital pressure sensor fault	Engine stopped for over one minute, but oil sensor failed to close on no pressure signal. Presumed break in connection.
A11	Fuel level prealarm (analog sensor)	Fuel level lower than prealarm threshold set in P10.07.
A12	Fuel level low (analog sensor)	Fuel level lower than alarm threshold set in P10.08.
A13	Analog level sensor fault	Open circuit (disconnected) resistive fuel level sensor.
A14	Fuel level low (digital sensor)	Low fuel level signal on activation of digital input programmed with relevant function.
A15	High battery voltage.	Battery voltage higher than threshold set in P05.02 for time greater than P05.04.
A16	Low battery voltage	Battery voltage lower than threshold set in P05.03 for time greater than P05.04.
A17	Inefficient battery	Starting attempts expired with battery voltage below min. starting threshold.
A18	Battery alternator fault	This alarm is generated when the engine is running (voltage and/or frequency from generator or 'Pick-up/W') but the battery-charger alternator signal (D+) remains below engine running voltage threshold P11.01 for more than 4 seconds.
A19	"Pick-up/W" signal fault	With speed measurement enabled, This alarm is generated when the engine is running (battery charger alternator signal present or voltage and/or frequency from generator) but the 'Pick-up/W' speed signal hasn't been detected within 5 seconds. If the measurement has been sent by the CAN, the alarm is generated by a specific diagnostics message.
A20	"Pick-up/W" engine speed low	This alarm is generated when the engine is running (battery charger alternator signal present or voltage and/or frequency from generator) but the 'Pick-up/W' speed signal remains below threshold P07.05 for longer than the time set in P07.06.
A21	"Pick-up/W" engine speed high	This alarm is generated when the 'Pick-up/W' speed signal remains below threshold P07.03 for longer than the time set in P07.04.
A22	Starting failed	This alarm is generated after the set number of starting attempts if the engine hasn't started.
A23	Emergency stopping	This alarm is generated when terminal +COM1 is disconnected (with P23.03 enabled) or by the opening of a digital input programmed with the 'Emergency stop' function'.
A24	Unexpected stop	This alarm is generated when the engine stops on its own after the alarms activation time if it wasn't stopped by the system.
A25	No stop	Alarm generated if the engine still hasn't stopped 65 seconds after the stop phase began.

A26	Bassa frequenza generatore	Allarme generato quando, con motore in moto, la frequenza del generatore è inferiore a P14.11 per il tempo impostato con P14.12.
A27	Alta frequenza generatore	Allarme generato quando la frequenza del generatore è superiore a P14.09 per il tempo impostato con P14.10.
A28	Bassa tensione generatore	Allarme generato quando, con motore in moto, la tensione del generatore è inferiore a P14.01 per il tempo impostato con P14.14.
A29	Alta tensione generatore	Allarme generato quando la tensione del generatore è superiore a P14.03 per il tempo impostato con P14.15.
A30	Asimmetria tensioni generatore	Allarme generato quando lo sbilanciamento fra le tensioni del generatore supera P14.07 per il tempo impostato da P14.08.
A31	Massima corrente generatore	La corrente del generatore supera la soglia percentuale impostata con P15.01 per il tempo di ritardo impostato con P15.02. Quando questo allarme si manifesta, prima di poterlo resettare si deve attendere il tempo di ripristino impostato con P15.05.
A32	Corto circuito generatore	La corrente del generatore supera la soglia percentuale impostata con P15.03 per il tempo di ritardo impostato con P15.04.
A33	Sovraccarico generatore	Intervento della protezione termica elettronica calcolata in base alla corrente percentuale e alla curva di protezione selezionata. Quando questo allarme si manifesta, prima di poterlo resettare si deve attendere il tempo di ripristino impostato con P15.07.
A34	Intervento protezione esterna generatore	Se programmato, si manifesta alla chiusura del contatto sull'ingresso digitale di protezione termica del generatore quando il gruppo elettrogeno è in moto.
A35	Superamento soglia kW generatore	La potenza attiva del generatore supera la soglia percentuale impostata con P22.18 per il tempo di ritardo impostato con P22.19.
A36	Guasto a terra generatore	La corrente verso terra del generatore ha superato la soglia impostata in valore assoluto con P15.08 per il tempo di ritardo impostato con P15.09.
A37	Errata sequenza fasi generatore	La sequenza fasi del generatore non corrisponde a quella programmata.
A38	Errata sequenza fasi rete	La sequenza fasi della rete non corrisponde a quella programmata.
A39	Errata impostazione frequenza di sistema	Allarme generato quando la frequenza del sistema non corrisponde alla frequenza nominale impostata.
A40	Anomalia contattore generatore	Allarme generato se dopo il tempo impostato viene rilevata una discordanza tra lo stato dell'uscita di comando e l'ingresso di feedback del contattore / interruttore generatore.
A41	Anomalia contattore rete	Allarme generato se dopo il tempo impostato viene rilevata una discordanza tra lo stato dell'uscita di comando e l'ingresso di feedback del contattore / interruttore rete.
A42	Richiesta manutenzione 1	Allarme generato quando le ore di manutenzione del relativo intervallo giungono a zero. Vedere menu M17. Utilizzare il menu comandi per ripristinare il funzionamento e azzerare l'allarme.
A43	Richiesta manutenzione 2	
A44	Richiesta manutenzione 3	
A45	Errore di sistema	Si è verificato un errore interno all'RGK800. Vedere capitolo <i>Errori di sistema</i> per possibili rimedi.
A46	Serbatoio troppo vuoto	Il relativo ingresso programmabile segnala serbatoio troppo vuoto (default attivo aperto). La pompa di rabbocco viene arrestata.
A47	Serbatoio troppo pieno	Il relativo ingresso programmabile segnala serbatoio troppo pieno (default attivo chiuso). La pompa di rabbocco viene arrestata.
A48	Ore di noleggio esaurite	Allarme generato quando le ore di noleggio giungono a zero. Utilizzare il menu comandi per ripristinare il funzionamento le ore di noleggio e azzerare l'allarme.
A49	Basso livello liquido radiatore	Allarme generato quando il livello del liquido di raffreddamento è inferiore al livello minimo. Attivato da ingresso digitale oppure da messaggio diagnostico CAN.
A50	Interruttore manuale chiuso	Allarme generato in modalità MAN ed in fase di avviamento, se viene rilevato non attivo lo stato dell'ingresso programmato con la funzione <i>Allarme stato interruttore</i> .
A51	Interruttore manuale aperto	Allarme generato in modalità AUT e durante la fase di avviamento e motore in moto, se viene rilevato attivo lo stato dell'ingresso programmato con la funzione <i>Allarme stato interruttore</i> .
A52	Allarme da carica batteria	Allarme generato dall'ingresso programmato con la funzione <i>Allarme carica batteria</i> connesso ad

A26	Low generator frequency	This alarm is generated when the engine is running but the generator frequency is lower than P14.11 for the time set in P14.12.
A27	High generator frequency	This alarm is generated when the generator frequency is higher than P14.09 for the time set in P14.10.
A28	Low generator voltage	This alarm is generated when the engine is running but the generator voltage is lower than P14.01 for the time set in P14.14.
A29	High generator voltage	This alarm is generated when the generator voltage is higher than P14.13 for the time set in P14.15.
A30	Generator voltages asymmetry	Alarm generated when the imbalance between the generator voltages exceeds P14.07 for the time set in P14.08.
A31	Max. generator current	The generator current exceeds the percentage threshold set in P15.01 for the delay set in P15.02. When this alarm is generated, you must wait for the time set in P15.05 before resetting it.
A32	Generator short-circuit	The generator current exceeds the percentage threshold set in P15.03 for the delay set in P15.04.
A33	Generator overload	Electronic cutout tripped because of percentage current and protection curve selected. When this alarm is generated, you must wait for the time set in P15.07 before resetting it.
A34	Generator external protection intervention	If programmed, this alarm is generated when the contact of the digital input of the generator thermal cutout closes, if the genset is running.
A35	Generator kW threshold exceeded	The generator active power exceeds the percentage threshold set in P22.18 for the delay set in P22.19.
A36	Generator earth fault	The earth leakage current of the generator has exceeded the threshold set as an absolute value in P15.08 for the delay set in P15.09.
A37	Generator phase sequence error	The generator phase sequence doesn't correspond to the programmed sequence.
A38	Mains phase sequence error	The mains phase sequence doesn't correspond to the programmed sequence.
A39	System frequency settings error	Alarm generated when the system frequency doesn't correspond to the set rated frequency.
A40	Generator contactor anomaly	Alarm generated if a discrepancy is detected after the set time between the state of the command output and the generator contactor/circuit breaker feedback input.
A41	Mains contactor anomaly	Alarm generated if a discrepancy is detected after the set time between the state of the command output and the mains contactor/circuit breaker feedback input.
A42	Maintenance request 1	Alarm generated when the maintenance hours of the relevant interval reach zero. See menu M17. Use the commands menu to reset the operating hours and the alarm.
A43	Maintenance request 2	
A44	Maintenance request 3	
A45	System error	RGK800 internal error. See <i>System errors</i> chapter for possible solutions.
A46	Tank too empty	The relevant programmable input signals tank too empty (active open default). Filling pump stopped.
A47	Tank too full	The relevant programmable input signals 'tank too full' (active closed default). Filling pump stopped.
A48	Rent hours expired	Alarm generated when the rent hours reach zero. Use the commands menu to reset the rent hours and the alarm.
A49	Radiator coolant level low	Alarm generated when the coolant level is lower than the min. level. Generated by digital input or CAN diagnostics message.
A50	Manual circuit breaker closed	Alarm generated in MAN mode during the starting phase, when the disabled state of the input programmed with the function <i>Circuit breaker state alarm</i> is detected.
A51	Manual circuit breaker open	Alarm generated in AUT mode during the starting phase, with the engine running, when the enabled state of the input programmed with the function <i>Circuit breaker state alarm</i> is detected.
A52	Battery charger alarm	Alarm generated by the input programmed with the function <i>Battery charger alarm</i>

		un caricabatteria esterno quando la tensione di rete è nei limiti.
A53	Allarme lampada rossa da CANbus	Allarme globale generato sul CAN bus dalla ECU motore in concomitanza di anomalie critiche.
A54	Allarme lampada gialla da CANbus	Allarme globale generato sul CAN bus dalla ECU motore in concomitanza di preallarmi o anomalie lievi.
A55	Errore da CANbus	Problema di comunicazione sul CAN bus. Controllare schemi di collegamento e stato dei cavi di connessione.
A56	Furto carburante	Il contenuto del serbatoio è sceso con una velocità media troppo elevata rispetto a quella max nominale del motore. L'allarme può anche essere generato dalla attivazione di un ingresso digitale programmato con la funzione <i>Furto carburante</i> .
A57	Cambio configurazione non possibile	E' stata cambiata la posizione degli ingressi digitali per la selezione delle 4 configurazioni possibili, ma non esistono le condizioni per attuare il cambiamento (esempio motore in moto oppure modalità operativa diversa da OFF).
A58	Acqua nel carburante	Allarme generato quando il contatto segnala presenza di acqua nel carburante. Attivato da ingresso digitale oppure da messaggio diagnostico CAN.
UA1 ... UA8	Allarme Utente	L'allarme utente è stato generato dalla attivazione della variabile o dell'ingresso associato tramite il menu M32.

Tabella funzioni ingressi

- La tabella seguente riporta tutte le funzioni che possono essere associate agli ingressi digitali programmabili INPn.
- Ciascun ingresso può essere poi impostato in modo da avere funzione invertita (NA - NC), essere ritardato alla eccitazione oppure alla diseccitazione con tempi impostabili indipendenti.
- Alcuni funzioni necessitano di un ulteriore parametro numerico, definito con l'indice (x) specificato dal parametro **P18.n.02**.
- Vedere menu *M18 Ingressi programmabili* per maggiori dettagli.

Funzione	Descrizione
Disabilitato	Ingresso disabilitato
Configurabile	Libera configurazione utente. Da usarsi ad esempio se l'ingresso viene utilizzato in una logica PLC.
Pressione olio	Sensore digitale bassa pressione olio motore.
Temperatura motore	Sensore digitale massima temperatura motore.
Livello carburante	Sensore digitale basso livello del carburante.
Arresto d'emergenza	Quando aperto genera allarme A23. Non necessario se viene utilizzato il comune +COM1 con ingresso incorporato.
Arresto a distanza	In modo AUT esegue lo stop del motore a distanza.
Start remoto off load	In modo AUT esegue lo start del motore a distanza senza commutare carico sul generatore. Il segnale deve essere mantenuto finché si desidera avere il motore acceso. Togliendo il segnale il motore inizia il ciclo di arresto.
Start remoto on load	In modo AUT esegue lo start del motore a distanza commutando il carico sul generatore. Il segnale deve essere mantenuto finché si desidera avere il motore acceso. Togliendo il segnale il motore inizia il ciclo di arresto.
Avviamento senza stop	Esegue start del motore a distanza senza arresto del motore in caso di allarme. Il segnale deve essere mantenuto finché si desidera avere il motore acceso. Togliendo il segnale il motore inizia il ciclo di arresto.
Test automatico	Avvia il test periodico gestito da un timer esterno.
Protezione generatore	Segnale di intervento protezione generatore proveniente da dispositivo esterno.
Blocco controllo remoto	Blocca le operazioni di comando e scrittura tramite porta seriale. La lettura dei dati è sempre possibile.
Blocco set-up	Inibisce l'accesso al menu programmazione.
Controllo MAINS esterno	Segnale di controllo tensione rete proveniente da apparecchio esterno. Attivato indica tensione nei limiti. Non disponibile su RGK800SA.
Controllo GEN esterno	Segnale di controllo tensione generatore proveniente da apparecchio esterno. Attivato indica tensione nei limiti.
Abilitazione presa carico su rete	Consenso alla connessione carico sulla rete. Non disponibile su RGK800SA.
Abilitazione presa carico su generatore	Consenso alla connessione carico sul generatore.
Telecommutazione	In modalità AUT, con motore in moto da start remoto, quando attivato esegue la commutazione da rete e generatore. Non disponibile su RGK800SA.
Inibizione ritorno automatico su rete	Inibisce ricommutazione automatica su rete quando questa rientra nei limiti. Non disponibile su RGK800SA.
Feed-back contattore RETE	Contatto ausiliario del dispositivo di commutazione rete, usato per informare l'RGK del suo stato effettivo (feedback).

		connected to an external battery charger when the mains voltage is within the limits.
A53	CANbus red lamp alarm	Global alarm generated on the CAN bus by the engine ECU for critical anomalies.
A54	CANbus yellow lamp alarm	Global alarm generated on the CAN bus by the engine ECU for prealarms or minor anomalies.
A55	CANbus error	CAN bus communication error. Check wiring diagrams and connecting cables.
A56	Fuel theft	The tank level has dropped at too high an average rate compared to the max. nominal engine fuel consumption. Suspected theft of fuel.
A57	Cannot change configuration	The position of the digital inputs for selecting the 4 possible configurations has changed, but there are no conditions that warrant said change (for example: engine running or operating mode other than OFF).
A58	Water in fuel	Alarm generated when the contact signals 'water in fuel'. Generated by digital input or CAN diagnostics message.
UA1 ... UA8	User alarm	The user alarm is generated by enabling the variable or associated input in menu M32.

Input function table

- The following table shows all the functions that can be attributed to the INPn programmable digital inputs.
- Each input can be set for an reverse function (NA - NC), delayed energizing or de-energizing at independently set times.
- Some functions require another numeric parameter, defined in the index (x) specified by parameter **P18.n.02**.
- See menu *M18 Programmable inputs* for more details.

Function	Description
Disabled	Disabled input
Configurable	User configuration free To use for example if the input is used in PLC logic.
Oil pressure	Engine oil pressure low digital sensor
Engine temperature	Engine max. temperature digital sensor
Fuel level	Fuel level low digital sensor
Emergency stop	Generates alarm A23 when open. Not required if common +COM1 with built-in input is used.
Remote stop	Stops the engine remotely in AUT mode.
Off load remote start	Starts the engine remotely without switching the load to the generator in AUT mode. The signal must be maintained for the time you want the engine to run. The engine begins the stop cycle when the signal is disabled.
On load remote start	Starts the engine remotely, switching the load to the generator in AUT mode. The signal must be maintained for the time you want the engine to run. The engine begins the stop cycle when the signal is disabled.
Starting without stop	Starts the engine remotely without the stop function in the case of an alarm. The signal must be maintained for the time you want the engine to run. The engine begins the stop cycle when the signal is disabled.
Automatic test	Starts the periodic test managed by an external timer.
Generator cutout	Generator cutout intervention signal from external device.
Remote control lock	Inhibits the serial port writing and command operations. The data can still be read.
Setup access lock	Inhibits access to the programming menu.
External MAINS control	Mains voltage control signal from external device. Enabled indicates the voltage is within the limits. Not available on RGK800SA.
External GEN control	Generator voltage control signal from external device. Enabled indicates the voltage is within the limits.
Enable mains load increase	Go-ahead for connection of load to mains. Not available on RGK800SA.
Enable generator load increase	Go-ahead for connection of load to generator.
Remote switching	In AUT mode, when enabled this switches from mains to generator. Not available on RGK800SA.
Inhibit automatic return to mains.	Inhibits automatic reswitching to the mains when its values are within the limits. Not available on RGK800SA.
MAINS contactor feedback.	Auxiliary contact of mains switchgear used to inform RGK of its actual state (feedback). An alarm A41 is

	In caso di discordanza fra uscita di comando e stato viene generato allarme A41. Non disponibile su RGK800SA.
Feed-back contattore GEN	Come precedente, riferito al dispositivo di commutazione generatore. In caso di discordanza fra uscita di comando e stato viene generato allarme A40.
Serbatoio vuoto	Serbatoio troppo vuoto. Con contatto aperto genera allarme A46. La pompa di rabbocco viene arrestata. Può lavorare indipendentemente da start-stop.
Start rabbocco	Sensore di livello basso del serbatoio. Con contatto aperto la pompa di rabbocco viene avviata.
Stop rabbocco	Serbatoio pieno. Con contatto chiuso la pompa di rabbocco viene arrestata.
Serbatoio troppo pieno	Serbatoio troppo pieno. Con contatto chiuso genera allarme A47. La pompa di rabbocco viene arrestata. Può lavorare indipendentemente da start-stop.
Blocco tastiera	Blocca il funzionamento della tastiera frontale, ad esclusione di tasti di navigazione delle pagine..
Blocca gruppo e tastiera	Blocca generatore e tastiera.
Livello liquido radiatore	Con ingresso attivato viene generato allarme A49 Basso liquido radiatore.
Sirena OFF	Disabilita la sirena.
Allarme stato interruttore	In modalità manuale e con ingresso OFF, viene inibito l'avviamento provocando l'allarme A50 interruttore chiuso. In manuale questa funzione viene utilizzata quando non si utilizza il teleruttore generatore ma viene utilizzato un interruttore comandato manualmente. Questa funzione è necessaria per avviare il generatore essendo certi che il carico non sia collegato. In modalità AUT e con ingresso ON viene inibito l'avviamento provocando l'allarme A51 interruttore aperto. Questa funzione è necessaria per non avviare il generatore a vuoto con consumo inutile di carburante.
Allarme caricabatteria	Con ingresso attivato, segnala allarme A52 Avaria caricabatteria esterno. L'allarme viene generato solo con tensione rete presente.
Inibizione allarmi	Permette, se attivato, di disabilitare gli allarmi con la proprietà Inibizione allarmi attivata.
Reset Allarmi	Reset degli allarmi ritenitivi la cui condizione scatenante è cessata.
Menu comandi C(x)	Esegue il comando del menu comandi definito dal parametro indice (x).
Simula tasto OFF	La chiusura dell'ingresso equivale alla pressione del tasto
Simula tasto MAN	La chiusura dell'ingresso equivale alla pressione del tasto
Simula tasto AUTO	La chiusura dell'ingresso equivale alla pressione del tasto
Simula tasto TEST	La chiusura dell'ingresso equivale alla pressione del tasto
Simula tasto START	La chiusura dell'ingresso equivale alla pressione del tasto
Simula tasto STOP	La chiusura dell'ingresso equivale alla pressione del tasto
Simula tasto MAINS	La chiusura dell'ingresso equivale alla pressione del tasto
Simula tasto GEN	La chiusura dell'ingresso equivale alla pressione del tasto
Furto carburante	Quando attivato genera allarme furto carburante, in alternativa al riconoscimento del furto carburante da livello analogico.
Inibizione test automatico	Impedisce esecuzione test automatico
Test LED	Accende tutti i LED sul frontale (test lampade)
Selezione Configurazione (x)	Seleziona la configurazione fra le quattro possibili. Il peso in codice binario è definito con il parametro indice (x). Vedere capitolo Configurazioni multiple.
Acqua nel carburante	Genera allarme A58 Acqua nel carburante

Tabella funzioni uscite

- La tabella seguente riporta tutte le funzioni che possono essere associate alle uscite digitali programmabili OUTn.
- Ciascuna uscita può essere poi impostato in modo da avere funzione normale o invertita (NOR o REV).
- Alcuni funzioni necessitano di un ulteriore parametro numerico, definito con l'indice (x) specificato dal parametro P19.n.02.
- Vedere menu M19 Uscite programmabili per maggiori dettagli.

Funzione	Descrizione
Disabilitata	Uscita disabilitata
Configurabile	Libera configurazione utente. Da usarsi ad esempio se l'uscita viene utilizzata in una logica PLC.
Chiusura contattore / interruttore rete	Comando chiusura teleruttore / interruttore rete. Non disponibile su RGK800SA.
Chiusura contattore / interruttore generatore	Comando chiusura teleruttore / interruttore generatore
Apertura interruttore rete	Comando apertura interruttore rete. Non disponibile su RGK800SA.
Apertura interruttore generatore	Comando apertura interruttore generatore.
Apertura rete / generatore	Apertura entrambi interruttori / posizione neutra commutatore motorizzato.
Motorino di avviamento	Alimenta il motorino d'avviamento.
EV carburante	Eccita la valvola carburante.
Alimentazione ECU	Alimenta ECU motore.
Allarme globale	Uscita attivata in presenza di un qualsiasi allarme con proprietà Allarme globale attivata.

	generated in the case of discrepancy between the command output and state. Not available on RGK800SA.
GEN contactor feedback.	As above, with reference to the generator switchgear. An alarm A40 is generated in the case of discrepancy between the command output and state.
Tank empty	Tank too empty. Generates the alarm A46 with an open contact. The filling pump is stopped. Can function independently of start-stop.
Start filling.	Tank low level sensor. The filling pump is started with an open contact.
Stop filling	Tank full The filling pump is stopped with a closed contact.
Tank too full	Tank too full. Generates the alarm A47 with a closed contact. The filling pump is stopped. Can function independently of start-stop.
Keyboard lock	Inhibits the functions of the front keyboard.
Block genset and keyboard	Block generator and keyboard.
Radiator coolant level	The alarm A49 Radiator liquid low is generated with the input enabled.
Siren OFF	Disables the siren.
Circuit breaker state alarm	In the manual mode and with input ON, starting is inhibited, generating the alarm A50 Circuit breaker closed. In manual mode this function is used when the generator contactor isn't used and a thermal magnetic circuit breaker is used. This function is required to start the generator when certain the load is disconnected. In AUT mode and with input OFF, starting is inhibited, generating the alarm A51 Circuit breaker open. This function is required to prevent starting the generator and consuming fuel needlessly.
Battery charger alarm	With the input enabled, generates the alarm A52 External battery charger fault. The alarm is only generated when there is mains voltage.
Inhibit alarms	If enabled, disables the alarms with the property Inhibit alarms activated.
Alarm Reset.	Resets the retained alarms for which the condition that triggered the same has ceased.
Commands menu C(x)	Executes the command from the commands menu defined by index parameter (x).
Simulate OFF key	Closing the input is the equivalent of pressing the key.
Simulate MAN key	Closing the input is the equivalent of pressing the key.
Simulate AUTO key	Closing the input is the equivalent of pressing the key.
Simulate TEST key	Closing the input is the equivalent of pressing the key.
Simulate START key	Closing the input is the equivalent of pressing the key.
Simulate STOP key	Closing the input is the equivalent of pressing the key.
Simulate MAINS key	Closing the input is the equivalent of pressing the key.
Simulate GEN key	Closing the input is the equivalent of pressing the key.
Fuel theft	When active, it generates Fuel theft alarm, a san alternative to the fuel theft detection made by analog level.
Inhibit automatic test	Inhibits the automatic test
LED key	Turns all the LEDS on the front panel on (test lamps)
Select configuration (x)	Selects one of four possible configurations. The binary code weight is defined by index parameter (x). See chapter Multiple configurations.
Water in fuel	Generates the alarm A58 Water in fuel

Output function table

- The following table shows all the functions that can be attributed to the OUTn programmable digital inputs.
- Each output can be configured so it has a normal or reverse (NOR or REV) function.
- Some functions require another numeric parameter, defined in the index (x) specified by parameter P19.n.02.
- See menu M19 Programmable outputs for more details.

Function	Description
Disabled	Output disabled
Configurable	User configuration free to use for example if the output is used in PLC logic.
Close mains contactor/circuit breaker	Command to close mains contactor/circuit breaker Not available on RGK800SA.
Close generator contactor/circuit breaker	Command to close generator contactor/circuit breaker
Open mains circuit breaker	Command to open mains circuit breaker Not available on RGK800SA.
Open generator circuit breaker	Command to open generator circuit breaker
Open mains/generator	Open both circuit breakers/neutral position of motorized commutator
Starter motor	Powers the starter motor
Fuel solenoid valve	Energizes the fuel valve
ECU power	Powers the engine ECU
Global alarm	Output enabled in the presence of any alarm with the Global alarm propriety enabled.

Sirena	Alimenta la sirena di segnalazione acustica.
Deceleratore	Comando di riduzione giri in fase di avviamento. Eccitata appena motore parte, per una durata max impostata.
Acceleratore	Funzione opposta alla precedente.
Magnete stop	Uscita eccitata per arrestare il motore.
Candelette	Attivazione candelette preriscaldamento prima di avviamento.
Valvola gas	Elettrovalvola mandata gas. Apertura ritardata rispetto a inserimento motorino di avviamento e chiusura anticipata rispetto a comando di arresto.
Valvola aria	Valvola strozzatura aspirazione all'avviamento per motori a benzina (choke).
Valvola cicchetto	Iniezione benzina per avviamento motori a gas. Il relè per la funzione cicchetto viene attivato in concomitanza alla eccitazione della elettrovalvola gas solo durante il primo tentativo di avviamento.
Carico fittizio step (x)	Comanda i contattori per l'inserimento del carico fittizio (x=1...4).
Sgancio carichi non prioritari step (x)	Comanda i contattori per sgancio carichi non prioritari (x=1...4)
Aria compressa	Avviamento motore tramite aria compressa, in alternativa / alternanza con motorino di avviamento. Vedere parametro P11.26.
Modo funzionamento	Uscita eccitata quando l'RGK800 si trova in una delle modalità impostate con il parametro P23.13.
Stato tensione rete	Eccitata quando la tensione rete rientra nei limiti impostati. Non disponibile su RGK800SA.
Stato tensione generatore	Eccitata quando tensione generatore rientra nei limiti impostati.
Motore in moto	Eccitata quando il motore è in moto.
Modo OFF	Eccitata quando l'RGK800 si trova in modalità OFF.
Modo MAN	Eccitata quando l'RGK800 si trova in modalità MAN.
Modo AUT	Eccitata quando l'RGK800 si trova in modalità AUT.
Modo TEST	Eccitata quando l'RGK800 si trova in modalità TEST.
Raffreddamento in corso	Eccitata quando è in corso il ciclo di raffreddamento.
Generatore pronto	Indica RGK800 in modalità automatico senza alcun allarme attivo.
Valvola preriscaldamento	Controlla la valvola preriscaldamento carburante. Vedere descrizione parametri P11.06 e P11.07.
Scaldiglia (riscaldatore)	Controlla l'uscita di comando del riscaldatore, pilotato dalla temperatura del motore e dai parametri P09.10 e P09.11.
Pompa rabbocco carburante	Controlla la pompa rabbocco carburante. Può essere controllata dagli ingressi di start e stop oppure dal livello misurato dal sensore analogico. Vedere parametri P10.09 e P10.10.
Remotazione allarmi/stati	Uscita pulsata per la comunicazione con l'unità RGKRR quando effettuata in modalità I/O digitale.
Limiti LIM (x)	Uscita controllata dallo stato della soglia limite LIM(x) (x=1..16) viene definito dal parametro indice.
Impulsi PUL (x)	Uscita controllata dallo stato della variabile impulsi energia PUL(x) (x=1..6).
Flag PLC(x)	Uscita comandata da flag PLCx (x=1..32).
Variabile remota REM(x)	Uscita comandata da variabile remota REMx (x=1..16).
Allarmi A01-Axx	Uscita eccitata quando l'allarme Axx è attivo (xx=1...numero allarmi).
Allarmi UA1..UAx	Uscita eccitata quando l'allarme UAx è attivo (x=1...8).

Menu comandi

- Il menu comandi permette di eseguire operazioni saltuarie quali azzeramenti di misure, contatori, allarmi, ecc.
- Se è stata immessa la password per accesso avanzato, allora tramite il menu comandi è anche possibile effettuare delle operazioni automatiche utili ai fini della configurazione dello strumento.
- Nella seguente tabella sono riportate le funzioni disponibili con il menu comandi, divise a seconda del livello di accesso necessario.

COD.	COMANDO	LIVELLO ACCESSO	DESCRIZIONE
C01	Reset intervallo manutenzione 1	Utente	Azzerare l'allarme di manutenzione MNT1 e ricarica il contatore della manutenzione alle ore impostate.
C02	Reset intervallo manutenzione 2	Utente	Come sopra, riferito a MNT2.
C03	Reset intervallo manutenzione 3	Utente	Come sopra, riferito a MNT3.
C04	Reset contaore motore parziale	Utente	Azzerare il contaore parziale del motore.
C05	Reset contaore parziale energia rete	Utente	Azzerare il contaore parziale della energia rete.
C06	Reset contaore parziale energia generatore.	Utente	Azzerare il contaore parziale della energia generatore.
C07	Reset contatori generici CNTx	Utente	Azzerare i contatori generici CNTx.
C08	Reset stato limiti LIMx	Utente	Azzerare lo stato dei limiti LIMx ritenitivi
C09	Azzerare minimi / massimi misure	Utente	Azzerare i picchi registrati delle misure
C10	Reset contaore motore totale	Avanzato	Azzerare il contaore totale del motore.
C11	Impostazione contaore motore	Avanzato	Permette di impostare il contaore totale del motore ad un valore desiderato.

Siren	Powers the siren
Decelerator	Reduce rpm in starting phase Energized as soon as the engine starts, for the max duration set.
Accelerator	Opposite function to the above.
Stop magnets	Output energized for engine stop
Glowplugs	Glowplug preheating before starting
Gas valve	Gas delivery solenoid valve. Opening delayed in relation to starter motor activation, and closed in advance in relation to stop command.
Choke	Choke for petrol engines
Priming valve	Petrol injection for starting gas-fuelled engines The priming valve relay is enabled at the same time as the gas solenoid valve only during the first start attempt.
Dummy load steps (x)	Controls the contactors to switch in the dummy load (x=1...4).
Load shedding steps (x)	Controls the contactors for load shedding (x=1...4)
Compressed air	Start engine with compressed air, as an alternative/alternating with starter motor. See parameter P11.26.
Operating mode	Output energized when the RGK800 is in one of the modes set with parameter P23.13.
Mains voltage state	Energized when the mains voltage returns within the set limits. Not available on RGK800SA.
Generator voltage state	Energized when the generator voltage returns within the set limits.
Engine running	Energized when the engine is running.
OFF mode	Energized when the RGK800 is OFF.
MAN mode	Energized when the RGK800 is in MAN mode.
AUT mode	Energized when the RGK800 is in AUT mode.
TEST mode	Energized when the RGK800 is in TEST mode.
Cooling	Energized when the cooling cycle is running
Generator ready	Indicates the RGK800 is in automatic mode and there are no active alarms.
Preheating valve	Controls the fuel preheating valve See description of parameters P11.06 and P11.07.
Heater	Controls the engine heater, using engine temperature reading and parameters P09.10 and P09.11.
Fuel filling pump	Controls the fuel filling pump Can be controlled by the start and stop inputs, or on the basis of the level detected by the analog sensor. See parameters P10.09 and P10.10.
Remote alarms/states	Pulse output for communication with the RGKRR in digital I/O mode.
LIM limits (x)	Output controlled by the state of the limit threshold LIM(x) (x=1..16) defined by the index parameter.
PUL pulses (x)	Output controlled by the state of the energy pulse variables PUL(x) (x=1..6).
Flag PLC(x)	Output controlled by flag PLCx (x=1..32).
REM(x) remote variable	Output controlled by remote variable REMx (x=1..16).
Alarms A01-Axx	Output energized with alarm Axx is enabled (xx=1...alarms number).
Alarms UA1..UAx	Output energized with alarm UAx is enabled (x=1...8).

Commands menu

- The commands menu allows executing some occasional operations like reading peaks resetting, counters clearing, alarms reset, etc.
- If the Advanced level password has been entered, then the commands menu allows executing the automatic operations useful for the device configuration.
- The following table lists the functions available in the commands menu, divided by the access level required.

COD.	COMMAND	ACCESS LEVEL	DESCRIPTION
C01	Reset maintenance interval 1	User	Resets maintenance alarm MNT1 and recharges the counter with the set number of hours.
C02	Reset maintenance interval 2	User	As above, with reference to MNT2.
C03	Reset maintenance interval 3	User	As above, with reference to MNT3.
C04	Reset engine partial hour counter	User	Resets the partial counter of the engine.
C05	Reset mains partial counter.	User	Resets the mains partial energy counter.
C06	Reset generator partial counter.	User	Resets the generator partial energy counter.
C07	Reset generic counters CNTx	User	Resets generic counters CNTx.
C08	Reset High/ low	User	Resets High/low peaks of the measures
C09	Reset engine total hour counter	Advanced	Resets the total counter of the engine.
C10	Engine hour counter settings	Advanced	Lets you set the total hour counter of the engine to the desired value.
C11	Reset no. starts counter	Advanced	Resets counter for the number of attempted starts and the percentage of successful attempts.

C12	Reset contatore avviamenti	Avanzato	Azzerà il contatore dei tentativi di avviamento e la percentuale di tentativi riusciti.
C13	Reset contatori chiusure	Avanzato	Azzerà il contatore delle prese di carico.
C14	Reset contatore totale energia rete	Avanzato	Azzerà il contatore totale della energia rete. (solo per RGK800)
C15	Reset contatore totale energia generatore.	Avanzato	Azzerà il contatore totale della energia generatore.
C16	Ricarica ore di noleggio	Avanzato	Ricarica il timer del noleggio al valore impostato.
C17	Reset lista eventi	Avanzato	Azzerà la lista della storia eventi.
C18	Ripristino parametri a default	Avanzato	Reimposta tutti i parametri del menu setup al default di fabbrica.
C19	Salva parametri nella memoria backup	Avanzato	Esegue una copia dei parametri attualmente impostati in una area di backup per futuro ripristino.
C20	Ricarica parametri dalla memoria backup	Avanzato	Trasferisce i parametri salvati in memoria di backup nella memoria delle impostazioni attive.
C21	Spurgo elettrovalvola	Avanzato	Eccita l'uscita elettrovalvola carburante senza avviare il motore. L'uscita rimane attiva per 5 minuti max o fino a quando si preme il tasto OFF.
C22	Forzatura I/O	Avanzato	Abilita la modalità collaudo che permette di eccitare manualmente qualsiasi uscita. Attenzione! In questa modalità la responsabilità del comando delle uscite è completamente affidata all'installatore.
C23	Regolazione offset sensori resistivi	Avanzato	Permette di tarare i sensori resistivi, aggiungendo/togliendo un valore in Ohm alla resistenza misurata dai sensori resistivi, per compensare lunghezza dei cavi o offset di resistenza. La taratura viene fatta visualizzando il valore misurato in grandezze ingegneristiche.
C24	Azzeramento programma PLC	Avanzato	Cancela il programma con la logica PLC dalla memoria interna dell'RGK800.

- Una volta selezionato il comando desiderato, premere ✓ per eseguirlo. Lo strumento chiederà una conferma. Premendo nuovamente ✓ il comando verrà eseguito.
- Per annullare l'esecuzione di un comando selezionato premere OFF.
- Per abbandonare il menu comandi premere OFF.

Installazione

- RGK800 è destinato al montaggio da incasso. Con il corretto montaggio garantisce una protezione frontale IP65.
- Inserire il sistema nel foro del pannello, accertandosi che la guarnizione sia posizionata correttamente fra il pannello e la cornice dello strumento.
- Accertarsi che la linguetta della etichetta di personalizzazione non rimanga piegata sotto la guarnizione compromettendone la tenuta, ma che sia posizionata correttamente all'interno del quadro.
- Dall'interno del quadro, per ciascuna delle quattro clips di fissaggio, posizionare la clip metallica nell'apposito foro sui fianchi del contenitore, quindi spostarla indietro per inserire il gancio nella sede.



- Ripetere l'operazione per le quattro clips.
- Stringere la vite di fissaggio con una coppia massima di 0,5Nm
- Nel caso si renda necessario smontare l'apparecchio, allentare le quattro viti e procedere in ordine inverso.
- Per i collegamenti elettrici fare riferimento agli schemi di connessione riportati nell'apposito capitolo e alle prescrizioni riportate nella tabella delle caratteristiche tecniche.

C12	Reset starting counter	Advanced	Resets the starting attempts counter and the successful starts percentage.
C13	Reset closing counters	Advanced	Resets the generator on-load counter.
C14	Reset mains total counter.	Advanced	Resets the mains total energy counter. (only for RGK800)
C15	Reset generator total counter.	Advanced	Resets the generator total energy counter.
C16	Reload rent hours	Advanced	Reloads rent timer to set value.
C17	Reset events list	Advanced	Resets the list of historical events.
C18	Reset default parameters	Advanced	Resets all the parameters in the setup menu to the default values.
C19	Save parameters in backup memory	Advanced	Copies the parameters currently set to a backup for restoring in the future.
C20	Reload parameters from backup memory	Advanced	Transfers the parameters saved in the backup memory to the active settings memory.
C21	Fuel purge	Advanced	Energizes the fuel valve without starting the engine. The valve remains energized for max 5 min. or until the OFF mode is selected.
C22	Forced I/O	Advanced	Enables test mode so you can manually energize any output. Warning! In this mode the installer alone is responsible for the output commands.
C23	Resistive sensors offset regulation	Advanced	Lets you calibrate the resistive sensors, adding/subtracting a value in Ohms to/from the resistance measured by the resistive sensors, to compensate for cable length or resistance offset. The calibration displays the measured value in engineering magnitudes.
C24	Reset PLC program	Advanced	Deletes the program with the PLC logic from the internal memory of the RGK800.

- Once the required command has been selected, press ✓ to execute it. The device will prompt for a confirmation. Pressing ✓ again, the command will be executed.
- To cancel the command execution press OFF.
- To quit command menu press OFF.

Installation

- RGK800 is designed for flush-mount installation. With proper mounting, it guarantees IP65 front protection.
- Insert the device into the panel hole, making sure that the gasket is properly positioned between the panel and the device front frame.
- Make sure the tongue of the custom label doesn't get trapped under the gasket and break the seal. It should be positioned inside the board.
- From inside the panel, for each four of the fixing clips, position the clip in its square hole on the housing side, then move it backwards in order to position the hook.

- Repeat the same operation for the four clips.
- Tighten the fixing screw with a maximum torque of 0,5Nm.
- In case it is necessary to dismount the system, repeat the steps in opposite order.
- For the electrical connection see the wiring diagrams in the dedicated chapter and the requirements reported in the technical characteristics table.

Schema di collegamento per gruppi elettrogeni trifase con alternatore carica batteria preaccitato
 Wiring diagram for three-phase generating set with pre-energised battery charger alternator

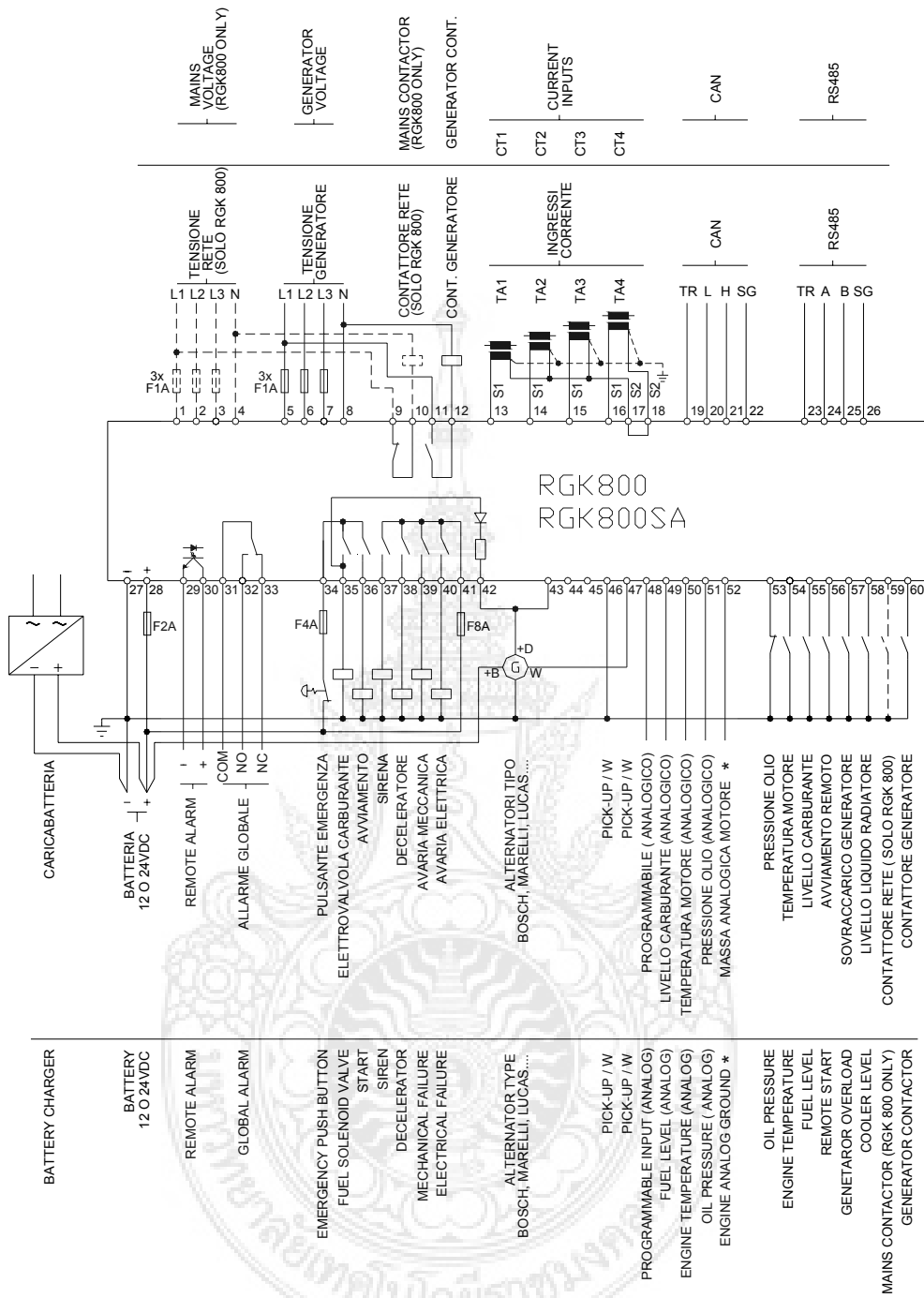

- * Massa di riferimento per sensori analogici da collegare direttamente sul blocco motore.
- * Reference earth for analog sensors to be connected directly on the engine block.

	NOTE	NOTES
	I morsetti S2 sono internamente connessi fra di loro.	S2 terminals are internally interconnected.
	Le parti tratteggiate si riferiscono all'utilizzo del controllo RGK 800	The dotted section refers to use with RGK800 control

	Connessione CANbus	CANbus connection
	La connessione CANbus prevede due resistenze di terminazione da 120 Ohm agli estremi del bus. Per collegare la resistenza incorporata nella scheda RGK800 effettuare un ponte fra TR e CAN-L.	The CANbus connection has two 120-Ohm termination resistors at both ends of the bus. To connect the resistor incorporated in the RGK800 board, jumper TR and CAN-L.

Connessioni per gruppo elettrogeno monofase <i>Wiring for single-phase generating set</i>	Connessioni per gruppo elettrogeno bifase <i>Wiring for two-phase generating set</i>
---	--

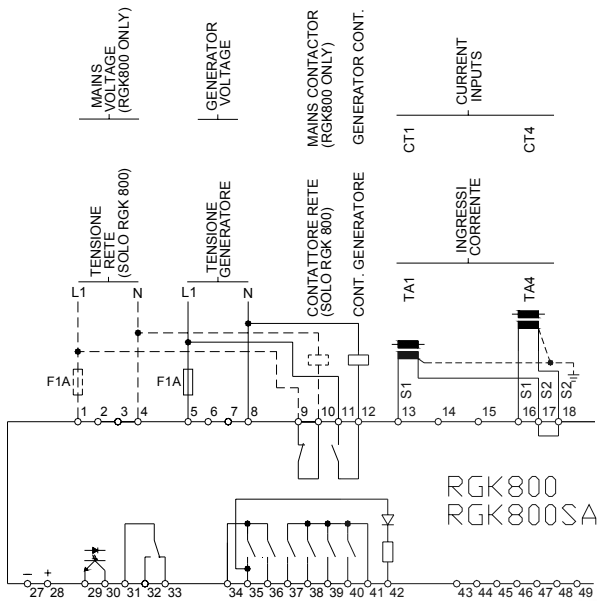

NOTE

I morsetti S2 sono internamente connessi fra di loro.
 Le parti tratteggiate si riferiscono all'utilizzo del controllo RGK 800

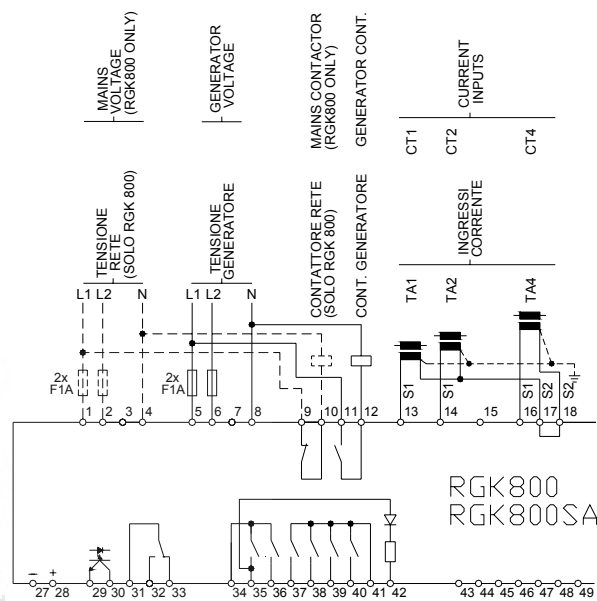

NOTES

S2 terminals are internally interconnected.
 The dotted section refers to use with RGK 800 control.

Connessioni per gruppo elettrogeno con alternatore carica batteria a magneti permanenti <i>Wiring for generating set with permanent magnet battery charger alternator</i>	Connessioni per gruppo elettrogeno rilevamento velocità da pick-up <i>Wiring for generating set with pick-up speed detector</i>
---	---

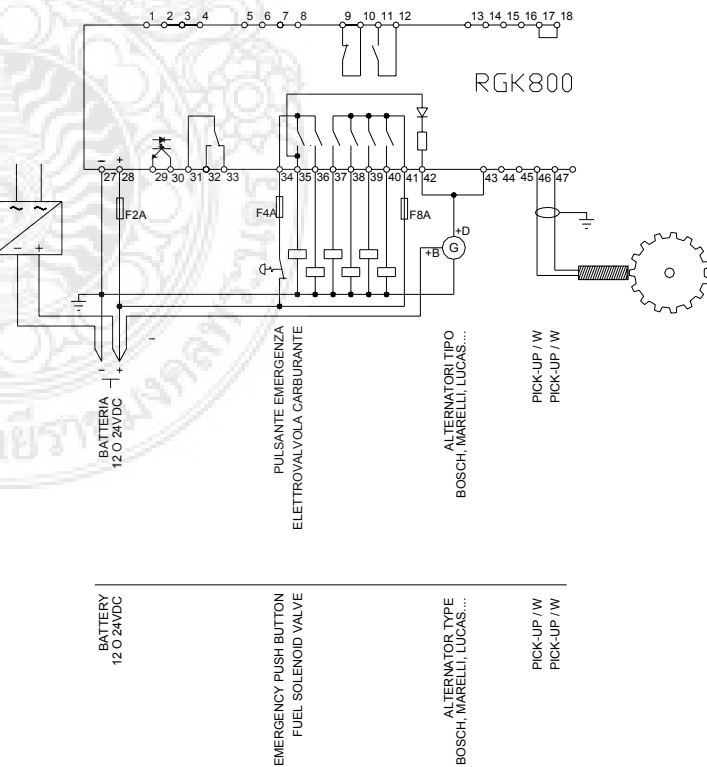
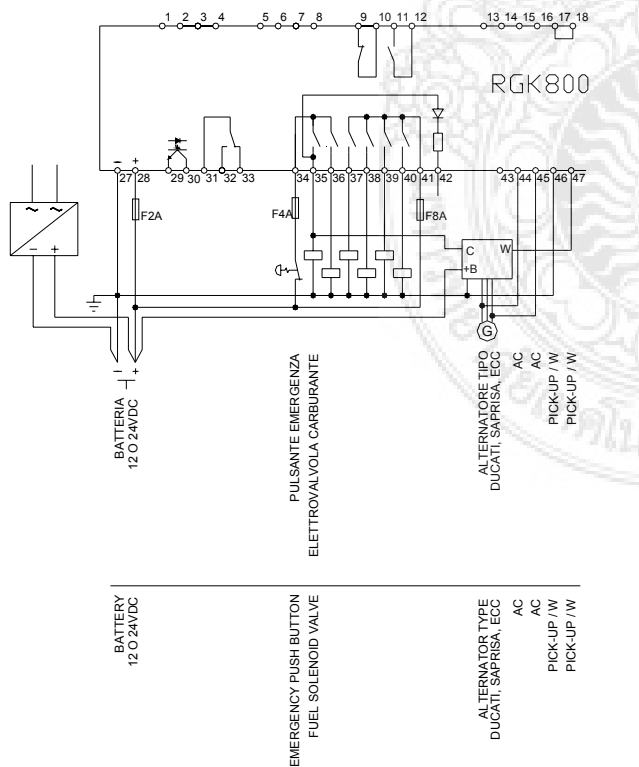

Connessioni per misura corrente dispersa
Wiring for earth fault measure

Uscita RA utilizzata come comando relè
RA output used as relay driver

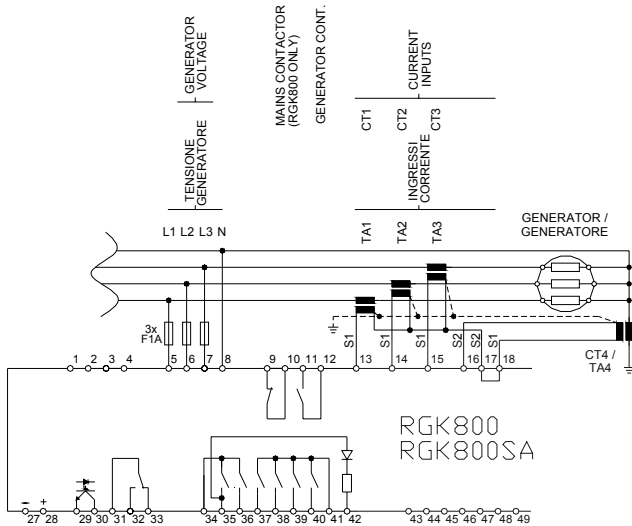

 **Non effettua protezione**
Not as protection

Uscita NPN
NPN output

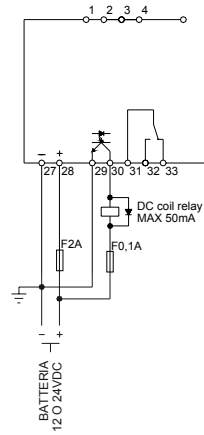

Uscita PNP
PNP output

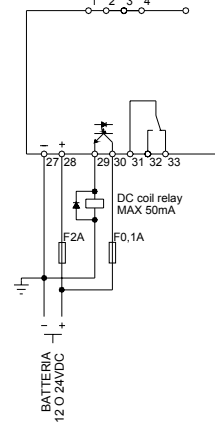

Collegamento interfaccia RS-485
RS-485 interface wiring

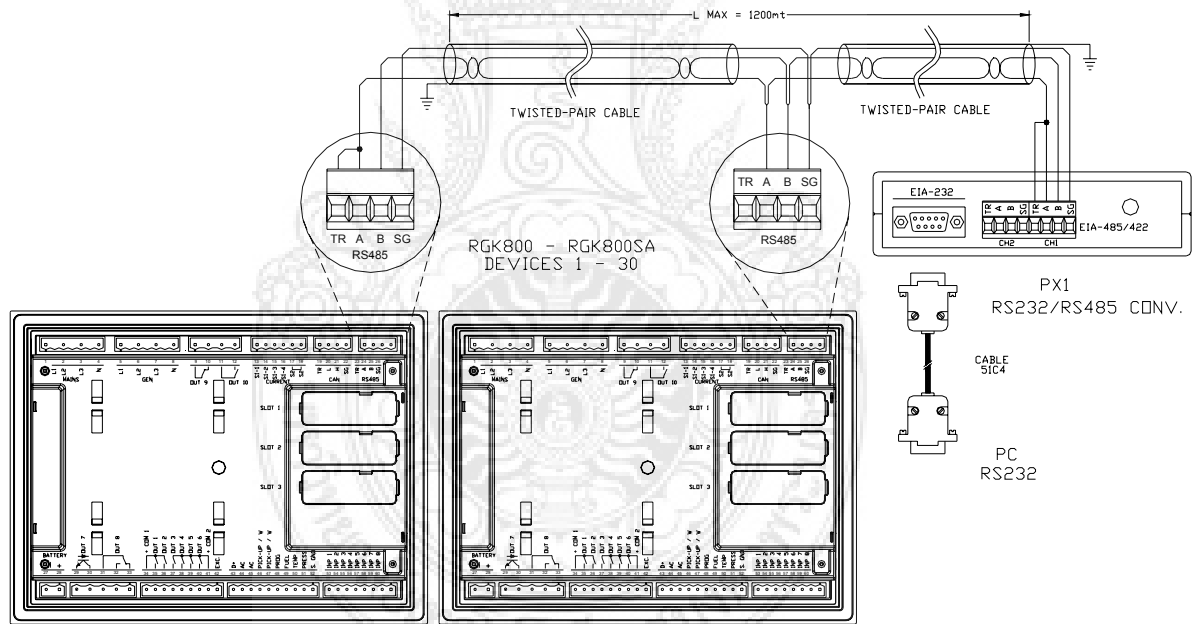

Disposizione morsetti

Terminals position

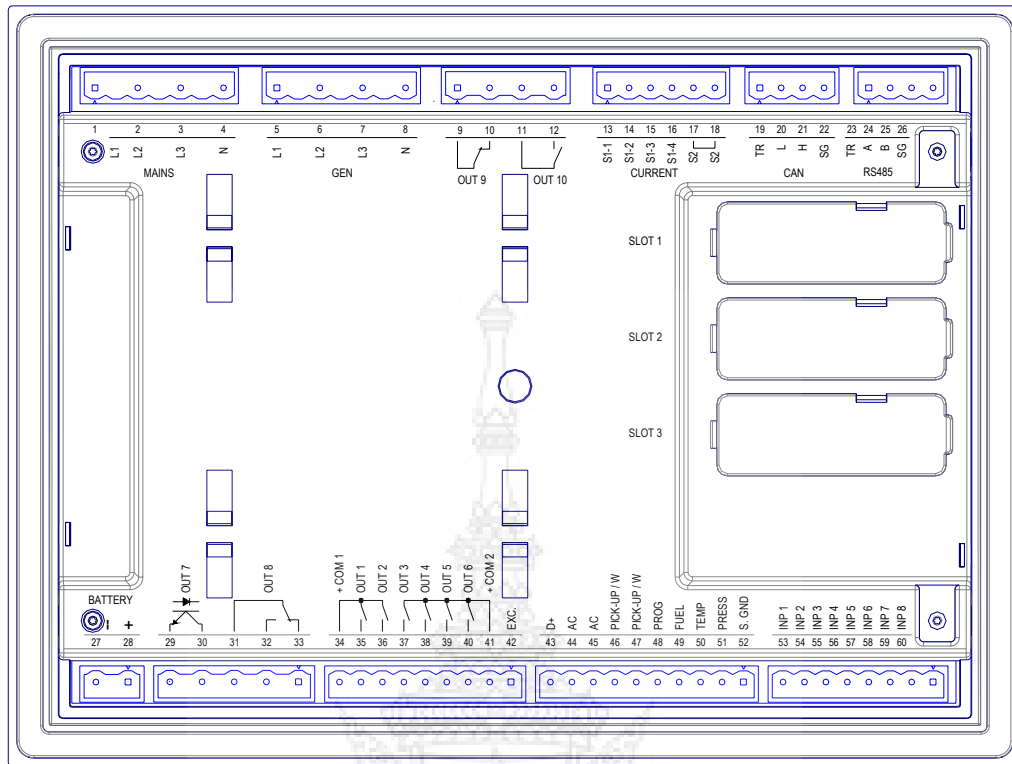

Dimensioni meccaniche (mm)

Mechanical dimensions (mm)

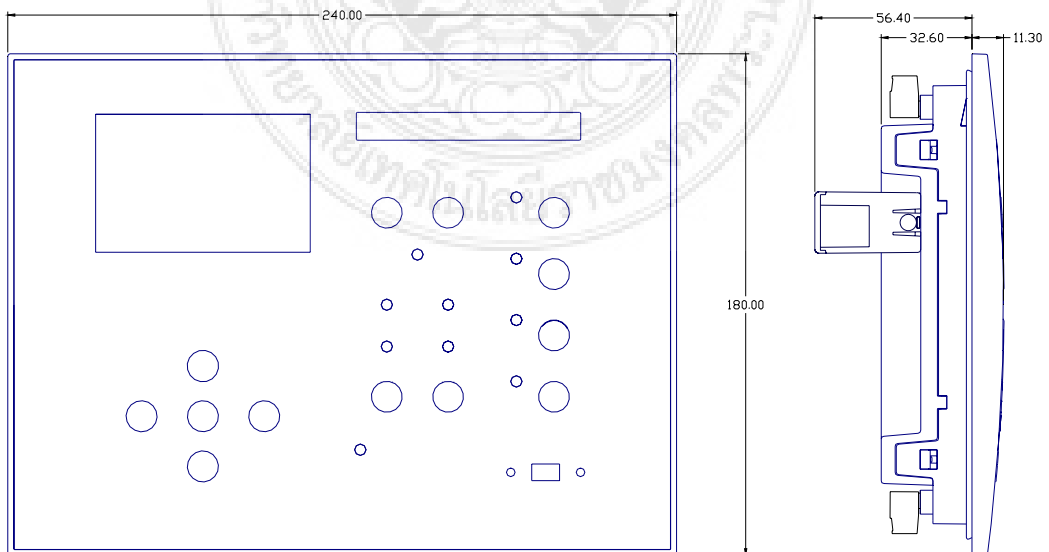

Foratura pannello (mm)

Front panel protection (mm)

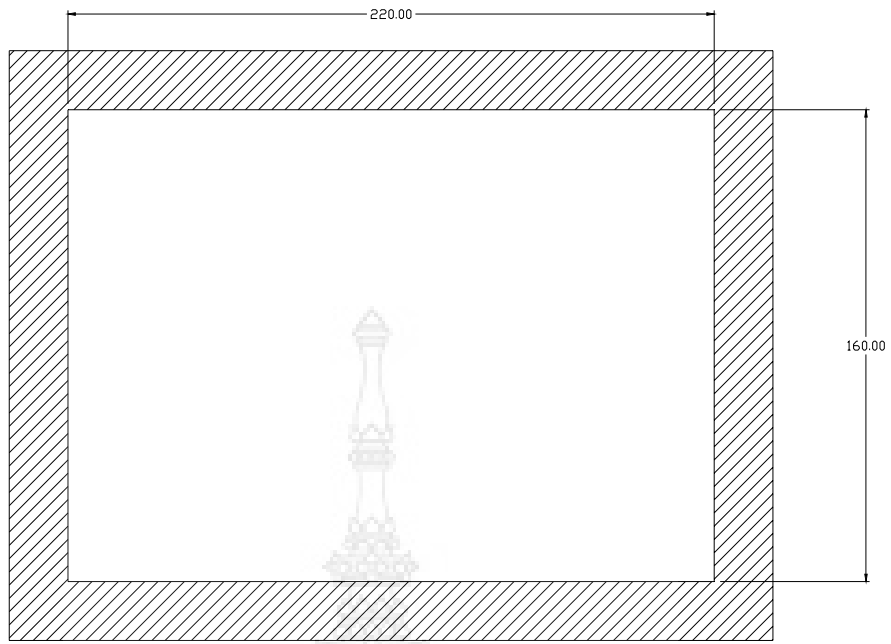

Caratteristiche tecniche

Alimentazione	
Tensione nominale di batteria	12 o 24VDC indifferentemente
Corrente massima assorbita	400mA a 12VDC e 200mA a 24VDC
Potenza massima assorbita/dissipata	4,8W
Campo di funzionamento	7...33VDC
Tensione minima all'avviamento	5,5VDC
Corrente di stand-by	70mA a 12VDC e 40mA a 24VDC
Immunità alle micro interruzioni	150ms
Ingressi digitali	
Tipo d'ingresso	negativo
Corrente d'ingresso	≤10mA
Segnale d'ingresso basso	≤1,5V (tipico 2,9V)
Segnale d'ingresso alto	≥5,3V (tipico 4,3V)
Ritardo del segnale d'ingresso	≥50ms
Ingresso di velocità "W"	
Tipo d'ingresso	Accoppiamento AC
Campo di tensione	2,4...75Vpp
Campo di frequenza	40...2000Hz
Ingresso pick-up	
Tipo d'ingresso	Accoppiamento AC
Campo di tensione	Alta sensibilità: 1,6...60Vpp – 0,6...21VRMS Bassa sensibilità: 4,8...150Vpp – 1,7...53VRMS
Campo di frequenza	20Hz...10000Hz
Impedenza d'ingresso	> 100kΩ
Ingresso 500giri alternatore carica batteria a magneti permanenti	
Tipo d'ingresso	Accoppiamento AC
Campo di funzionamento	0...44VAC
Ingresso 500giri alternatore carica batteria preexcitato	
Campo di funzionamento	0...44VDC
Corrente d'ingresso max	12mA
Tensione max al terminale +D	12 o 24VDC (tensione di batteria)
Corrente di eccitazione (morsetto 42)	230mA a 12VDC o 130mA a 24VDC
Ingresso voltmetrico rete e generatore	
Tensione nominale Ue max	600VAC L-L (346VAC L-N)
Campo di misura	50...720V L-L (415VAC L-N)
Campo di frequenza	45...65Hz – 360...440Hz
Tipo di misura	Vero valore efficace (TRMS)
Impedenza dell'ingresso di misura	> 0,55MΩ L-N > 1,10MΩ L-L
Modalità di collegamento	Linea monofase, bifase, trifase con o senza neutro e trifase bilanciato
Ingressi amperometrici	
Corrente nominale Ie	1A~ o 5A~
Campo di misura	per scala 5A: 0,010 - 6A~ per scala 1A: 0,010 - 1,2A~
Tipo di ingresso	Shunt alimentati mediante trasformatore di corrente esterno (bassa tensione) 5A max.
Tipo di misura	Vero valore efficace (RMS)
Limite termico permanente	+20% Ie
Limite termico di breve durata	50A per 1 secondo
Autoconsumo	<0,6VA
Precisione misure	
Tensione rete e generatore	±0,25% f.s. ±1digit
Uscite statiche OUT1 e OUT2 (Uscite in tensione + batteria)	
Tipo di uscita	2 x 1 NO + terminale comune
Tensione d'impiego	12-24V= da batteria
Portata nominale	2A DC1 per ogni uscita
Protezioni	Sovraccarico, cortocircuito e inversione di polarità
Uscite statiche OUT3 - OUT6 (Uscite in tensione + batteria)	
Tipo di uscita	4 x 1 NO + terminale comune
Tensione d'impiego	12-24V= da batteria
Portata nominale	2A DC1 per ogni uscita
Protezioni	Sovraccarico, cortocircuito e inversione di polarità
Uscite statiche OUT7	
Tipo di uscita	NO
Tensione d'impiego	10 - 30V=
Corrente massima	50mA
Uscite a relè OUT8 (Non tensionata)	
Tipo di contatto	1 contatto scambio
Dati d'impiego UL	B300

Technical characteristics

Supply	
Battery rated voltage	12 or 24VDC indifferently
Maximum current consumption	400mA at 12VDC e 200mA at 24VDC
Maximum power consumption/dissipation	4,8W
Voltage range	7...33VDC
Minimum voltage at the starting	5.5VDC
Stand-by current	70mA at 12VDC and 40mA at 24VDC
Micro interruption immunity	150ms
Digital inputs	
Input type	Negative
Current input	≤10mA
Input "low" voltage	≤1.5V (typical 2.9V)
Input "high" voltage	≥5.3V (typical 4.3V)
Input delay	≥50ms
Speed input "W"	
Input type	AC coupling
Voltage range	2.4...75Vpp
Frequency range	40...2000Hz
Pick-up input	
Input type	AC coupling
Voltage range	High sensitivity: 1.6...60Vpp – 0.6...21VRMS Low sensitivity: 4.8...150Vpp – 1.7...53VRMS
Frequency range	20Hz...10000Hz
Measuring input impedance	>100kΩ
Engine running input (500rpm) for permanent magnet alternator	
Input type	AC coupling
Voltage range	0...44VAC
Engine running input (500rpm) for pre-excited alternator	
Voltage range	0...44VDC
Maximum input current	12mA
Maximum voltage at +D terminal	12 or 24VDC (battery voltage)
Pre-excitation current (42 terminal)	230mA 12VDC – 130mA 24VDC
Mains and generator voltage inputs	
Maximum rated voltage Ue	600VAC L-L (346VAC L-N)
Measuring range	50...720V L-L (415VAC L-N)
Frequency range	45...65Hz – 360...440Hz
Measuring method	True RMS
Measuring input impedance	> 0.55MΩ L-N > 1,10MΩ L-L
Wiring mode	Single-phase, two-phase, three-phase with or without neutral or balanced three-phase system.
Current inputs	
Rated current Ie	1A~ or 5A~
Measuring range	for 5A scale: 0.010 - 6A~ for 1A scale: 0.010 - 1.2A~
Type of input	Shunt supplied by an external current transformer (low voltage). Max. 5A
Measuring method	True RMS
Overload capacity	+20% Ie
Overload peak	50A for 1 second
Power consumption	<0.6VA
Measuring accuracy	
Mains and generator voltage	±0.25% f.s. ±1digit
SSR output OUT1 and OUT2 (+ battery voltage output)	
Output type	2 x 1 NO + one common terminal
Rated voltage	12-24V= from battery
Rated current	2A DC1 each
Protection	Overload, short circuit and reverse polarity
SSR output OUT3 - OUT6 (+ battery voltage output)	
Output type	4 x 1 NO + one common terminal
Rated voltage	12-24V= from battery
Rated current	2A DC1 each
Protection	Overload, short circuit and reverse polarity
SSR output OUT7	
Output type	NO
Rated voltage	10 - 30V=
Max current	50mA
Relay output OUT8 (voltage free)	
Contact type	1 changeover
UL Rating	B300

	30V= 1A Servizio ausiliario
Tensione d'impiego	250V~
Portata nominale a 250VAC	8A in AC1 (1,5A in AC15)
Uscite a relè OUT 9 (Non tensionata)	
Tipo di contatto	1 NC (contattore rete)
Dati d'impiego UL	B300 30V= 1A Servizio ausiliario
Tensione d'impiego	250V~ nominale (400V~ max)
Portata nominale a 250VAC	8° in AC1 (1,5° in AC15)
Uscite a relè OUT 10 (Non tensionata)	
Tipo di contatto	1 NO (contattore generatore)
Dati d'impiego UL	B300 30V= 1A Servizio ausiliario
Tensione d'impiego	250V~ nominale (400V~ max)
Portata nominale a 250VAC	8° in AC1 (1,5° in AC15)

Linee di comunicazione	
Interfaccia seriale RS485	Isolata
Baud-rate	programmabile 1200...38400 bps
Tensione di isolamento (RS485-VBatt.)	1kV
Interfaccia CANbus	Non isolata
Orologio datario	
Riserva di carica	Condensatore di back-up
Funzionamento senza tensione di alimentazione	Circa 12...15 giorni
Tensione di isolamento	
Tensione nominale d'isolamento Ui	600V~
Tensione nomi. di tenuta a impulso Uimp	9,5kV
Tensione di tenuta a frequenza d'esercizio	5,2kV
Condizioni ambientali di funzionamento	
Temperatura d'impiego	-30 - +70°C
Temperatura di stoccaggio	-30 - +80°C
Umidità relativa	<80% (IEC/EN 60068-2-78)
Inquinamento ambiente massimo	Grado 2
Categoria di sovratensione	3
Categoria di misura	III
Sequenza climatica	Z/ABDM (IEC/EN 60068-2-61)
Resistenza agli urti	15g (IEC/EN 60068-2-27)
Resistenza alle vibrazioni	0.7g (IEC/EN 60068-2-6)
Connessioni	
Tipo di morsetti	Estraibili
Sezione conduttori (min e max)	0,2...2,5 mmq (24÷12 AWG)
Dati d'impiego UL	0,75...2,5 mm² (18-12 AWG)
Sezione conduttori (min e max)	
Coppia di serraggio	0,56 Nm (5 LBin)
Contenitore	
Esecuzione	Da incasso
Materiale	
Grado di protezione frontale	IP65 sul fronte - IP20 sui morsetti
Peso	????
Omologazioni e conformità	
cULus	In corso
Conformità a norme	IEC/EN 61010-1, IEC/EN 61000-6-2 IEC/ EN 61000-6-3 UL508 e CSA C22.2-N°14
UL « Marking »	Use 60°C/75°C copper (CU) conductor only AWG Range: 24 - 12 AWG stranded or solid Field Wiring Terminals Tightening Torque: 4.5lb.in

	30V= 1A Pilot Duty
Rated voltage	250V~
Rated current at 250VAC	8A AC1 (1,5A AC15)
Relay output OUT 9 (voltage free)	
Contact type	1 NC (mains contactor)
UL Rating	B300 30V= 1A Pilot Duty
Rated voltage	250V~ (400V~ max)
Rated current at 250VAC	8A AC1 (1,5A AC15)
Relay output OUT109 (voltage free)	
Contact type	1 NO (generator contactor)
UL Rating	B300 30V= 1A Pilot Duty
Rated voltage	250V~ (400V~ max)
Rated current at 250VAC	8A AC1 (1,5A AC15)

Communication Lines	
RS485 Serial interface (RGAM41 only)	Opto-isolated
Baud-rate	programmabile 1200...38400 bps
Voltage insulation (RS485-VBatt.)	1kV
CANbus interface	Not isolated
Real time clock	
Energy storage	Back-up capacitors
Operating time without supply voltage	About 12...15 days
Insulation voltage	
Rated insulation voltage Ui	600V~
Rated impulse withstand voltage Uimp	9.5kV
Power frequency withstand voltage	5,2kV
Ambient operating conditions	
Operating temperature	-30 - +70°C
Storage temperature	-30 - +80°C
Relative humidity	<80% (IEC/EN 60068-2-78)
Maximum pollution degree	2
Overvoltage category	3
Measurement category	III
Climatic sequence	Z/ABDM (IEC/EN 60068-2-61)
Shock resistance	15g (IEC/EN 60068-2-27)
Vibration resistance	0.7g (IEC/EN 60068-2-6)
Connections	
Terminal type	Plug-in / removable
Cable cross section (min... max)	0.2...2.5 mm² (24...12 AWG)
UL Rating	0,75...2,5 mm² (18...12 AWG)
Cable cross section (min... max)	
Tightening torque	0.56 Nm (5 lbin)
Housing	
Version	Flush mount
Material	
Degree of protection	IP41 on front - IP20 terminals
Weight	????
Certifications and compliance	
cULus	Pending
Reference standards	IEC/EN 61010-1, IEC/EN 61000-6-2 IEC/ EN 61000-6-3 UL508 and CSA C22.2-N°14
UL Marking	Use 60°C/75°C copper (CU) conductor only AWG Range: 24 - 12 AWG stranded or solid Field Wiring Terminals Tightening Torque: 4.5lb.in

ประวัติผู้เขียน



ชื่อ สกุล	นายภาณุวัฒน์ ภูมิสุนทรธรรม
วันเดือนปีเกิด	วันที่ 2 มกราคม 2534
สถานที่เกิด	จังหวัด กรุงเทพมหานคร
ที่อยู่ปัจจุบัน	6/167 ซอย 48 ถนนลาดปลาเค้า แขวงจระเข้บัว เขตลาดพร้าว จังหวัด กรุงเทพฯ 10230
ประวัติการศึกษา	
พ.ศ. 2551	สำเร็จการศึกษาในระดับประกาศนียบัตรวิชาชีพ (ปวช.) สาขาวิชา ช่างไฟฟ้ากำลัง รร. ทบอ. ช่างกล ขส.ทบ.
พ.ศ. 2552	ศึกษาต่อในหลักสูตรวิศวกรรมศาสตรบัณฑิต สาขาวิชาวิศวกรรมไฟฟ้า-ไฟฟ้ากำลัง คณะวิศวกรรมศาสตร์ มหาวิทยาลัยเทคโนโลยีราชมงคลพระนคร ศูนย์ พระนครเหนือ

ประวัติผู้เขียน



ชื่อ สกุล	นายศรีณัฐ ฉลาดยิ่ง
วันเดือนปีเกิด	วันที่ 2 มีนาคม 2532
สถานที่เกิด	จังหวัด กรุงเทพมหานคร
ที่อยู่ปัจจุบัน	128/167 ม.6 ต.คลองโยง อ.พุทธมณฑล จ.นครปฐม 73170
ประวัติการศึกษา	
พ.ศ. 2551	สำเร็จการศึกษาในระดับประกาศนียบัตรวิชาชีพ (ปวช.) สาขาวิชา ช่างไฟฟ้ากำลัง วิทยาลัยเทคโนโลยีกรุงเทพ
พ.ศ. 2552	ศึกษาต่อในหลักสูตรวิศวกรรมศาสตรบัณฑิต สาขาวิชาวิศวกรรมไฟฟ้า-ไฟฟ้ากำลัง คณะวิศวกรรมศาสตร์ มหาวิทยาลัยเทคโนโลยีราชมงคลพระนคร ศูนย์ พระนครเหนือ

ประวัติผู้เขียน



ชื่อ สกุล	นายนิธิวัฒน์ อากาศวิภาต
วันเดือนปีเกิด	วันที่ 6 พฤศจิกายน 2533
สถานที่เกิด	จังหวัด กรุงเทพมหานคร
ที่อยู่ปัจจุบัน	148 ม.10 ต.สวนหลวง อ.กระทุ่มแบน จ.สมุทรสาคร 74110
ประวัติการศึกษา	
พ.ศ. 2551	สำเร็จการศึกษาในระดับประกาศนียบัตรวิชาชีพ (ปวช.) สาขาวิชา ช่างอิเล็กทรอนิกส์ รร. เทคโนโลยีสยาม
พ.ศ. 2552	ศึกษาต่อในหลักสูตรวิศวกรรมศาสตรบัณฑิต สาขาวิชาวิศวกรรมไฟฟ้า-ไฟฟ้ากำลัง คณะวิศวกรรมศาสตร์ มหาวิทยาลัยเทคโนโลยีราชมงคลพระนคร ศูนย์ พระนครเหนือ