

<http://journal.rmutp.ac.th/>

Bananas Drying Performance with a Developed Hot Air Dryer Using Waste Heat from Charcoal Production Process

Phairoach Chunkaew* Anurat Tavata Aphirak Khadwilard and Yutana Sriudom

Faculty of Engineering, Rajamangala University of Technology Lanna
41 Paholayothin Road, Mai Ngam, Muang, Tak, 63000

Received 5 October 2017; Accepted 19 February 2018

Abstract

The purpose of this research is to develop a hot air dryer using waste heat from a 200 liter kiln for drying bananas, and to investigate its drying performance. The main parts of the dryer consist of the drying chamber that has dimensions $0.71 \times 0.83 \times 0.91 \text{ m}^3$, the air circulation system and a heat exchanger, which receives waste heat from the exhaust tube and kiln surface. The dryer was developed by designing a drying chamber on the top of a 200 liter kiln to reduce heat lost in the structure and an exhaust gas heat exchanger was developed using groups of copper tubes for increasing then heat transferred to the air. The drying performances were analyzed by measuring specific drying rates and specific energy consumption. Experiments were performed under different temperatures of 60, 70 and 80 °C and at a constant velocity of 1.8 ms^{-1} . Eucalyptus was selected as the heat source. Thirty kg of peeled bananas were prepared at an initial moisture content of $241.19 \pm 31.50 \%$ dry basis and were dried until to final moisture content of $48.47 \pm 10.46 \%$ dry basis. All experiments were carried out in duplicate. For temperatures of 60, 70 and 80 °C, the average specific drying rates were 0.085 ± 0.0004 , 0.114 ± 0.0009 and $0.1277 \pm 0.010 \text{ kg}_{\text{water}} \text{ h}^{-1} \text{ kg}_{\text{solid}}^{-1}$ and the average specific energy consumptions were 1.42 ± 0.055 , 1.21 ± 0.355 and $1.04 \pm 0.074 \text{ MJ/kg}_{\text{water}}$ respectively. Some dried bananas had burned at a temperature of 80 °C so at temperature of 70 °C was the optimal condition in this experiment. This produced good color, a high specific drying rate and low specific energy consumption.

Keywords: Banana; Dryer; Performance; Waste Heat

*Corresponding Author. Tel.: +668 6732 4742, E-mail Address: phairoac@rmutl.ac.th

1. Introduction

Hot air is dry air, which is used for many dried products to remove the water from the raw material of the dried product. Electrical energy is a heat source that is easily to use and to control. Heater drying converts electric energy to heat energy for increasing the air temperature. Next, a new technology heat pump was developed in the dryer with a closed loop air system, and low temperatures of about 60 °C [1]. This technology uses power from electrical energy and results in energy saving from heat recovery from the heat pump dryer. A disadvantage of the two dryers is that, they will increase the cost of increasing air temperature in the drying process.

Dried bananas are used for eating and are agriculture goods. One way to dry bananas is to use a solar heat source, just let them to dry in the sun. This way is the easiest method and does not include payment. This drying method uses a drying time of about 5-7 days and the dried bananas are likely to be contaminated with powder and insects. To speed up the drying a parabola dome is developed for drying clean banana. This has the advantage of also protecting the bananas from dust and insects. Parabola dome drying usually takes about 4 days [2], [3]. This can be a problem during the rainy season. If the rain falls continuously more than 2 days the bananas will be lost.

Fuel wood is a widely available renewable energy source from biomass

and it is a raw material for producing charcoal. A charcoal is used to cook food in the everyday life. A 200 liter tank would be widely used in industry, such as the chemical, painting and oil industries. They are generally used as waste tanks. These tanks are therefore cheap and small and can modify into a charcoal kiln. It is new technology for charcoal production and is called the name of a 200 liter kiln [4]. This technology is easy to build, has low cost and produces high charcoal quality. A production step has excess heat with exhaust gas and loss from around the 200 liter kiln. Chunkaew *et al.* (2017)[5] focused on the waste heat from the kiln together with the exhaust heat to dry bananas. The exhaust gas heat exchanger was made from a 4 inch diameter steel tube with rectangular fins to increase the heat transfer area. The kiln surface and insulated six steel walls had a heat exchanger. The performance of dryer was performed under different air velocities 0.6 and 1.8 ms⁻¹ and a drying temperature at 60±4 °C. The best condition in this experiment was the air velocity of 1.8 ms⁻¹. Drying process before flat banana found that had long time so the charcoal product could not produce. Finally, the dryer could not increase it's temperature by more than 60 °C because more heat is lost via the air ducts and structures. In this research, a developed hot air dryer by using waste heat from charcoal production process

of a 200 liter kiln was used for drying peeled bananas by designing a drying chamber to put on the top of a 200 liter kiln to reduce the heat lost in the structure and the exhaust gas heat exchanger, was developed. The drying performance was investigated at various the temperatures greater than 60 °C to find the optimal conditions. Specific energy consumption of this paper was calculated from the electric energy used for the blower motor in unit of MJ/kg_{water}. It had not included energy of eucalyptus.

2. Materials and Methods

2.1 Experimental apparatus

Fig. 1 illustrates a developed hot air dryer using waste heat from the charcoal production process of a 200 liter kiln. The drying chamber had dimensions of 0.71x0.83x0.91 m³ and was installed on the top of a 200 liter kiln. It could contain a maximum of 6 trays of 30 kg of peeled bananas. The air circulation system used a blower with a 0.5 horsepower motor. The velocity of air could be adjusted by using an inverter. Two heat exchangers, one on the exhaust gas and another around the kiln surface were designed for wasteheat recovery. The exhaust gas heat exchanger was made from a group of copper tubes as shown in **Fig. 2A**. Heat exchange too place between the kiln surface and six insulated steel walls. At the front side of the kiln a small

door with a pocket was installed. The pocket was used to start the burning wood in the kiln. At a high enough temperature the wood could set fire to itself. The slide valve was used to control the drying temperature as shown in **Fig. 2B**.

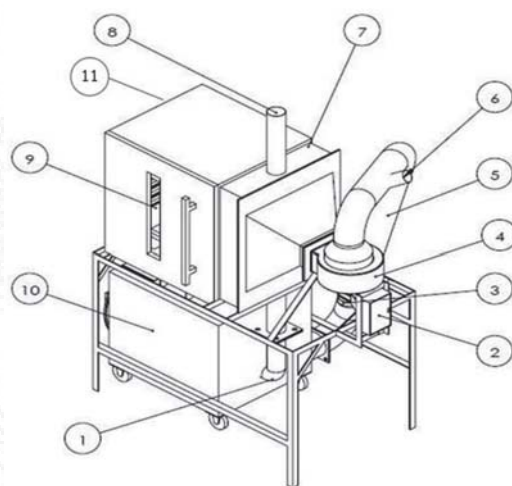

1. Outlet hole of wood vinegar, 2. Inverter, 3. Blower motor, 4. Blower, 5. Air duct, 6. Inlet ambient air, 7. Exhaust gas heat exchanger, 8. Outlet exhaust gas, 9. Drying chamber, 10. Kiln surface heat exchanger and a 200 liter kiln and 11. Exit air

Fig. 1 Apparatus of a developed 200 liter kiln waste heat recovery system



A) Exhaust gas heat exchanger



B) Kiln surface heat exchanger

Fig. 2 Exhaust gas heat exchanger and kiln surface heat exchanger

2.2 Materials

30 kg of peeled bananas were dried at a time. The initial moisture content of the peeled bananas was $241.19 \pm 31.50\%$ on a dry basis as shown in **Fig. 3 A**). The bananas were shaken put on trays and placed in the drying chamber. The dryer was stopped when the bananas were flat. The bananas were kept in a container for 12 hours and coated with a honeyed fluid, which comes from the flat bananas. Finally, the bananas were dried until a final moisture content of $48.47 \pm 10.46\%$ dry basis [6] as shown in **Fig. 3 B**).



A) Peeled bananas



B) Dried bananas

Fig. 3 Peeled bananas and dried bananas in drying chamber

Eucalyptus and charcoal burning technique, eucalyptus was selected to use to generate heat as the eucalyptus would reduce the moisture content of the surrounding air in the time period of 3 weeks as shown in **Fig. 4**. The charcoal burning technique for a 200 liter charcoal kiln was used in this study [4]. Firstly, the eucalyptus was cut to about 80 cm of length and was put in a 200 liter charcoal kiln. The smaller eucalyptus was placed on the bottom with the larger eucalyptus on top. The length of eucalyptus had taper shape so the big side of eucalyptus should arrange at the front of a 200 liter charcoal kiln. Secondly, the cover of kiln was closed

and the hot gas from burning wood at the pocket would flow in the kiln and the moisture content of the eucalyptus was reduced over 2-3 hours. Next, the eucalyptus in the kiln could burn and a slide valve was used manually operated to control the temperature in drying chamber. Thirdly, the more smoke was a brown color because of the wood vinegar. Next, the smoke was a blue color while the eucalyptus was converting into charcoal. Finally, the cooling process was achieved by closing outlet exhaust and inlet air of the kiln.

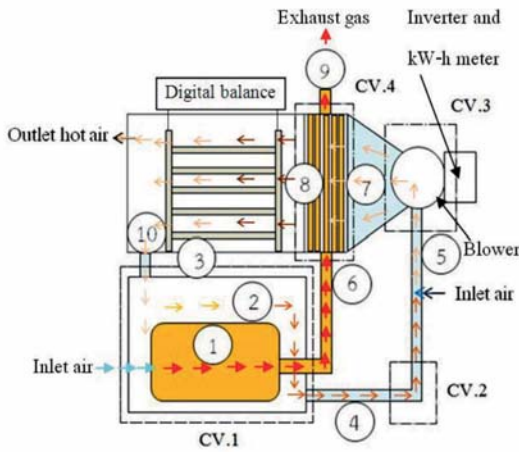

Fig. 4 Eucalyptus

2.3 Experimental procedure

The experiments were performed at different temperatures (60, 70 and 80 °C) and at a constant velocity 1.8 ms^{-1} [5] with a partially closed loop air system. 90% of the air was recycled in these

tests [7]. The slide valve of a 200 liter kiln was used to control the burning eucalyptus in the kiln allowing control of the air temperature in the drying chamber. The weight of the bananas was recorded every 0.5 hour with a digital balance ($\pm 0.01 \text{ kg}$). A temperature recorder (BTM-4208SD) was used to measure several temperatures in the dryer, such as the kiln temperature (1), outside kiln surface temperature (2), outlet temperature of the insulated wall (3), outlet temperature of the heat exchanger on the kiln surface (4), inlet blower temperature (5), inlet exhaust temperature (6), outlet blower temperature (7), inlet drying chamber temperature (8), outlet exhaust temperature (9), inlet temperature of the heat exchanger on the kiln surface (10) and ambient temperature (T_{amb}) as shown in **Fig. 5**. Relative humidity at the two inlet heat exchangers and the relative humidity of the ambient air were measured using a digital hygrometers series 485. An anemometer (Velocicalc plus model 8385-M-GB) was used to measure the air velocity. The energy consumed by the blower motor was recorded in kW-h meter. All experiments were carried out in duplicate.



(CV. is control volume)

Fig. 5 Diagram of the dryer air circulation system

2.4 Analysis methods

The pattern of the heating rate at the heat exchanger was calculated and the drying performance was dependent on a specific drying rate and a specific amount of energy consumption.

2.4.1 Heating rate of heat exchanger

The fluid flows of processing dried banana are dry air and vapor. The heating rate can be calculated as shown below:

$$Q_h = m_a ((C_{a2}T_2 + WC_vT_2) - (C_{a1}T_1 + WC_vt_1)) \quad (1)$$

when

- Q_h = heat transferred to the air (kW)
- m_a = mass flow rate of dry air (kgs⁻¹)
- C_{a1} = specific heat capacity of dry air of inlet heat exchanger (kJ kg⁻¹°C⁻¹)
- C_{a2} = specific heat capacity of dry air of outlet heat exchanger (kJ kg⁻¹°C⁻¹)

- W = humidity ratio (kg_{water} kg_{dry air}⁻¹)
- C_v = specific heat capacity of vapor (kJ kg⁻¹°C⁻¹)
- T_1 = temperature at inlet of dry air at heat exchanger (°C)
- T_2 = temperature at outlet of dry air at heat exchanger (°C)

$$ma = \rho Av \quad (2)$$

when

- ρ = density of dry air (kg/m³)
- A = cross section area (m²)
- v = velocity of dry air (ms⁻¹)

The C_a will change with temperature (T) as shown in equation (3) [8] and C_v is 1.88 kJ/kg °C [9].

$$C_a = 0.000000000377T^3 + 0.00000025095T^2 + 0.00003542694T + 1.003726 \quad (3)$$

2.4.2 Specific drying rate

Specific drying rate (SDR) can be defined as:

$$SDR = \frac{\text{evaporative water from product}}{DT \times m_a} \quad (4)$$

when

- DT = drying time (h)
- m_a = dry bone mass of product (kg_{solid})

2.4.3 Specific energy consumption

Specific energy consumption (SEC) can be defined as:

$$SEC = \frac{(2.6Q_b(3.6))}{\text{water evaporated from product}} \quad (5)$$

when

$2.6 =$ an electrical factor for converting to primary energy [10]

$Q_b =$ energy consumed by the blower motor (kWh)

$3.6 =$ constant for converting kWh to MJ

3. Results and Discussions

The heating rate behavior, the behavior of the specific drying rate and the behavior of the specific energy consumption are presented.

3.1 The heating rate behavior

Fig. 6 shows the heating rate of the kiln surface exchanger and **Fig. 7** shows the heating rate of the exhaust gas heat exchanger at a drying temperature of 70 °C. For a period of 0-5 hours, the moisture content in eucalyptus was evaporated by heating from burning wood in the kiln. The heating rates of the kiln surface exchanger and exhaust gas heat exchanger were increased and were beginning to stabilize because charcoal production was taking place and the drying temperature was being manually controlled via the air valve. The heating rate of the exhaust gas heat exchanger increased with drying time because the eucalyptus in kiln began burning and the temperature of the exhaust increased. After 5 hours, the

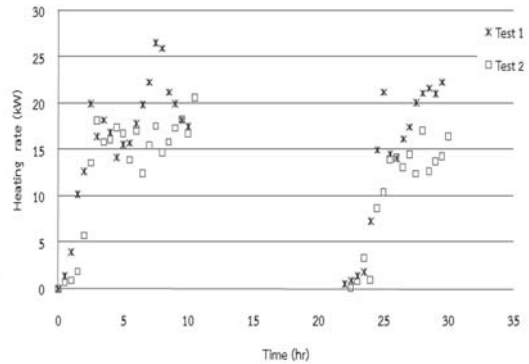

Fig. 6 Heating rate of kiln surface related to time at drying temperature 70 °C with air velocity 1.8 ms⁻¹

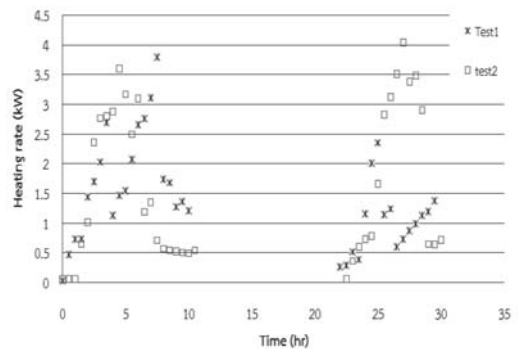

Fig. 7 Heating rate of exhaust gas heat exchanger related to time at drying temperature 70 °C with air velocity 1.8 ms⁻¹

heating rate of exhaust gas heat exchanger decreased, air valve was closed. The average heating rate of the kiln surface heat exchanger before flat banana had 14.48±6.84 kW and the drying time before flat banana was 10.25±0.25 hours. The average heating rate of the exhaust gas heat exchanger was 1.54±1.08 kW. After

drying the bananas (approximately 12 hours) the process was repeated using new eucalyptus. The heating rate behavior of heat exchanger found that drying flattened bananas took less time than drying bananas that were flattened after the drying process. The drying temperatures of 60 and 80 °C had the result tendency same the temperature 70 °C but heating rate of heat exchanger increased with increasing the drying temperature as shown in **Table 1**.

3.2 The behavior of specific drying rate

Fig. 8, the experimental results for the three temperatures showed that the specific drying rate increased from 0-5 hours and after 5 hours the specific drying rate decreased. This resulted in a peak specific drying rate of 5 hours because the air temperature increased with drying time and the water with in the bananas was easy to evaporate. After 5 hours, the bananas did not have the water near surfaceso the water inside banana was difficult to diffuse. When drying bananas, at three temperatures, after flattening, the specific drying rate

was lower than drying prior to flattening the bananas. This is because the banana had a fluid honey-like coating that stopped the water inside banana from freely evaporating.

3.3 The behavior of specific energy consumption

Electric energy which was not waste heat was record and analyzed. The energy from the eucalyptus was not recorded. **Fig. 9**, the experimental results of three temperatures before flattening the bananas showed that the specific energy consumption increased over a period of 0-2 hours and after 2 hours the specific energy consumption decreased. The result was related to water removal from the bananas. The experimental results of three temperatures after flat banana found that the specific energy consumption increased over a period of 0-2 hours between 5 to 7 MJ $\text{kg}_{\text{water}}^{-1}$ and after 2 hours the specific energy consumption decreased with drying time because the water inside bananas was difficult to evaporate while the energy consumption rates of electric energy was constant.

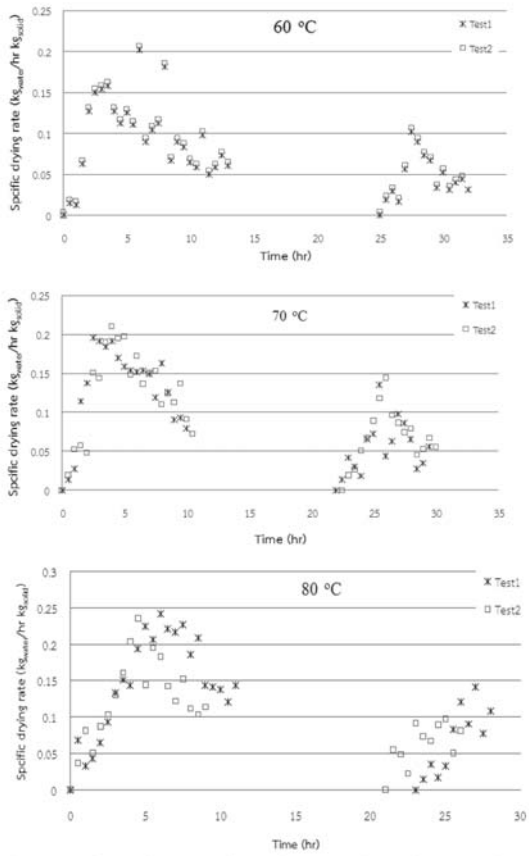

Fig. 8 Specific drying rates of drying temperatures 60, 70, 80 °C with air velocity 1.8 ms⁻¹ related to time

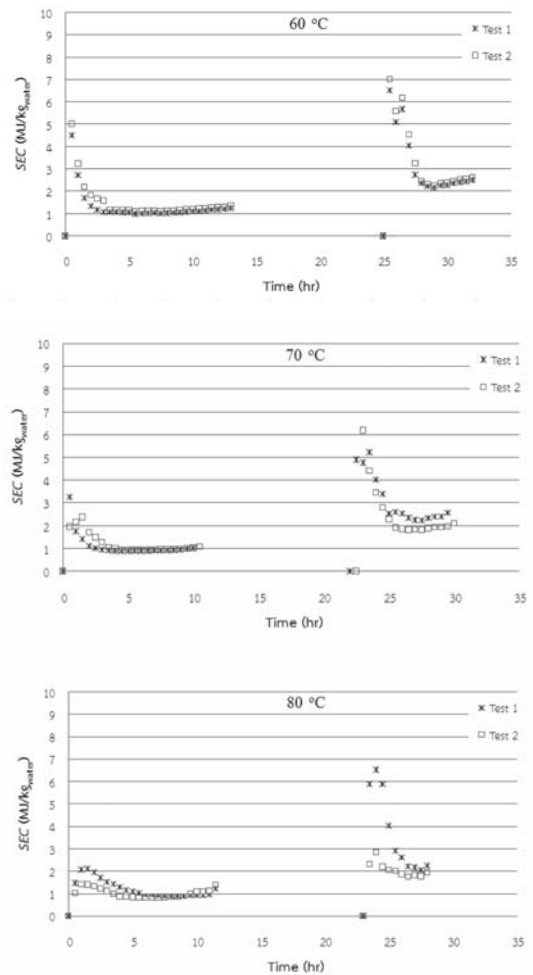

Fig. 9 Specific energy consumptions of drying temperatures 60, 70, 80 °C with air velocity 1.8 ms⁻¹ related to time

Table 1, at a constant velocity of 1.8ms^{-1} and at various air temperatures the bananas had an initial moisture content of about $241\pm 31.50\%$ dry basis and were dried until to final moisture content was about $48.47\pm 10.46\%$ dry basis. The heating rate of the exhaust gas heat exchanger, the heating rate of kiln surface heat exchanger and the specific drying rate, before flattening the banana, increased with an increase

in the air temperature. Increasing air temperature affected an increase in the water vapor pressure inside the banana and thus resulted in higher mass transfer coefficients. The inlet air valve of a 200 liter kiln was opened in relation to the set drying temperature. To increase the air temperature, the inlet air valve opening was increased and the eucalyptus burns more in the kiln.

Table 1 The calculation values of the experimental results for dried banana at a constant velocity of 1.8ms^{-1}

Description	60 °C	70 °C	80 °C
Heating rate of exhaust heat exchanger before flat banana (kW)	0.71 ± 0.40	1.54 ± 1.08	1.69 ± 1.35
Heating rate of kiln surface heat exchanger before flat banana (kW)	13.82 ± 6.63	14.48 ± 6.84	15.55 ± 9.03
Specific energy consumption, SEC ($\text{MJ kg}_{\text{water}}^{-1}$)	1.42 ± 0.055	1.21 ± 0.035	1.04 ± 0.074
Specific drying rate, SDR ($\text{kg}_{\text{water}}\text{h}^{-1}\text{kg}_{\text{solid}}^{-1}$)	0.085 ± 0.0004	0.114 ± 0.0009	0.127 ± 0.010
Eucalyptus (kg)	88 ± 4.2	85 ± 1.41	87.5 ± 2.12
Charcoal (kg)	38 ± 2.21	35.5 ± 9.19	36.5 ± 3.53
Final weight of product (kg)	13.54 ± 0.09	12.79 ± 0.16	13.13 ± 0.38
Min (%dry basis)	212.37 ± 10.41	255.31 ± 7.49	241.48 ± 51.80
Final moisture content (% dry basis)	40.98 ± 6.31	51.56 ± 5.12	49.12 ± 18.32
Drying time before flat banana (h)	13 ± 0.5	10.25 ± 0.25	10 ± 2
Total drying time (h)	20 ± 0.5	17.75 ± 0.35	15 ± 1.41
Color of dried bananas	good	good	Some bananas were burned

The amount of eucalyptus used to increase with increasing drying time using between 85 to 88 kg of eucalyptus. The specific energy consumption and total drying time decreased with increasing air temperature. The optimal condition in this study was found to be at $70\text{ }^{\circ}\text{C}$ which was considered from color

quality of the bananas in the first. It had good color. Next, the specific energy consumption at $70\text{ }^{\circ}\text{C}$ was lower than at $60\text{ }^{\circ}\text{C}$ and the specific drying rate at $70\text{ }^{\circ}\text{C}$ was higher than at $60\text{ }^{\circ}\text{C}$. The charcoal results of three temperatures were between 35-38 kg.

4. Conclusions

This research developed a 200 liter kiln for waste heat recovery to increase the performance of the heat exchanger, and investigated the optimal drying conditions for drying 30 kg of peeled bananas.

The biomass selected to generate heat was eucalyptus.

Firstly, decreasing heat loss within the structure of the drying chamber was developed by modifying the top of a 200 liter kiln. Secondly, the exhaust gas heat exchanger was modified using a group of copper tubes to increase the heat transfer to the air. Finally, different temperatures of 60, 70 and 80 °C at a constant velocity 1.8ms^{-1} were investigated and were carried out in duplicate. The bananas had an initial moisture content of $241.19\pm 31.50\%$ dry basis and were dried until to final moisture content of $48.47\pm 10.46\%$ dry basis. Before flattening the bananas, temperatures of 60, 70 and 80 °C had heating rates at exhaust gas heat exchanger of 0.71 ± 0.40 , 1.54 ± 1.08 and 1.69 ± 1.35 kW and had heating rates at kiln surface heat exchanger of 13.82 ± 6.3 , 14.48 ± 6.84 and 15.55 ± 9.03 kW, respectively. These results had greater heating rates than a previous dryer made of a 200 liter kiln waste heat recovery [5]. At temperatures of 60, 70 and 80 °C, the specific drying rates and the specific energy consumptions increased with increasing temperature. The three temperatures could produce

about 35-38 kg of charcoal. Some of the dried bananas from 80 °C were burned but at 60 and 70 °C they were not. A temperature of 70 °C was the optimal condition in this experiment. It produced good color, a high specific drying rate and a low specific energy consumption.

5. Acknowledgments

The authors express their sincere appreciation to Rajamangala University of Technology Lanna (Thailand) for financially supporting this study.

6. References

- [1] M. Aktas, S. Sevik and B. Aktekel, "Development of heat pump and infrared-convective dryer and performance analysis for stale bread drying," *Energy Conversion and Management*, vol. 113, pp. 82–94, 2016.
- [2] S. Janjai, N. Lamlert, P. Intawee, B. Mahayothee, B.K. Bala, M. Nagle and J. Mu"ller, "Experimental and simulated performance of a PV-ventilated solar greenhouse dryer for drying of peeled longan and banana," *Solar Energy*, vol. 83, pp. 1550–1565, 2009.
- [3] R. Smitabhindu, S. Janjai and V. Chankong, "Optimization of a solar-assisted drying system for drying bananas," *Renewable Energy*, vol. 33, pp. 1523–1531, 2008.
- [4] P. Chunkaew, "Technology transfer on construction and charcoal

- burning technique from 200 liter charcoal kiln,” *RMUTP research journal*, vol.4, no.1, pp. 129-140, 2010.
- [5] P. Chunkaew, A. Khadwilard and Ch.Thawongmyingsakul, “Drying bananas with a modified hot air dryer using waste heat from a 200 liter kiln,” *RMUTI journal*, vol.10, no.3, pp. 1-12, 2017.
- [6] P. Chunkaew, A. Tevata, P.Chorbamrung and A. Khadwilard, “Moisture content reduction dimension and color change of dried bananas in parabola dome,” in *Proceedings of research and creative innovations CRCI 3rd Conference*, Rajamangala University of Technology Lanna, Chiang Mai, Thailand, 2016, pp. 949-955.
- [7] A. Khadwilard and P. Chunkaew, “Modified hot air dryer by leaf stove for banana drying,” *Energy Procedia*, vol. 9, pp. 344-350, 2011.
- [8] S. Achariyaviriya, J.C. Moran and P. Chunkaew, “Dried sunflower seeds utilizing technique of pulsed fluidized bed,” in *Proceedings of ACEAT-145*, Osaka, Japan, 2014, pp. 661-670.
- [9] B. K. Bala, “Drying and storage of cereal grains,” *Science Publisher, Inc.* New Hampshire, 1997.
- [10] A. Achariyaviriya, “Simulation and optimization of the drying strategy for longan drying,” Doctor of Engineering Energy Technology Program School of Energy and Materials. King Mongkut’s University of Technology Thonburi, 2001.